

# **DRAUGHTSMAN CIVIL THEORY**

## **VOCATIONAL EDUCATION Higher Secondary - Second Year**

A Publication under  
Government of Tamilnadu  
Distribution of Free Textbook Programme  
(NOT FOR SALE)

Untouchability is a sin  
Untouchability is a crime  
Untouchability is inhuman

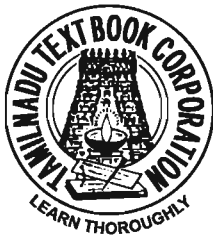

**TAMILNADU  
TEXTBOOK CORPORATION  
COLLEGE ROAD, CHENNAI-600 006.**

© Government of Tamilnadu  
First Edition - 2011

**CHAIRPERSON**

**Dr. P. PERUMAL**

Professor and Head  
Department of Civil Engineering  
Government College of Engineering  
Salem - 636 011.

**AUTHORS**

**Prof. V. RAJKUMAR**

Associate Professor  
Department of Civil Engineering  
Government College of Engineering  
Salem - 636 011

**Prof. M. ANBARASU**

Assistant Professor  
Department of Civil Engineering  
Government College of Engineering  
Salem - 636 011

**Mr. R. RAVI**

Vocational Teacher  
SenguntharMahajana Hr. Sec. School  
Tharamangalam - 636502  
Salem Dist

**Mr. V.V. BALAJI**

Vocational Teacher  
Government Hr. Sec. School  
Mettur Dam - 636 401  
Salem Dist

This book has been prepared by the Directorate of School Education  
on behalf of the Government of Tamilnadu

This book has been printed on 60 G.S.M Paper

**Printed by Wed Offset at :**

# SYLLABUS

## UNIT - I

### BUILDING CONSTRUCTION

- 1.1 ROOF : INTRODUCTION - REQUIREMENTS OF A GOOD ROOF  
CLASSIFICATION OF ROOFS - SLOPING / PITCHED ROOF - TECHNICAL  
TERMS USED IN PITCHED ROOF - TYPES OF PITCHED ROOF - TYPES OF  
SINGLE ROOF - DOUBLE ROOF OR PURLIN ROOF - TRUSSED ROOF - FLAT  
ROOF - ADVANTAGES AND DISADVANTAGES OF FLAT ROOF.
- 1.2 ROOFING MATERIALS : ROOF COVERING MATERIALS - POINTS TO BE  
CONSIDERED DURING THE SELECTION OF ROOFING MATERIALS - TYPES  
OF COVERING SHEETS FOR PITCHED ROOF - MODERN ROOFING SHEETS.
- 1.3 PAINTS AND VARNISHES : INGREDIENTS OF PAINT - CHARACTERISTICS  
AND USES OF PAINTS - TYPES OF PAINTS - COMPARISON BETWEEN  
ENAMEL PAINT AND CEMENT PAINT - METHOD OF PAINTING OLD AND  
NEW WOOD WORK - METHOD OF PAINTING OLD AND NEW IRON AND  
STEEL WORKS - PROCEDURE OF CEMENT PAINTING ON WALL SURFACE -  
IMPORTANT POINTS TO BE CONSIDERED WHILE PAINTING - DEFECTS IN  
PAINTING, CAUSES AND PRECAUTIONS – VARNISHES - INGREDIENTS OF  
VARNISHES - TYPES OF VARNISH - PROPERTIES OF VARNISH - USES OF  
VARNISHES - VARNISHING ON WOOD WORK.
- 1.4 ADMIXTURES IN CEMENT : TYPES OF ADMIXTURES IN CEMENT.
- 1.5 PLASTER OF PARIS : USES OF PLASTER OF PARIS
- 1.6 ACOUSTICS : ACOUSTICAL INSULATION MATERIALS.
- 1.7 PLASTICS : USES OF PLASTICS - TYPES OF PLASTICS.
- 1.8 PVC : ADVANTAGES OF PVC DOORS AND WINDOWS - DISADVANTAGES OF  
PVC DOORS AND WINDOWS - ADVANTAGES OF PVC PIPES -  
DISADVANTAGES OF PVC PIPES.
- 1.9 MODERN CONSTRUCTION MATERIALS : CERAMICS – GLASS -  
ELECTRICAL INSULATING MATERIALS - FLY ASH – GYPSUM – RUBBER -  
COMPOSITE MATERIALS.

## **UNIT - II**

### **PLANNING OF HOUSE**

- 2.1 INTRODUCTION : IMPORTANCE OF HOUSE – ORIENTATION.
- 2.2 SITE SELECTION : FACTORS TO BE CONSIDERED DURING SITE SELECTION  
- PRINCIPLES OF ORGANIZING A HOUSE.
- 2.3 HOUSE PLAN : ROOMS IN A HOUSE .
- 2.4 HOUSING : HOUSING DEMAND - TYPES OF RESIDENTIAL HOUSES.

## **UNIT - III**

### **WATER SUPPLY ENGINEERING**

- 3.1 INTRODUCTION : NEED FOR PROTECTED WATER SUPPLY - OBJECTIVES OF PUBLIC WATER SUPPLY SCHEME - PLANNING OF WATER SUPPLY SCHEME - WATER DEMAND - TYPES OF DEMANDS - PER CAPITA DEMAND - FACTORS AFFECTING THE PER CAPITA DEMAND .
- 3.2 SOURCES OF WATER : SURFACE SOURCES - SUBSURFACE SOURCES.
- 3.3 QUALITY OF WATER : IMPURITIES IN WATER AND ITS CLASSIFICATION - WATER QUALITY ANALYSIS .
- 3.4 TREATMENT OF WATER : A LAYOUT OF WATER TREATMENT PLANT – SCREENING – SEDIMENTATION - THEORY OF SEDIMENTATION - TYPES OF SEDIMENTATION - CLASSIFICATION OF SEDIMENTATION TANKS – FILTRATION - THEORY OF FILTRATION - TYPES OF FILTERS .
- 3.5 DISINFECTION OF WATER : NECESSITY OF DISINFECTION - METHODS OF DISINFECTION - SOME EASY METHODS OF DISINFECTION OF WATER - CHLORINATION.
- 3.6 WATER SOFTENING : PURPOSE OF WATER SOFTENING - HARDNESS OF WATER.
- 3.7 DISTRIBUTION SYSTEM OF WATER : REQUIREMENTS OF GOOD DISTRIBUTION SYSTEM - DIFFERENT SYSTEMS OF SUPPLYING WATER .

## **UNIT-IV**

### **SANITARY ENGINEERING**

- 4.1 INTRODUCTION : PURPOSE OF SANITATION - DEFINITION OF TERMS - COLLECTION AND CONVEYANCE OF REFUSE - SYSTEMS OF SEWERAGE - QUANTITY OF SEWAGE - CONSTRUCTION OF SEWERS - SEWER APPURTENANCES.
- 4.2 QUALITY OF SEWAGE : PROPERTIES OF SEWAGE.
- 4.3 TREATMENT OF SEWAGE : FLOW DIAGRAM OF SEWAGE TREATMENT SYSTEM.
- 4.4 SEPTIC TANKS : PRINCIPLE AND WORKING OF A SEPTIC TANK - CONSTRUCTION DETAILS OF SEPTIC TANK - OPERATION AND MAINTENANCE - SOAK PIT.
- 4.5 SLUDGE DISPOSAL : SLUDGE - QUANTITY OF SLUDGE - METHODS OF SLUDGE DISPOSAL.
- 4.6 POLLUTION CONTROL : WATER POLLUTION - TYPES OF WATER POLLUTION - EFFECTS OF WATER POLLUTION - PREVENTIVE MEASURES TO CONTROL WATER POLLUTION.
- 4.7 AIR POLLUTION : SOURCES OF AIR POLLUTION - EFFECTS OF AIR POLLUTION ON HUMAN BEINGS - EFFECTS ON ANIMALS - EFFECTS ON PLANTS (VEGETATION) - EFFECTS ON MATERIALS - EFFECT ON TEMPERATURE - EFFECTS ON ECONOMIC CONDITIONS - PREVENTION AND CONTROL OF AIR POLLUTION.

## **UNIT-V**

### **AESTHETICS OF A HOUSE**

- 5.1 INTRODUCTION : IMPORTANCE OF GOOD TASTE - ELEMENTS OF ART - REQUIREMENTS OF A GOOD STRUCTURAL DESIGN - REQUIREMENTS OF A GOOD DECORATIVE DESIGN - PRINCIPLES OF DESIGN - COLOUR AND COLOUR BLENDING - CHARACTERISTICS OF COLOURS - PRANG COLOUR WHEEL - COLOUR HARMONIES - SELECTION OF COLOURS FOR HOME - GENERAL - HOME FURNISHING AND DECORATION - POINTS TO BE CONSIDERED WHILE SELECTING FURNITURES - ARRANGEMENT OF FURNITURES - FURNITURES IN VARIOUS ROOMS.

## **UNIT - VI**

### **SURVEYING**

- 6.1 INTRODUCTION : DEFINITION – OBJECTIVE - USES OF SURVEYING - PRIMARY DIVISIONS OF SURVEYING - CLASSIFICATION OF SURVEYING.
- 6.2 CHAIN SURVEYING : DEFINITION - OBJECTIVES OF CHAIN SURVEYING - INSTRUMENTS FOR CHAIN SURVEYING – RANGING - OBSTACLES IN CHAINING - ERRORS IN CHAINING.
- 6.3 LEVELLING : DEFINITION - TECHNICAL TERMS - BENCH MARK AND ITS TYPES - REDUCED LEVEL - LEVELLING INSTRUMENTS - DIFFERENT TYPES OF LEVELS – SETTING UP THE INSTRUMENT - LEVELLING STAFF - REDUCTION OF LEVELS.

## **UNIT - VII**

### **HYDRAULICS AND HYDRAULIC MACHINERY**

- 7.1 HYDRAULICS : INTRODUCTION – FLUIDS - PROPERTIES OF FLUIDS - PRESSURE (P) - PRESSURE HEAD - HYDROSTATIC PRESSURE ON SURFACE - TOTAL PRESSURE - CENTRE OF PRESSURE - DEPTH OF CENTRE OF PRESSURE - THREE TYPES OF IMMERSED PLANE SURFACE AREA - FLOW THROUGH ORIFICE - CLASSIFICATION OF ORIFICE - VENA CONTRACTA - HYDRAULIC CO-EFFICIENTS - FLOW THROUGH AN ORIFICE .
- 7.2 FLOW THROUGH PIPES : PIPE - TYPES OF FLOW - CRITICAL VELOCITY - HYDRAULIC GRADIENT LINE - TOTAL ENERGY LINE - LOSS OF HEAD - WETTED PERIMETER(P) - HYDRAULIC MEAN DEPTH(M) - CHEZY'S FORMULA USED FOR THE DETERMINATION OF LOSS OF HEAD DUE TO FRICTION - DARCY'S FORMULA FOR FINDING LOSS OF HEAD DUE TO FRICTION - DARCY'S FORMULA FOR FINDING DISCHARGE.
- 7.3. FLOW THROUGH CHANNELS : AREA OF CHANNEL(A) - WETTED PERIMETER(P) - HYDRAULIC MEAN DEPTH(M) - DISCHARGE THROUGH CHANNELS USING CHEZY'S FORMULA - FORMULAE FOR FINDING AREA, WETTED PERIMETER AND HYDRAULIC MEAN DEPTH - MOST ECONOMICAL SECTION FOR CHANNELS.
- 7.4 HYDRAULIC MACHINERY : PUMPS - CLASSIFICATION OF PUMPS - TYPES OF PUMPS - AIR VESSELS - COMPARISON BETWEEN SINGLE ACTING AND DOUBLE ACTING RECIPROCATING PUMPS - CENTRIFUGAL PUMP - COMPARISON OF CENTRIFUGAL PUMP AND RECIPROCATING PUMP.

## **UNIT - VIII**

### **HIGHWAY ENGINEERING**

- 8.1 INTRODUCTION : DEFINITION - CHARACTERISTICS OF ROAD TRANSPORT - USES OF ROADS - HISTORY AND DEVELOPMENT OF ROADS IN INDIA - NAGPUR PLAN - CLASSIFICATION OF ROADS - CLASSIFICATION OF ROADS ACCORDING TO LOCATION AND FUNCTION - CLASSIFICATION BASED ON THE MATERIAL USED FOR ROAD CONSTRUCTION.
- 8.2. HIGHWAY GEOMETRIC DESIGN : ROAD STRUCTURE - CAMBER OR CROSS SLOPE OR CROSS FALL - IRC RECOMMENDATIONS FOR ROAD CAMBER - USES OF CAMBER - TYPES OF CAMBER - SUPER ELEVATION - ADVANTAGES OF SUPER ELEVATION - ROAD GRADIENT - FACTORS AFFECTING GRADIENT - TYPES OF GRADIENT - SIGHT DISTANCE - TYPES OF SIGHT DISTANCE.
- 8.3 MATERIALS FOR HIGHWAY CONSTRUCTION : TYPES OF ROAD AGGREGATES - REQUIREMENTS OF GOOD AGGREGATE - TESTS FOR AGGREGATES - TESTS FOR BITUMINOUS MATERIAL .
- 8.4 STABILISATION AND CONSTRUCTION OF ROADS : OBJECTS OF SOIL STABILIZATION - METHODS OF SOIL STABILIZATION - EARTH ROADS - CONSTRUCTION OF EARTH ROAD - MAINTENANCE OF EARTH ROAD - GRAVEL ROADS - METHODS OF CONSTRUCTION OF GRAVEL ROAD - CONSTRUCTION OF GRAVEL ROAD - CONSTRUCTION OF WATER BOUND MACADAM ROAD (W.B.M. ROAD) - DEFECTS OF WBM ROAD - CONSTRUCTION OF BITUMINOUS ROADS - CONCRETE ROADS - METHODS OF CONSTRUCTION OF CEMENT CONCRETE ROADS - CONSTRUCTION PROCEDURE FOR CEMENT CONCRETE ROADS - MERITS OF CONCRETE ROADS - DEMERITS OF CONCRETE ROADS.
- 8.5. ROAD SIGNALS : ROAD SIGNALS - SITUATIONS FOR INSTALLATION OF SIGNALS - TYPES OF SIGNALS.
- 8.6. ROAD SIGNS : PURPOSE OF ROAD SIGNS - TYPES OF ROAD SIGNS.
- 8.7. ROAD ACCIDENTS : CAUSES OF ROAD ACCIDENTS - EFFECTS OF ROAD ACCIDENTS - SAFETY MEASURES.
- 8.8. ROAD SIDE DEVELOPMENTS : USES OF ROAD SIDE ARBORICULTURE - SELECTION OF TREES FOR ROAD SIDE ARBORICULTURE.

## HYDRAULICS FORMULA

### DENSITY

$$\text{Density, } [\rho] = \frac{\text{Mass of fluid (M)}}{\text{Volume of fluid (V)}}$$

### SPECIFIC WEIGHT / WEIGHT DENSITY

$$w = W/V$$

$$\begin{aligned} \text{But, Weight} &= \text{Mass} \times \text{Acceleration due to gravity} \\ &= M \cdot g \end{aligned}$$

$$\text{Specific weight (w)} = \frac{W}{V}$$

### RELATIVE DENSITY / SPECIFIC GRAVITY

$$S \text{ (for liquids)} = \frac{\text{weight density of liquid}}{\text{weight density of water}}$$

$$S \text{ (for gases)} = \frac{\text{weight density of gas}}{\text{weight density of air}}$$

### SQUARE PLATE

$$\text{Area of plate (A)} = a^2$$

$$\text{Moment of inertia (I}_G) = \frac{a^4}{12}$$

$$\text{Total pressure (P)} = wA\bar{x}$$

$$\text{Depth of centre of pressure } (\bar{h}) = \frac{I_G}{A\bar{x}} + \bar{x}$$

### RECTANGULAR PLATE

$$\text{Area of the plate (A)} = b \times d$$

$$\text{Moment of inertia (I}_G) = \frac{bd^3}{12}$$

$$\text{Total pressure (P)} = wA\bar{x}$$

$$\text{Depth of centre of pressure } (\bar{h}) = \frac{I_G}{A\bar{x}} + \bar{x}$$



**CIRCULAR PLATE**

Area of the plate (A)  $= \frac{\pi}{4} d^2$

Moment of inertia ( $I_G$ )  $= \frac{\pi}{64} \times d^4$

Total pressure (P)  $= wA \bar{x}$

Depth of centre of pressure ( $\bar{h}$ )  $= \frac{I_G}{A\bar{x}} + \bar{x}$

**WETTED PERIMETER**  $P = \pi d$

**HYDRAULIC MEAN DEPTH (m)**

Hydraulic mean depth (m)  $= \frac{\text{Area of flow (A)}}{\text{wetted perimeter(P)}}$

$m = d / 4$

**CHEZY'S FORMULA USED FOR DETERMINATION OF LOSS OF HEAD DUE TO FRICTION**

Mean velocity of flow,  $V = C \sqrt{mi}$  we get

Also  $i = \frac{h_f}{l}$

loss of head due to friction  $h_f = \frac{v^2 l}{C^2 m}$

**DARCY'S FORMULA USING LOSS OF HEAD DUE TO FRICTION**  $h_f = \frac{flv^2}{2gd}$

**DARCY'S FORMULA FOR FINDING THE DISCHARGE**  $h_f = \frac{f l Q^2}{12d^5}$

**FORMULAE FOR FINDING AREA, WETTED PERIMETER AND HYDRAULIC MEAN DEPTH:**

Parameter	Rectangle	Trapezoidal
Area	$A = b \times d$	$A = (b + nd) d$
Wetted Perimeter	$P = b + 2d$	$P = b + 2d\sqrt{1+n^2}$
Hydraulic Mean depth	$m = \frac{A}{P} = \frac{bd}{b+2d}$	$m = \frac{A}{P} = \frac{(b+nd)d}{b+2d\sqrt{1+n^2}}$

Quantity of discharge  $Q = A \times V$

# **CONTENT**

	<b>PAGE NO.</b>
<b>1. BUILDING CONSTRUCTION</b>	<b>1</b>
<b>2. PLANNING OF HOUSE</b>	<b>27</b>
<b>3. WATER SUPPLY ENGINEERING</b>	<b>45</b>
<b>4. SANITARY ENGINEERING</b>	<b>67</b>
<b>5. AESTHETICS</b>	<b>90</b>
<b>6. SURVEYING</b>	<b>107</b>
<b>7. HYDRAULICS &amp; HYDRAULIC MACHINERY</b>	<b>134</b>
<b>8. HIGHWAY ENGINEERING</b>	<b>166</b>
<b>9. MODEL QUESTION PAPER</b>	<b>194</b>
<b>10. BLUE PRINT OF QUESTION PAPER</b>	<b>198</b>

# UNIT I

## BUILDING CONSTRUCTION

### 1.1 ROOF

#### 1.1.1 INTRODUCTION

A roof is the uppermost part of a building, provided as a structural covering, to protect the building from rain, sun, wind, etc. Roof protects the building from the damages starting from the top.

#### 1.1.2 REQUIREMENTS OF A GOOD ROOF

The following requirements are to be satisfied by a well planned roof :

- i) It should be durable against the adverse effects of wind, sun, rain etc.
- ii) It should give good insulation against heat and sound.
- iii) It should be structurally sound and stable.
- iv) It should permit good drainage.
- v) It should have good water-proofing arrangement.
- vi) It should be fire resistant.

#### 1.1.3 CLASSIFICATION OF ROOFS

- 1) Sloping / Pitched Roof
- 2) Flat Roof
- 3) Curved or Shell Roof

#### 1.1.4 SLOPING / PITCHED ROOF

Roofs with sloping surfaces are known as pitched roofs. These roofs are constructed out of wood, steel or combinations of both and the edges of their triangular portions are supported by walls. The slope of the roof depends upon the distance between the two supporting walls, type of roof covering material to be used as per the climatic conditions in that locality.

#### 1.1.5 TECHNICAL TERMS USED IN PITCHED ROOF

1. GABLE: The triangular upper part of a wall formed at the end of a pitched roof is known as a gable. Fig 1.1

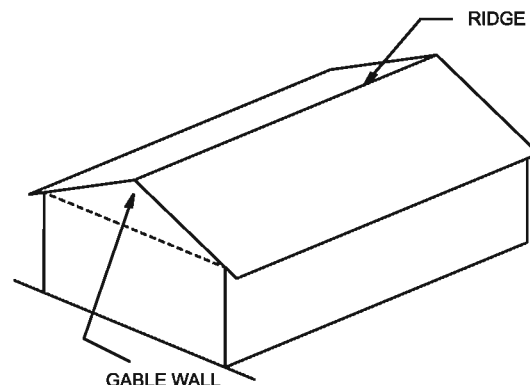
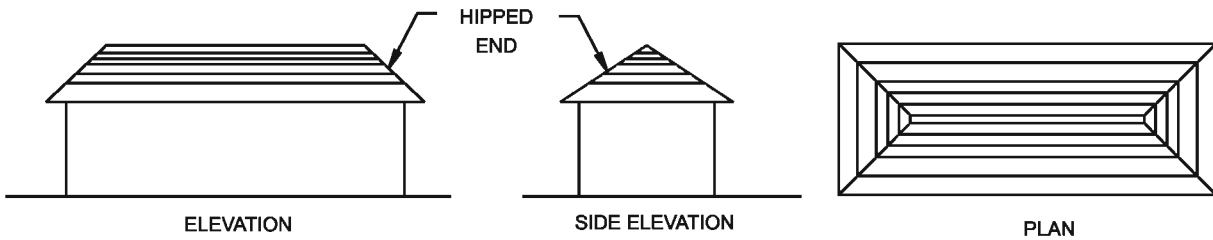

Fig. 1.1 GABLED ROOF

2. **HIP:** The external angle which is greater than  $180^\circ$  formed at the intersection of two roof slopes is known as hip. Fig 1.2



**Fig. 1.2 HIPPED ROOF**

3. **RIDGE:** It is the apex line of the sloping roof formed by the intersection of inclined surfaces of roof. Fig 1.1

4. **RISE:** It is the vertical height measured from the lowest to the highest point of a gable. Fig 1.3

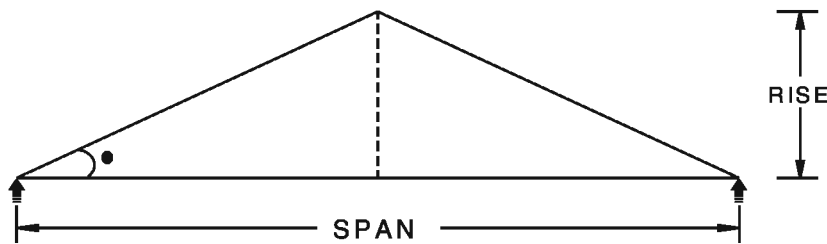
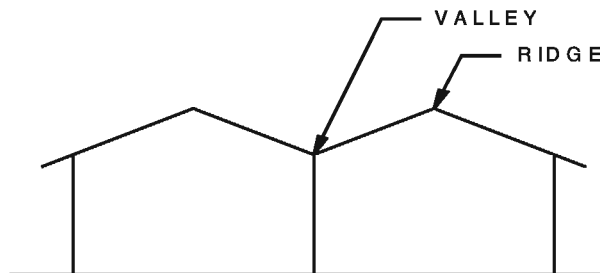

**Fig. 1.3. RISE**

5. **PITCH:** The inclination of the sides of a roof to the horizontal is known as pitch.

6. **EAVES:** Eaves of a roof are the bottom end of a pitched roof.

7. **VALLEY:** When two roof surfaces meet together and form an internal angle less than  $180^\circ$  it is known as valley. Fig 1.4



**Fig. 1.4. VALLEY**

8. **RAFTER:** These are the pieces of timber which extend from the eaves to the ridge.

9. **PURLIN:** The wooden or steel pieces which are placed horizontally to carry the common rafters are known as purlin.

10. **BATTENS:** These are thin strips of wood which are nailed to the rafters for laying roof materials.

11. **SPAN:** The horizontal distance between the internal faces of walls or supports is known as span.

### 1.1.6 TYPES OF PITCHED ROOF

- 1) Single roof
- 2) Double or Purlin roof
- 3) Trussed roof

### 1.1.7 TYPES OF SINGLE ROOF

- 1) Lean-to roof
- 2) Couple roof
- 3) Couple closed roof
- 4) Collar Beam roof

1. **LEAN-TO ROOF:** Lean to roof is used for verandahs and sheds attached to the main buildings. Its span is limited to 2.5 m. To obtain the required slope, the rafters which slope on one side are secured to wall plates at the upper end and wall plate or post plate at the lower end. The upper wall plate is supported on a corbel and the lower wall plate rests on wall or posts. Wooden battens are fixed onto the rafters to carry the roof covering materials. Fig 1.5

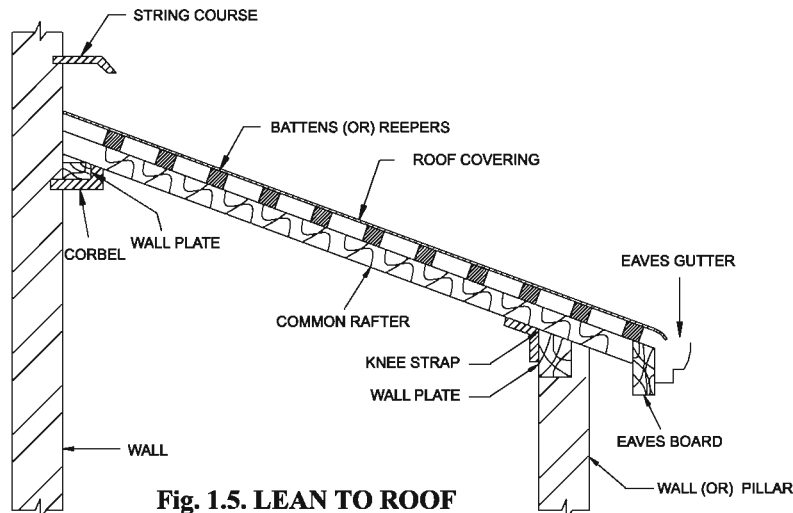

**Fig. 1.5. LEAN TO ROOF**

2. **COUPLE ROOF :** These roofs are formed by connecting the two inclined rafters. They are fixed to wall plates at the lower end. The roofing material is supported on battens, which are suitably spaced and fixed onto the rafters. This type is suitable for spans up to 3.6 m. Fig 1.6

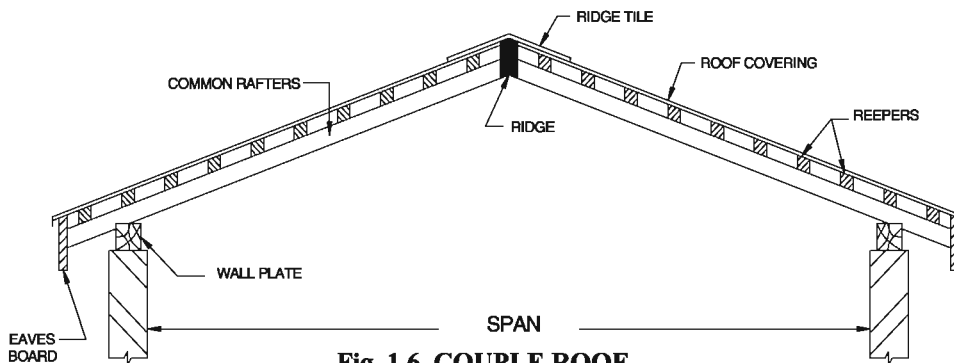

**Fig. 1.6. COUPLE ROOF**

3. **COUPLE CLOSED ROOF:** This is similar to the couple roof. When the span and intensity of loading are increased, the horizontal thrust developed is likely to push the rafter away. To prevent this tendency, the rafters are connected by horizontal members called tie at the bottom as shown in the fig 1.7. This tie member is used for fixing false ceiling at top. This type of roof is known as couple closed roof and can be used for span up to 4.2m. Fig 1.7

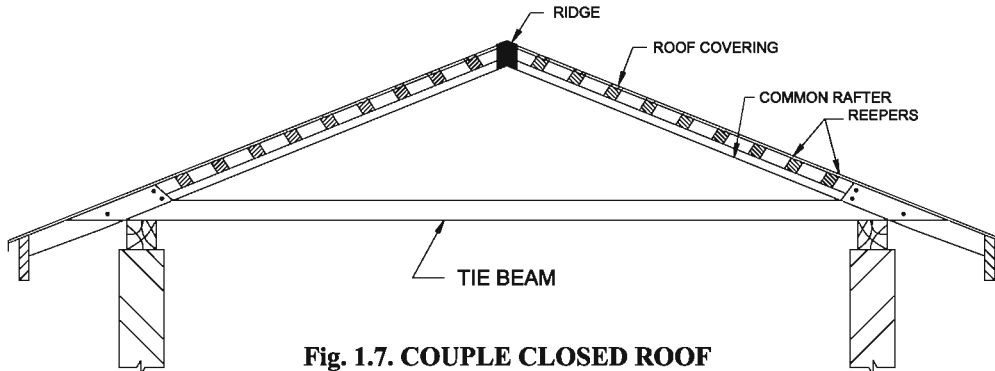

**Fig. 1.7. COUPLE CLOSED ROOF**

#### 4. COLLAR BEAM ROOF

Collar beam roof is similar to the couple close roof, except that the tie beam is fixed near the middle of the rafters instead of the bottom end. The tie beam in this case is called collar beam. This type of roof is suitable for a span up to 5.5 m. Fig 1.8

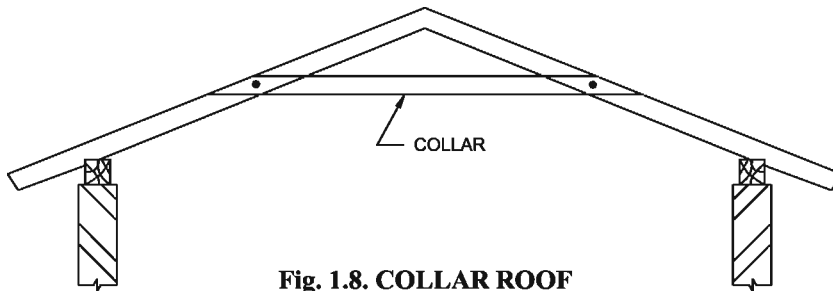

**Fig. 1.8. COLLAR ROOF**

#### 1.1.8 DOUBLE ROOF OR PURLIN ROOF

In this type, an additional member known as purlin is used to support the common rafter at intermediate points. If purlins are not used, then the size of the common rafter would be uneconomical. To economize the construction purlins are used so that rafters of smaller size can be used. This type of roof can be economically adopted upto span of 4.8m.

#### 1.1.9 TRUSSED ROOF

These types of roofs are constructed in triangular shape and made up of steel or timber. These are used when the span exceeds 5.5m. The spacing of trusses depends upon the load on the roof. The following are some important types of trussed roof.

- 1) King post truss
- 2) Queen post truss
- 3) Steel truss

1. **KING POST TRUSS:** King post truss is used for spans from 5m to 9m. In king post truss, the common rafters are supported by wooden frame work called truss at required intervals. The frame work consists of two principal rafters, tie beam, two struts and a king post. Purlins are placed longitudinally over the principal rafters to support the common rafters. The spacing of the king post truss is generally adopted as 3m. Fig 1.9

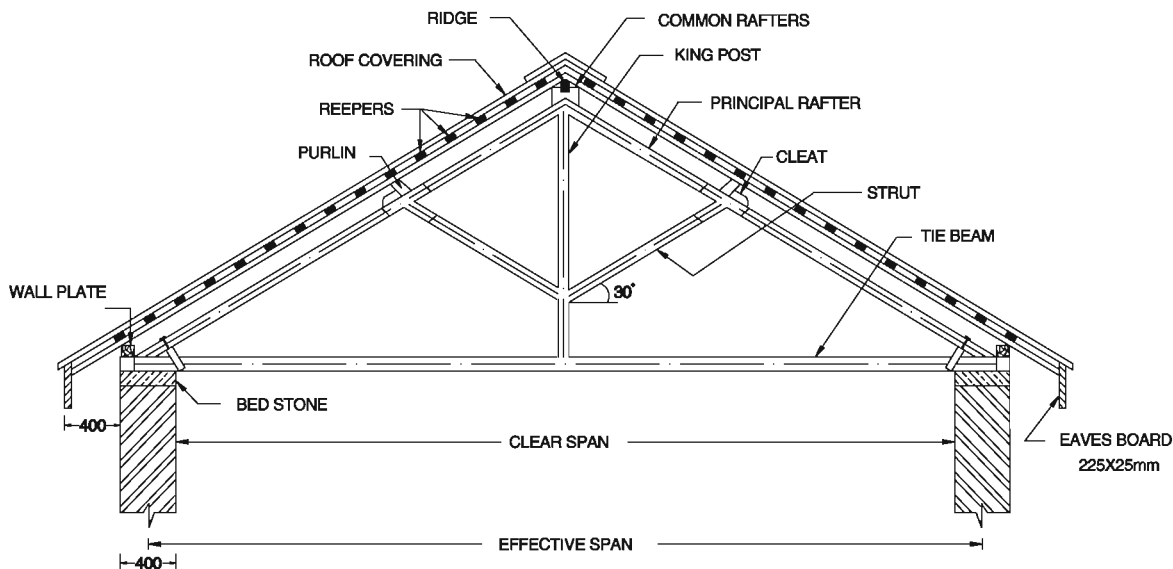

**Fig. 1.9. KING POST TRUSS**

2. **QUEEN POST TRUSS:** Queen post truss is used for spans from 9m to 14m. In queen post truss the frame work consists of two principal rafters, two queen posts, two struts, one straining beam, one straining sill and a tie beam. Common rafters are placed over the purlins which are placed over the principal rafters. Fig 1.10

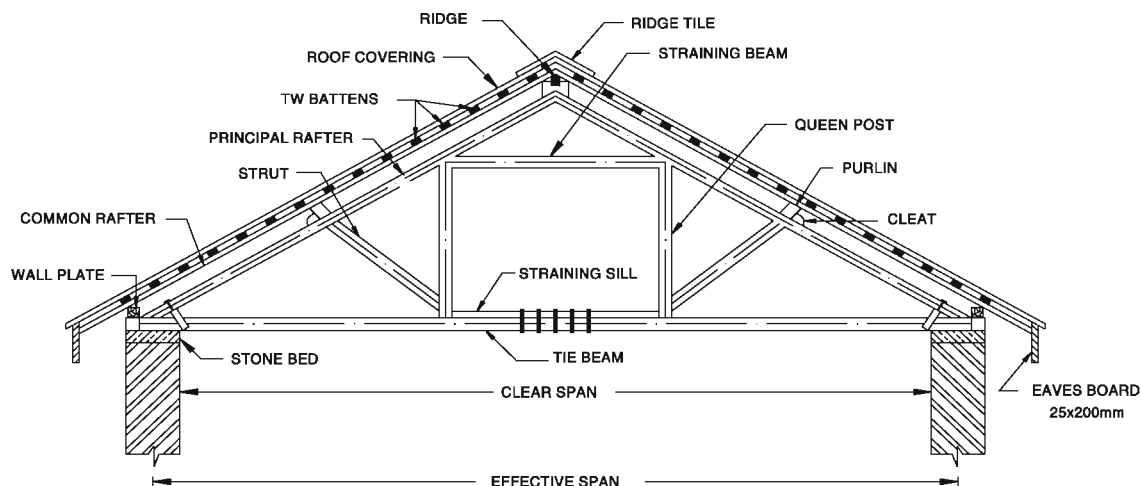

**Fig. 1.10. QUEEN POST TRUSS**

3. **STEEL TRUSS:** For spans greater than 12 m, steel trusses are economical. Mild steel rolled sections of standard shapes and sizes are available in the market. This facilitates the construction of steel trusses. For small spans, the steel roof trusses consist of angles, connected by rivets or welds. The designs of steel trusses become simple because steel can take both compression and tension. A few types of steel trusses are shown in Fig 1.11

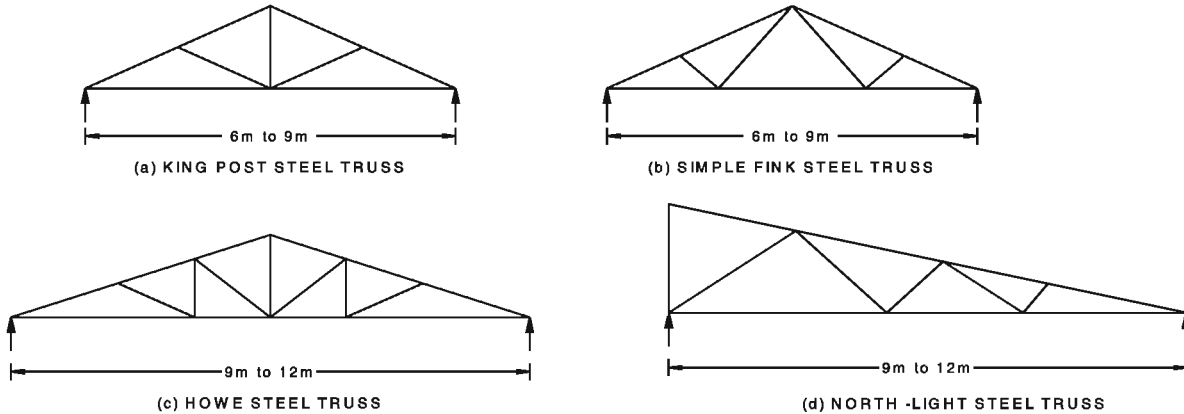

**Fig. 1.11. FEW STEEL TRUSSES**

**1.1.10 FLAT ROOF**

The roof which is nearly flat or at a slope upto  $10^0$  is known as flat roof.

- 1) R.C.C roof
- 2) Madras Terrace roof
- 3) Lime concrete roof
- 4) Bengal Terrace roof

**1. METHOD OF CONSTRUCTION OF REINFORCED CEMENT CONCRETE (RCC) ROOF SLAB**

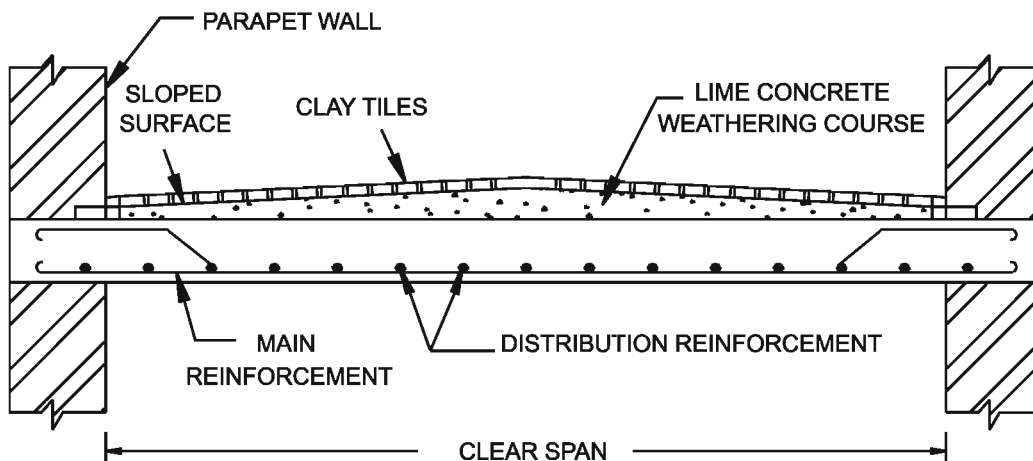

**Fig. 1.12. R.C.C ROOF**



i. **CENTERING:** Since the concrete is in a semisolid state during placing it becomes necessary to give support until it gains sufficient strength. Centering is a temporary platform which is formed by using wooden planks and props or steel plates and steel pipes. It should be strong enough to withstand the weight of the roof concrete. Before laying the steel rods the surface of centering should be applied with grease for easy removal of plank. The steel rods are then placed in position and are tied by using binding wires. Usually the concrete mix proportion of 1:1.5: 3 is placed over the centering and they are compacted by using vibrator.

ii. **CURING AND REMOVAL OF FORM WORK:** After laying of concrete the surface of concrete should be cured for about 21 to 28 days. Only then the concrete will attain its strength. The form work should be removed after 14 days.

iii. **WEATHERING COURSE:** The weathering course will protect the surface of the roof from weathering actions. The surki mortar of 1:1.5 (1 lime and 1.5 brick bats) ratio is laid on the roof surface for about 100 mm thick. Above this flat tiles are laid by using cement mortar 1:3. The joints inbetween the tiles are pointed by using cement mortar. Proper slope is maintained for easy drainage of rain water. Fig 1.12

## 2. MADRAS TERRACE ROOF

- i) Madras terrace roof was widely used in Madras Province.
- ii) It consists of teak wood joists placed over steel girders with a furring piece between them. The furring piece gives necessary slope to the flat roof.
- iii) A course of well burnt bricks is laid in lime mortar keeping the bricks on their edges diagonally across the joists.
- iv) A 10cm thick brick bat concrete is laid over it and thoroughly compacted by frequent wetting with water.
- v) Flat tiles are laid in 3 layers over this in lime mortar.
- vi) Finally three coats of plaster are applied for finishing the surface and a slope of about 1 in 30 is given for draining rain water. Fig 1.13

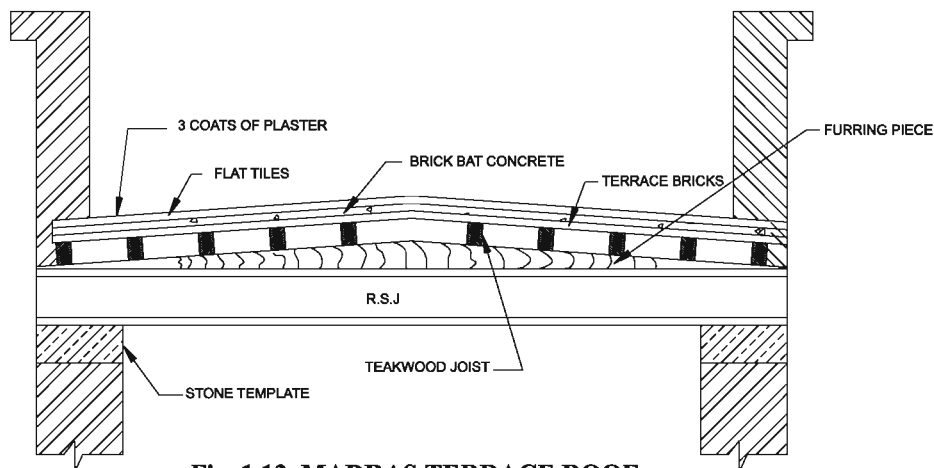

**Fig. 1.13. MADRAS TERRACE ROOF**

### **1.1.11 ADVANTAGES AND DISADVANTAGES OF FLAT ROOF**

#### **ADVANTAGES**

- 1) It is easy for construction and maintenance.
- 2) Upper floor can be easily constructed.
- 3) Flat roof possess good insulation properties.
- 4) It posses more fire resistance than a pitched roof.
- 5) A flat roof provides better light, ventilation and architectural appearance to the building.
- 6) False ceiling is not necessary for flat roof

#### **DISADVANTAGES**

- 1) Initial cost is higher than the pitched roof.
- 2) Flat roof is not suitable for long span, without the introduction of columns and beams.
- 3) Flat roof is not suitable for places of heavy snowfall.
- 4) Construction speed is slower than the pitched roof.

## **1.2 ROOFING MATERIALS**

### **1.2.1 ROOF COVERING MATERIALS**

- 1) Thatches
- 2) Wooden shingles
- 3) Tiles
- 4) A.C. sheets
- 5) G.I. sheets
- 6) Light weight roofing materials
- 7) Poly vinyl chloride sheets
- 8) Reinforced cement concrete
- 9) Galvalume sheets

### **1.2.2 POINTS TO BE CONSIDERED DURING THE SELECTION OF ROOFING MATERIALS**

- 1) Climate of the locality
- 2) Slope of the roof
- 3) Type of the building
- 4) Durability

- 5) Construction and maintenance cost of the building.
- 6) Resistance to fire and heat
- 7) Weight of the roofing materials
- 8) Appearance and beauty of materials

### 1.2.3 TYPES OF COVERING SHEETS FOR PITCHED ROOF

- 1) Asbestos cement sheets
- 2) Light roofing sheets
- 3) Galvanized iron sheets
- 4) Galvalume Sheets

#### 1. ASBESTOS CEMENT SHEETS

They are manufactured by mixing the cement with about 15 % of asbestos fibre. The paste so formed is pressed under rollers. These fibres are so soft like silk. The corrugations help to increase the strength and rigidity and they permit easy flow of rain water.

#### TYPES OF A.C SHEETS

- i) Trafford sheet
  - ii) Corrugated sheet
- i. **TRAFFORD SHEET:** Each trafford sheet consists of four deep corrugations alternating with flat portions. The thickness of these sheets is 6 mm. They are available with a breadth of 1.02 m and lengths of 2.5 m, 3 m, 3.5 m and 4 m. Fig 1.14

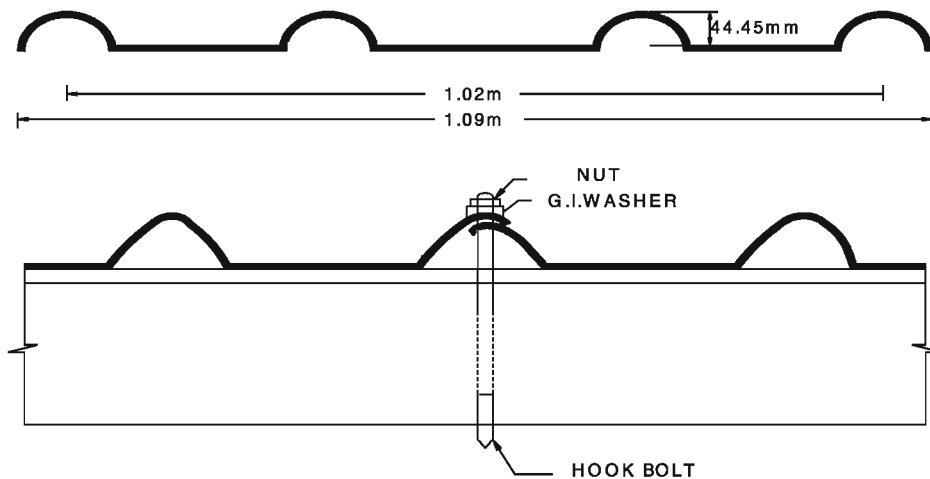

**Fig. 1.14. TRAFFORD SHEET**

ii. **CORRUGATED SHEET:** These sheets are prepared by pressing plates between rollers. These sheets are manufactured with series of parallel depression (corrugations) from one end to the other. These sheets are more resistant to fire. These sheets produce noise when rain water falls on them. Crank bolts and 'J' hooks are used to fix these sheets with the purlins. To avoid the leakage of water bituminous washers are used. There are 7.5 corrugations in this sheet. The upper and lower corrugations are equal. The thickness of these sheets is 6 mm. They are available with a breadth of 1.05 m and lengths of 2.5 m, 3 m, 3.5 m and 4 m. Fig 1.15

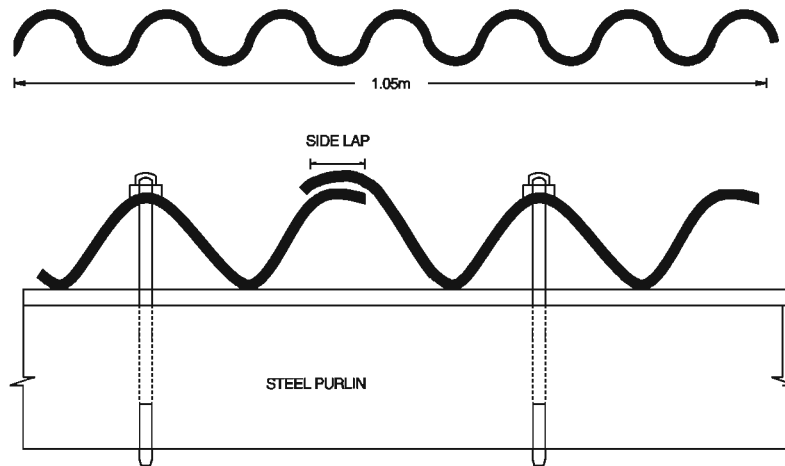

**Fig. 1.15. CORRUGATED SHEET**

#### USES OF A.C. SHEET

- i) A.C. sheets are fairly cheap and not easily affected by fire.
- ii) They need not be painted.
- iii) It is not affected by insects.
- iv) It is used in industries, large buildings and workshops.

#### CHARACTERISTICS OF A.C. SHEET

- i) Asbestos cement sheet can be sawn, nailed or punched.
- ii) They are sound proof.
- iii) They are not affected by acids and alkalis.
- iv) They are not good conductor of heat.
- v) Less maintenance cost.
- vi) They are used for decorative purposes.

#### A.C. RIDGE PIECE COVER

To avoid water entering into the roof the cover pieces laid at the top junction of the two sloped A.C. sheets are known as A.C. ridge covers.

## 2. LIGHT ROOFING SHEETS

These roof coverings are manufactured by inserting tar felt inbetween the two asbestos clothes with corrugations. The thickness of these sheets is 3 mm. They are available in a breadth of 1 m and lengths of 2 m, 2.5 m and 3 m. They are painted with aluminium paint on both sides. They are easily bendable. They are easy to be cut and nailed. These sheets are cheap in cost but has less strength. This type of roof covering is suitable for cattle sheds and nutrition centres.

### TYPES OF LIGHT ROOFING SHEETS

- 1) Tar sheet
- 2) Plastic sheet
- 3) Poly vinyl chloride sheet

## 3. GALVANIZED IRON SHEETS

These sheets are prepared by pressing wrought iron plates between rollers. They are galvanized with a zinc coat to avoid rusting due to climatic change. They are strong due to corrugations. They are also manufactured as plain sheets.

### ADVANTAGES OF GALVANISED IRON SHEET

- i) They need not be painted, so cost reduces.
- ii) As it is less in weight handling is easier.
- iii) Low conductor of heat.
- iv) Not easily corrodible.

### DIFFERENCES BETWEEN A.C. SHEET AND GALVANIZED IRON SHEET

Sl.No	Asbestos Cement Sheet	Galvanized iron sheet
1	Breakable and requires much care in handling	Not breakable and can be handled with little care.
2	Thickness is more than GI sheet	Thickness of sheet is less
3	Less initial cost	High initial cost
4	Less resistance to fire	High resistance to fire
5	Heavy in weight	Light in weight
6	Makes little noise when something falls over them	Makes more noise when something falls over them
7	Maintenance cost not required	Requires maintenance cost
8	Not affected by acids	Affected by acids
9	Good conductor of heat	Low conductor of heat
10	It is manufactured using cement and asbestos fibers	It is manufactured from wrought iron plates
11	Sound proof	Not sound proof
12	Painting is not required	Painting is required

## **1.2.4 MODERN ROOFING SHEETS**

1. **CORRUGATED ALUMINIUM SHEETS:** Aluminium is a light weight metal and does not corrode like steel. The thickness of corrugated aluminium sheets vary from 0.5 to 0.8mm. They require no maintenance and has also a good resale value. The only disadvantage is that they are more expensive.

2. **PVC ROOFING SHEETS:** Rigid PVC corrugated sheets are transparent with a light transmission of not less than 70 to 80 percent. Since these sheets do not perform well with direct exposure to sunlight and are also not fire proof, they are mainly used in temporary constructions, car parks etc. where a very light roofing of pleasing appearance is required.

3. **GLASS FIBRE REINFORCED PLASTIC SHEETS:** Corrugated glass fibre reinforced plastic sheets with different profiles and light transmissions are used as light roofing materials. Unlike GI and aluminium sheets, these sheets have little resale value.

4. **BITUMINOUS SHEETS:** Light roofing made of bitumen and paper pulp is generally used for covering of temporary sheds. They are cheap but their life is very short (3 to 5 years). They do not have resale value.

5. **RED MUD CORRUGATED ROOFING SHEETS:** Red mud is obtained from waste materials derived in aluminium industry. It is combined with polymers to form corrugated roofing sheets. They are cheap and more durable. Since red mud corrugated roofing sheets are very flexible, they are extensively used as a light roofing material for temporary construction

6. **GALVALUME SHEET :** Galvalume sheets are commercially available light steel roofing sheets made up of lowtensile steel or mild steel. These sheets are 4 times more corrosive resistant than G.I. sheets and are one of the most economical and durable material. The versatility, ease of use, aesthetics and long term performance of the material makes it best preferred material for roofing

## **1.3 PAINTS AND VARNISHES**

Paints are coatings of fluid materials which are applied as a final finish to all surfaces such as walls, ceilings, wood work, metal work, etc. The process of application of paint as a coating material is called painting. The ingredients of paints and their functions are discussed below.

### **1.3.1 INGREDIENTS OF PAINT**

- |          |            |                       |
|----------|------------|-----------------------|
| 1) Base  | 2) Carrier |                       |
| 3) Drier | 4) Solvent | 5) Colouring pigments |

1. **BASE:** It is the main ingredient of paint. It hides the surface to be painted and imparts durability to the painted surface. Commonly used bases are white and red lead, zinc and iron oxides.

2. **CARRIER:** The carrier is a liquid which acts as a binder and helps to spread the ingredients uniformly on the painted surface. Linseed, Tung, Poppy, Sunflower oil etc are some of the commonly used carriers.

3. **DRIER:** Driers are metallic compounds used in small quantities for accelerating the process of drying of paint film. Litharge, Lead acetate, Manganese dioxide and Cobalt are the driers commonly used.
4. **SOLVENT:** Solvent or thinner is a liquid which thins the paint film so that it can be easily applied on the surface and it helps the paint in penetrating through porous surfaces. Turpentine, petroleum, spirit and highly solvent naphtha are commonly used as solvent.
5. **COLOURING PIGMENTS:** To obtain desired colour and shades of the paint, colouring pigments are added.

### **1.3.2 CHARACTERISTICS AND USES OF PAINTS**

#### **CHARACTERISTICS OF A PAINT**

- i) It should dry quickly.
- ii) It should be easy to apply and cover large surface area.
- iii) It should not be harmful to health
- iv) It should not react with the wall or wooden material
- v) The paint should not be affected by weathering actions of the atmosphere
- vi) The paint should form a hard and durable surface
- vii) The paint should be fairly cheap and economical

#### **USES**

- i) Protects the surfaces from the weathering effects of the atmosphere and actions by other liquid, fumes and gases.
- ii) Prevent the decay of wooden members.
- iii) Prevent the corrosion of metallic surface.
- iv) Provide a smooth surface for easy cleaning.
- v) Provide pleasing, colourful and decorative appearance to the surfaces.
- vi) Increase the life of the buildings.
- vii) It covers the defective workmanship and materials.

### **1.3.3 TYPES OF PAINTS**

1. **OIL PAINT:** This is an ordinary paint. It is generally applied in three coats namely priming coat, undercoats and finishing coats. It is very cheap and possesses opacity and low gloss.
2. **ENAMEL PAINT:** Enamel paint consists of white lead or zinc white ground in a small quantity of oil and mixed with petroleum spirit and resinous matter. It is available in different colours.
3. **EMULSION PAINT:** It consists of polyvinyl acetate and synthetic resin as binding materials. It is easy to apply and dries quickly. Colour of paint is retained for a long period. It can be cleaned by washing with water.

4. **ALUMINIUM PAINT:** Aluminium paint consists of aluminium powder suspended in spirit varnish or oil varnish. After the application of the paint the spirit becomes evaporated and the aluminium is deposited on the surface as thin layer. Aluminium paint has the advantage such as visibility in darkness, imperviousness to moisture, good appearance to the surface, high electrical resistance and resistance to heat and sunlight.

5. **BITUMINOUS PAINT:** It is prepared by dissolving asphalt or vegetable pigment in any type of oil or petroleum. It presents a black appearance. This type of paint is used to iron grills.

6. **CEMENT PAINT:** This type of paint is prepared by using white cement, pigment accelerators and other additives. It is available in a various colour and available in dry form. It is water - dilutable paint. It is mainly applied on brick and cement surface and resists the penetration of moisture. It gives long life.

7. **PLASTIC PAINT:** The paint contains necessary variety of plastics. It is available in the market under different trades and colours. The plastic paint can be applied either by brush or by spray painting. It gives recreation, pleasing and good appearance.

#### **1.3.4 COMPARISON BETWEEN ENAMEL PAINT AND CEMENT PAINT**

<b>Sl.No</b>	<b>Enamel Paint</b>	<b>Cement Paint</b>
<b>1</b>	It is available in different colours	It is also available in different colours
<b>2</b>	It consists of white lead or zinc white ground in a small quantity of oil and mixed with petroleum sprit and resinous matter	It is prepared by using white cement, pigment and other additives
<b>3</b>	It dries slowly	It dries quickly
<b>4</b>	It can be applied inside of rooms	It is applied only on rough surfaces

#### **1.3.5 METHOD OF PAINTING OLD AND NEW WOOD WORK**

##### **PREPARATION OF SURFACE FOR PAINTING OF THE OLD WOOD WORK**

- i) The surface of the old wood work should be cleaned by using sand paper.
- ii) Old surface should be cleaned by using a litre of water mixed with 200 gm of caustic soda and lime to remove the old colours.
- iii) Nails if any should be removed.

##### **PROCEDURE OF PAINTING OLD WOODEN SURFACE**

- i) Priming coat is applied on the surface to reduce quantity of oil paint.
- ii) After drying of the priming coat the first coat of paint is applied on the surface.
- iii) After drying of the first coat of paint second and third coats will be applied on the surface subsequently.



## **METHOD OF PAINTING NEW WOOD WORK**

1. **PREPARATION OF SURFACE FOR PAINTING:** The surface to be painted should be carefully cleaned and rendered smooth.
2. **KNOTTING:** Knotting is of three types. The commonly adopted two types are discussed below.
  - i. **ORDINARY KNOTTING:** This is applied in two coats. The first coat consists of hot lead ground in water with a strong glue added to it. After drying, the second coat is applied which consists of red lead ground in oil and thinned with turpentine. By doing this knots are removed.
  - ii. **PATENT KNOTTING:** This consists of two coats of varnish which is made by dissolving shellac in methylated spirit. Knots are removed by applying this mixture. Boiled lime is also used to remove knots.
3. **PRIMING COAT OR FIRST COAT:** After knotting the priming or first coat is applied to the whole surface of the wooden article to be painted.
4. **STOPPING:** After priming the process of stopping is carried out. After stopping dries, the surface is well rubbed down with emery sheets and cracks if any are filled with putty. This is known as stopping.
5. **APPLICATION OF THE SUCCEEDING COAT:** Painting is done by good quality brush. Finally, two coats of paint are applied one after the other. The second coat is applied only after the first coat is thoroughly dried. While painting, the brush is held at right angles to the surface and only the hairs should touch the surface. If necessary after drying of second coat the third coat is also applied.

## **1.3.6 METHOD OF PAINTING OLD AND NEW IRON AND STEEL WORKS**

### **PAINTING THE OLD IRON AND STEEL WORK**

#### **1. PREPARATION OF THE SURFACE**

- i) The iron and steel work to be painted is made free from all mill scale, loose rust and grease by using iron brushes.
- ii) The old paint on the iron work should be cleaned by using phosphoric acid.

#### **2. PAINTING THE OLD IRON AND STEEL WORK**

- 1) The surface to be painted is cleaned with emery sheet.
- 2) Holes if any on the surface should be filled with metallic paste. Then as the priming coat, red oxide is applied on the surface. This is cheap. Painting adheres well on it.

### **PAINTING THE NEW IRON AND STEEL WORK**

1. **PREPARATION OF THE SURFACE:** The iron or steel work to be painted is made free of all mill scale, loose rust and grease by using iron brushes. The loosened scales are removed by a jet of hot water, followed by a bath of hydrated lime and petroleum. Cleaned metal surface is finally treated with phosphoric acid.

**2. APPLICATION OF COATS OF PAINT:** Surface of steel work is cleaned and dried. After this a priming coat is applied. After this has dried the second coat of paint is applied by using brush or spray. The completed paint surface should be smooth and uniform.

### **1.3.7 PROCEDURE OF CEMENT PAINTING ON WALL SURFACE**

#### **PREPARATION OF SURFACE**

- i) Newly constructed wall surface is wet. The wall surface should not be painted until it is completely dry. Time duration for drying depends on the ventilation and weather condition. Painting on a freshly plastered surface should be avoided for at least 3 to 6 months.
- ii) The wall surface should be prepared well before painting to remove free lime or cement in the wall. Otherwise it will discolour the paint and destroy its oil. To avoid this priming coat is applied which does not consist of chemicals that reacts with alkaline.
- iii) Painting should be done only after the surface is given a coat of sizing (glue mixed with water) to fill up the cracks.
- iv) White patches that occurs on the plastered surface can be removed by water washing with wire brush. If white patches appear again painting should be delayed.
- v) While painting, if any change occurs antiseptic washing treatment is given.

#### **APPLICATION OF CEMENT PAINT**

- i) Initial coat of white cement is applied on the exterior walls
- ii) After curing is completed first coat primer is applied.
- iii) Above the primer coat 2 coats of cement paint is applied. Hence incomplete portions are finished by the second coat.
- iv) Finishing coat is applied in the opposite direction of the previous coat.

### **1.3.8 IMPORTANT POINTS TO BE CONSIDERED WHILE PAINTING**

- i. **BRUSH:** Brush used for painting should be of fibre bristles and not by using horse hairs. Only then more quantity of paint could be taken by the brush which will facilitate for easier painting. The brush should be cleaned by kerosene after the application of the paint.
- ii. **PAINTS:** Ready mixed paints available in the market can be used. Since it is highly expensive two or more colours of paint are kept in stock and the required colour may be changed according to the situation. For this, paint is taken in a solid state in a container and it is stirred well by adding linseed oil. Then by adding pigments for a required colour and suitable ingredients the paint is prepared.
- iii. **KNOTTING:** Before painting the wooden surface the process of removing knot on the surface by hiding it and painting over it is called knotting. Paint should be applied only after knotting.
- iv. **PRIMING COAT:** A coat of cheap rate paint is applied.

- v. **STOPPING:** After completing the first coat it should be rubbed by emery sheet and pumice stone. Then stopping is carried out and second coat is applied
- vi. **COATING:** Generally painting should be applied in 2 or 3 coats. Application of first coat is called priming coat. Second coat is called base coat. Third coat is called final coat.
- vii. **SPRAY PAINTING:** Instead of painting with ordinary brush the surface can also be painted with spray pistol by passing the air with pressure. This is called as “ Spray painting”. Spray painting is better then painting with brush. It includes special features like speed, quality, economy & labour.

### 1.3.9 DEFECTS IN PAINTING, CAUSES AND PRECAUTIONS

Sl.No	Defects	Causes	Precautions
1	Blistering	It is caused due to the trapping of water vapour behind the painted surface	Avoiding drops of water, water vapour on the painted surface
2	Blooming: Formation of dull patches on the finished surface	Due to bad ventilation and defective paint	Allowing sufficient ventilation and using good quality of paint.
3	Fading: Gradual loss of colour	Due to the direct sunlight effect	Avoiding direct sunlight and painting colours of light shades.
4	Flaking: Loosing of small portion of the painted surface	It is caused when the adhesion is poor	Painting on the surface which is having sufficient adhesiveness and allowing it to dry
5	Flashing: Glossy patches on the painted surface	Poor workmanship and poor quality paint	Good quality of paint is applied with an efficient painter
6	Grinning: Clear visibility of the background	Final coat of the paint does not have sufficient opacity	Final coat should be given with utmost care.
7	Running: Paint runs back and leaves small areas of surface uncoverd	When the surface to be painted is smooth	The surface to be painted should be rubbed with emery paper and painting is carried out
8	Wrinkling	The horizontal surface is too thickly painted	Thin coat of paint is applied on the horizontal surface

### **1.3.10 VARNISHES**

Varnish is a solution of resins or resinous substances like shellac, cobalt in oil, turpentine or alcohol.

#### **NECESSITY**

- i) To provide a brilliant and decorative covering on wooden surface.
- ii) To protect the painted surface from the atmospheric action.
- iii) To protect unpainted wooden surface of doors, windows, floors, roof trusses etc., from atmospheric action.

#### **1.3.10.1 INGREDIENTS OF VARNISHES**

- 1) Resin
- 2) Solvent
- 3) Drier

#### **1.3.10.2 TYPES OF VARNISH**

- 1. **OIL VARNISH:** The varnish which is prepared using linseed oil as solvent is known as oil varnish. Oil varnish is used both for interior as well as exterior works.
- 2. **SPIRIT VARNISH:** The varnish which is prepared using methylated spirits of wine as solvent is known as spirit varnish. It dries quickly. It is generally applied on the wooden surfaces. It is also known as 'French Polish'.
- 3. **TURPENTINE VARNISH:** These varnishes consist of soft resin like gum, dammer, mastic and resin dissolved in the best turpentine oil. This varnish dries quickly, but is not so durable.
- 4. **WATER VARNISH:** These varnishes are formed by dissolving shellac in hot water using enough quantity of ammonia, borax, potash (or) soda. Water varnishes are used for varnishing wall papers, maps, pictures, etc.

#### **1.3.10.3 PROPERTIES OF VARNISH**

- i) Gives brightness to the surface and a glossy look.
- ii) Varnish should not be allowed to dry quickly.
- iii) After varnish is applied the wood becomes hard.
- iv) Surface of the varnish applied will not allow the wood to shrink.

#### **1.3.10.4 USES OF VARNISHES**

- i) It gives permanent glossy film.
- ii) It is cheap when compared to paint.
- iii) It protects the surface from weathering

### **1.3.10.5 VARNISHING ON WOOD WORK**

**PREPARATION OF THE SURFACE:** Surface to be varnished must be made perfectly smooth with sand paper.

**REMOVING KNOTS:** Shellac and naphtha are added with varnish and it is applied on the knots and they are removed

**METHOD OF VARNISHING:** Varnish should be applied uniformly in very thin coats and sprinkling at angles and corners. The second coat should be applied only after the first coat becomes hard. The brush used for varnishing should be of fine haired type and not ordinary paint brush.

## **1.4 ADMIXTURES IN CEMENT**

Admixture is defined as a mineral or chemical substance that is added to cement mortar or concrete to increase its strength, durability, resistance against wear, water proofing capability, etc.

### **1.4.1 TYPES OF ADMIXTURES IN CEMENT**

1) Bonding mixtures

2) Plasticizers

3) Super Plasticizers

4) Antifungal admixtures

5) Colouring admixtures

6) Damp proofing and water proofing admixtures

7) Retarders

1. **BONDING MIXTURES:** This type of admixture is used for patching in old concrete works. It increases the strength and bond between old and new concrete. Natural and artificial rubber etc., are mixed to the cement concrete or cement mortar.
2. **PLASTICIZERS:** A plasticizer is defined as an admixture added to wet concrete mix to impart adequate workability properties. It is added to the fresh concrete to reduce the quantity of water to be used and thereby increase the strength of concrete.
3. **SUPER PLASTICIZERS:** Super plasticizers produce extreme workability. They achieve reduction in water content without loss of workability. Their use generally leads to an overall reduction in the cost.
4. **ANTIFUNGAL ADMIXTURES:** It is mixed to the concrete to protect the surfaces from bacteria, fungi, Phenol, Dieldrin, etc., are used as antifungal admixtures.
5. **COLOURING ADMIXTURES:** Natural and synthetic materials are used for producing various colours. Colouring pigments are added to cement in dry condition. It does not affect the strength and setting time of cement. To avoid the cracks on concrete surface, polypropylene fibres are added to concrete while adding colouring pigments. Metallic oxide and mineral pigments are generally used as colouring admixtures.

6. **DAMP PROOFING AND WATER PROOFING ADMIXTURES:** Presence of hygroscopic moisture on a surface is called dampness. Damp proofing admixtures are added to cement concrete to reduce the water absorbing power of concrete. Aluminium and Zinc Sulphate, Aluminium and Calcium Chloride are used as water proofing admixtures. They increase the strength of concrete.
7. **RETARDERS:** Retarders are added to concrete to increase the setting time of cement and also to reduce the water cement ratio. These are important types of admixtures used in the ready mix concrete industry for the purpose of retaining slump loss. Calcium Sulphate is the commonly used retarder. Other admixtures used as retarders are lignosulphonic acids and their salts and hydroxylates of carboxylic acid and their salts.

## **1.5 PLASTER OF PARIS**

5000 years ago Egyptians burnt the gypsum and they obtained plaster of paris. They used this powder for constructing monuments. The powder required for producing gypsum is largely available in paris. Hence it is called plaster of paris. Initially it was used in construction but now it is also used in medical fields and for manufacturing sports material.

### **1.5.1 USES OF PLASTER OF PARIS**

- i) Used for manufacturing chalk pieces, toys and decorative items
- ii) Used to prepare smooth finishing surfaces, false ceiling and to prepare smooth surfaces for painting.
- iii) Used to manufacture sculptures.
- iv) Used in orthopaedic and dental hospitals.
- v) Used in laboratories to close small openings in the equipments.

## **1.6 ACOUSTICS**

Acoustics is the science that deals with the origin, propagation and auditory sensation of sound.

### **1.6.1 ACOUSTICAL INSULATION MATERIALS**

1. **ACOUSTIC PLASTER:** It is a granulated insulation material mixed with cement. It is called as fibrous plaster. The quantity of cement used in such a material is decided so as to provide enough strength and have sufficient pores. Increase in quantity of cement will affect the acoustic property. Decrease in quantity of cement will reduce the strength of the plaster. The coefficient of absorption varies from 0.15 to 0.30.
2. **ACOUSTIC TILES:** These are commercially available materials manufactured in factories. It can be easily fixed in the walls. The absorption of sound is uniform. It is most suitable for small rooms. But it is costly compared to other acoustical materials.
3. **PLYWOOD:** Three to four thin sheets which are cut from the wooden planks are (veneer) placed such that the grains in each sheet are perpendicular to each other. Then they are pasted by vajram and pressed together in the machines.

4. **STRAW BOARD:** Straw boards are manufactured in hydraulic pressing machines by using chopped straw by chemical methods. These are best acoustic absorbent materials.
5. **FIBRE BOARD:** This material may be perforated or unperforated. These are available in 3 mm to 12 mm in thickness. It is manufactured in pressing machines by using wooden pulp.

## **1.7 PLASTICS**

Plastic was introduced during the 19<sup>th</sup> century by the industrialists. Plastic is one of the recent engineering materials. This is available in the market all over the world. Plastic is an organic substance and it consists of natural or synthetic binder or resins with or without moulding compounds.

### **1.7.1 USES OF PLASTICS**

Plastics are used in the manufacture of following materials

- i) Bath and sink units
- ii) Corrugated and plain sheets
- iii) Decorative laminate and mouldings
- iv) Electrical conduits
- v) Electrical insulations
- vi) Floor mates
- vii) Lighting fixtures
- viii) Paint and varnish
- ix) Pipes to carry cool water

### **1.7.2 TYPES OF PLASTICS**

The property of plastics can be changed due to increase or decrease in temperature. Based on that the plastics are classified into two types

- 1) Thermoplastics
- 2) Thermosetting plastics

#### **1. THERMOPLASTICS**

These plastics become soft when heated and hard when cooled. Thus it is possible to shape and reshape these plastics by heat and pressure as the process of softening and hardening may be repeated for an indefinite time unless the heat is not so high causing chemical decomposition. The main advantage is old scrap materials can be used again and again.

#### **2. THERMOSETTING PLASTICS**

This plastic become rigid when moulded at suitable pressure and temperature. This type of plastic passes originally through thermo-plastic stage. When they are heated to the temperature range of 127<sup>o</sup> C to 177<sup>o</sup> C they set permanently and further application of heat does not alter their form or soften them. The thermosetting plastics are soluble in alcohol and certain organic solvents. The thermosetting plastics are strong, durable and hard and are available in various colours and are also used in engineering applications.

## **1.8 PVC**

PVC is Polyvinyl Chloride.

### **1.8.1 ADVANTAGES OF PVC DOORS AND WINDOWS**

- i) PVC doors and windows offer high resistance to impact, weathering and fire.
- ii) They provide highest standard for quality, durability and efficiency.
- iii) Since they are fungal resistant, they do not require either painting or varnishing.
- iv) They are impervious to moisture.
- v) The cell design of PVC reduce heat loss and conductivity, making them great insulators.
- vi) Their smooth surface does not need any special care or maintenance
- vii) Light in weight, easy to handle and transport.
- viii) They can meet all demands. All desired shapes are available in a variety of colours and with different finishes.
- ix) They are flexible so that doors and windows can be made in many variety of shapes and sizes.
- x) Installation of PVC doors and windows are simple.

### **1.8.2 DISADVANTAGES OF PVC DOORS AND WINDOWS**

- i) PVC doors and windows are used only in unimportant places.
- ii) They are not safe.
- iii) There are possibilities of cracks while driving screws during installation.
- iv) The appearance of plastic doors and windows is not as pleasant or decorative as wooden ones.

### **1.8.3 ADVANTAGES OF PVC PIPES**

- i) Light in weight, easy to handle and transport.
- ii Durable and unaffected by fungi & insects.
- iii) Good electrical insulators.
- iv) They are available in required sizes and shapes.
- v) Free from corrosion.
- vi) They are cheaper than A.C pipes, Galvanized Iron pipes and Cast Iron pipes.
- vii) Placing, bending and installation are easy.
- viii) Have adequate strength and are resistant to shock.
- ix) Highly resistant to acidic water.
- x) PVC pipes resist vibration better than steel.

### **1.8.4 DISADVANTAGES OF PVC PIPES**

- i) Have low resistant to heat.
- ii) Expansion is high.
- iii) Some types of PVC impart taste and smell to water.
- iv) Difficult to obtain PVC pipes of uniform composition.



## 1.9 MODERN CONSTRUCTION MATERIALS

**1.9.1 CERAMICS:** Ceramics means the technology and the art of making objects with clay and similar materials by treating with fire. In buildings, ceramics are used for roof and floor tiles.

Common types of ceramic tiles used in construction are

- i) Common clay floor tiles
- ii) Clay terracing tiles
- iii) Clay ceiling tiles
- iv) Glazed ceiling tiles
- v) Fully vitrified tiles
- vi) Porcelain tiles

**1.9.2 GLASS:** Glass is any substance or mixture of substances that has solidified from the liquid state without crystallization. It absorbs, refracts or transmits light. It is an excellent electrical insulator, extremely brittle, not affected by air water and ordinary chemicals. It is available in beautiful colours and capable of being worked in several ways. Glass is widely used for pavement lights, partitions, lantern lights, door and window panels, and as roof covering material in industrial buildings, factories etc.

**1.9.3 ELECTRICAL INSULATING MATERIALS:** Electrical insulating materials are defined as materials which offer a very large resistance to flow of current and for that reason they are used to keep the current in its proper path along the conductor. A good electrical insulator should have large insulation resistance, high dielectric strength, least thermal expansion and high thermal conductivity. Commonly used electric insulators are mica, wood, slate, glass, porcelain, rubber etc.

**1.9.4 FLY ASH:** Fly ash is the residue obtained from the combustion of coal in thermal power plants. It is used in concrete as an admixture or in part replacement of cement, fine aggregate or both. It has low thermal conductivity, stable against temperature and humidity variations, better sound insulation and better strength to weight ratio.

**1.9.5 GYPSUM:** Gypsum is hydrated sulphate of calcium. It is white crystalline substance sparingly soluble in water. It is used as a binding material since it sets and hardens quickly.

**1.9.6 RUBBER:** Rubber also known as “elastomer” is a type of polymer which possesses good elasticity and high resistance to corrosion. It is available in natural and synthetic forms. It is used for thermal insulation, flexible tubing, adhesive, hose pipes, mounting material, as a buffer and gasketing material.

**1.9.7 COMPOSITE MATERIALS:** A composite material is a combination of two or more materials. It has compositional variations and depicting properties distinctively different from those of the individual materials of the composite. The composite material is generally better than any of the individual components as regard to their strength, heat resistance and stiffness.

Examples: Pearlitic steels, plywood, RCC, etc.

## QUESTIONS

### PART - A

Choose the correct Answer

(1 mark each)

- 1) The top portion of the building constructed to protect it from heat, rain, snow and wind is called as \_\_\_\_\_.  
a) Hip                      b) Gable                      c) Roof                      d) Batten
- 2) In a sloping roof, the inclined wooden member that connects the top of the truss to the eave is called as \_\_\_\_\_.  
a) Hip                      b) Eaves                      c) Pitch                      d) Rafter
- 3) The frame made up of wood or steel placed across to hold the rafters in position is called \_\_\_\_\_.  
a) Battens                      b) Purlin                      c) Rise                      d) Valley
- 4) A roof form by joining two inclined rafters together is called \_\_\_\_\_.  
a) Single lean-roof                      b) Purlin roof                      c) couple roof                      d) Collar beam roof.
- 5) The percentage of asbestos fibres used in the manufacture of asbestos cement sheets is about  
a) 33.3%                      b) 27%                      c) 15%                      d) 18%.
- 6) For a roof to be called as a flat roof the maximum permitted slope is  
a) 22°                      b) 10°                      c) 15°                      d) 18°
- 7) The thickness of corrugated AC sheet is  
a) 8mm                      b) 5mm                      c) 6mm                      d) 7mm
- 8) Madras Terrace roof was widely used in  
a) Andrapradesh                      b) Karnataka                      c) Kerala                      d) Tamil nadu
- 9) Main ingredient of paint is \_\_\_\_\_.  
a) Drier                      b) Base                      c) Colouring Pigment                      d) Solvent
- 10) To obtain desired colour in paint \_\_\_\_\_ is used  
a) Carrier                      b) Drier                      c) Colouring Pigment                      d) Base
- 11) The thickness of corrugated aluminium sheets vary from \_\_\_ to \_\_\_ mm  
a) 0.2 to 0.6                      b) 0.7 to 0.9                      c) 0.5 to 0.8                      d) 0.3 to 0.5
- 12) From \_\_\_\_\_ industry wastes red mud is obtained which is used for manufacture of red mud corrugated sheets  
a) Paper                      b) Chemical                      c) Iron and Steel                      d) Aluminium
- 13) \_\_\_\_\_ tiles are made up of clay and similar material  
a) Glass                      b) Ceramic                      c) Fly ash                      d) Rubber
- 14) \_\_\_\_\_ is obtained from thermal power plant by the combustion of coal  
a) Gypsum                      b) Rubber                      c) Fly ash                      d) Glass
- 15) Rubber is also called as \_\_\_\_\_.  
a) Composite material                      b) Ceramics                      c) Elastomer                      d) Gypsum
- 16) \_\_\_\_\_ is called as Hydrated Calcium Sulphate  
a) Fly ash                      b) Ceramics                      c) Glass                      d) Gypsum

**Answer in one or two words**

**(1 mark each)**

- 1) Mention any two types of triangular trussed roofs
- 2) What are the main ingredients of Varnish?
- 3) How are roofs classified?
- 4) What is meant by flat roof?
- 5) What is a single lean-to roof?
- 6) What is purlin?
- 7) What is rise in a pitched roof?
- 8) What is pitch?
- 9) Mention any two types of ceramic tiles.
- 10) Mention any two uses of glass.
- 11) Write any two electrical insulators used.
- 12) How fly ash is obtained?
- 13) What do you know about gypsum?
- 14) Mention any two uses of rubber in building construction.
- 15) Give two examples of composite materials.

**PART B**

**Answer in one or two sentences**

**(4 marks each)**

- 1) What is meant by “King Post Truss”?
- 2) What is meant by “Asbestos Cement Sheet”?
- 3) What are the uses of paints?
- 4) Distinguish between enamel paint and cement paint.
- 5) What is meant by Plaster of Paris?
- 6) Write short notes on weathering course
- 7) What are the requirements of good roof?
- 8) What do you mean by ceramics? Mention any three types of ceramics
- 9) Define "Electrical insulation material".

## PART C

### Answer shortly

(10 marks each)

- 1) What are the different types of trussed roofs? Explain.
- 2) Differentiate between couple roof and couple closed roof.
- 3) Distinguish between “Asbestos Cement Sheet ” and “Galvanized Iron Sheet”.
- 4) Write about any four types of paints.
- 5) Explain the procedure adopted in painting old and new wood works.
- 6) Explain the procedure of applying “cement paint” on walls.
- 7) What are the different types of plastics? Explain.
- 8) Explain the procedure of painting old & new iron and steel works.
- 9) Define the following
  - i) Base
  - ii) Colouring pigments
  - iii) Carrier
  - iv) Solvent
  - v) Drier
- 10) Write short notes on the following:
  - i) Centering
  - ii) Curing & removal of formwork
  - iii) Weathering course
- 11) Explain Madras Terrace roof?

## PART D

### Answer in Detail

(20 marks each)

- 1) Mention the different sheets available for covering sloped roofing. Explain them.
- 2) Explain the types of paints and their uses.
- 3) What are the important factors to be kept in mind while painting? Explain.
- 4) a) What is meant by PVC? State the advantages and disadvantages of PVC doors and windows.  
b) What are the advantages and disadvantages of PVC pipes?
- 5) What are the admixtures used in cement? Explain.
- 6) Write the types of new roofing materials and explain in detail.
- 7) Write any five types of modern construction materials and describe them.

### ANSWERS

- 1)c 2)d 3)b 4)c 5)d 6)c 7)b 8) c 9)d 10)b 11)c  
12)c 13)d 14)b 15)c 16)c 17)c

## **UNIT - II**

### **PLANNING OF HOUSE**

#### **2.1 INTRODUCTION**

One of the basic needs of mankind is house. During ancient times man used to live in dens. As the culture of mankind improved, science and technology also developed. Man utilized this technological development in building his house with all sophistications and facilities.

##### **2.1.1 IMPORTANCE OF HOUSE**

- i) A house is a shelter for man, constructed of stones, mud and other naturally available materials. It consists of walls, floor, roof, doors and windows. It is in this house, man gets rid of the outside busy life and worries and relaxes and rests peacefully.
- ii) A house protects the family from severe heat, cold, rain, storm and also from anti social elements.
- iii) A house binds the family members with love and affection. It brings them closer and helps them to understand each other and live together.
- iv) For the general activities of a family like, cooking, serving, washing, cleaning, saving materials, welcoming the guests, disposing the wastes etc., and for individual activities like reading, relaxing, sleeping, bathing etc., a house forms the centre.
- v) House facilitates a man to express his feelings and to act independently.
- vi) A well planned and good house provides privacy, adequate rest and a healthy atmosphere to the family. It provides them feelings of governance, vision, affection and protection.
- vii) It is in a house where an individual understands the heritage of his family, culture and habits.
- viii) A house provides love, affection and care to those people who cannot manage themselves like the sick, unemployed, aged, widow and physically handicapped.
- ix) A house and its surrounding depicts the fame of the family.
- x) One of the factors which decides the status of a family is the house in which they live. Not only this, the development of a nation can also be measured by the colonies of houses in it.

Owing to the above reasons the importance of a good house is known.

## **2.1.2 ORIENTATION**

For a healthy life, the natural resources like sunlight, clean air and sufficient rain are mandatory requirements. But at the same time care should be taken to see that these do not affect the people residing in a dwelling. For this, the orientation of the house constructed in a particular plot is important. The entrance of the house and the orientation of the house should be in such a way that it allows adequate sunlight in the morning and also prevents the inmates from excessive heat during the day. The doors and windows should be so placed and arranged so as to allow adequate wind as and when required. It is always better to have a verandah in front of the house. The verandah should be constructed in such a way that it does not allow mist and drizzle inside and also reduce the heat of hot air to certain extent before allowing it inside the house. Each room should be oriented and placed depending upon the nature of activity it is intended for. For example, the kitchen which will be mostly utilized during the day has to be arranged in the east or north part of the home. At the south or southwest bedroom should be arranged. Moreover care should be taken for sufficient air and ventilation to these rooms.

## **2.2 SITE SELECTION**

Since a house forms one of the basic requirement of man, to satisfy this he has to initially select a suitable site for construction. Each and every individual spend a major portion of their saving for purchasing a site and house construction. Most of the people do not move away or change their house. Therefore a good sense regarding site selection and house construction in it becomes necessary.

### **2.2.1 FACTORS TO BE CONSIDERED DURING SITE SELECTION**

#### **1. Physical features:**

- i) The plot should be regular with well-defined boundaries on all four sides.
- ii) It is better to have an elevated plot when compared to its surroundings since rain water does not stagnate in elevated areas and drain off quickly to other low lying areas. Such a plot becomes ideal for dwelling.
- iii) If the house is constructed on a elevated plot the house could be better visualized.
- iv) If the site is a low lying area, it allows rain water to stagnate and flies, mosquitoes and other insects breed in it leading to unhealthy living conditions.
- v) It is always better to choose a site oriented towards north-south directions for better air flow.

#### **2. Soil conditions:**

Before constructing the house, it is always advisable to check the properties of soil. This will avoid unnecessary problems during construction and prevent loss of money.

- i). Clayey soil does not absorb water and retains it. Therefore clayey soil is not good for construction. At the same time sandy soil absorb water very quickly and hence a strong foundation cannot be laid on it. Moreover sandy soil is not suited for gardening.
- ii) Though strong foundation could be laid on a rocky strata, it does not drain water. Digging of well becomes extremely difficult and lot of money has to be spent. Therefore a rocky strata is also not an ideal site for house construction and moreover plants do not grow on rocks. During summer when the ground gets heated, rocky layer radiates the heat during night.
- iii) Hence a site consisting of soft soil at the top and hard soil at a depth of 0.9 to 1.2 m ideally suited for house construction.

### **3. Sanitary facilities:**

- i) The area surrounding the proposed plot of house construction should be free from stagnated water, small ponds and deteriorated wells.
- ii) Care should be taken to see that there are no drainage or public toilets near the plot.
- iii) For the benefit of the family members the plot should not be selected near cow sheds, poultry farms, industries and burial/cremation grounds.
- iv) Low lying areas which were later filled up with garbage and other city wastes and disposed materials should never be selected for house construction. The bearing capacity of such areas will be very less and the foundation will not be firm or strong. Moreover at times of heavy rain, these dumped up areas become saturated and promote the breeding of mosquitoes and flies polluting the surrounding atmosphere with foul smell and causing threat to health.
- v) It is advisable to select a plot with fresh air, adequate light, good water supply and modern sanitary facilities.

### **4. Practical Conveniences:**

- i) A plot is rated based on the basic facilities that are available around it.
- ii) A plot should be located in such a way that schools, post & telegraph office, public telephone, bank, hospital, maternity centre, market and shops are at walkable distances.
- iii) If bus stand, railway station etc., are nearby the proposed plot of house construction, it will be very convenient for the family members to reach their offices, colleges or schools.

### **5. Neighbourhood:**

- i) For guaranteed permanent happiness of the family members it is always better to purchase a plot in a good developed locality.
- ii) The plot should be chosen in such a locality where the neighbours residing there are of the same status when compared to us both socially and economically.

- iii) Taking into consideration the safety of the family members, the plot should be chosen in a developed locality or in a developing locality.
- iv) If the plot is adjacent to sea shore, one could enjoy the freshening sea breeze. But at the same time the chlorides present in sea breeze can corrode the steel cupboards, furniture, window and door grills etc., quickly.
- v) The plot should not be affected by heavy traffic sounds and dangers. Dust particles and infectious germs due to heavy traffic create ill-health.

#### 6. Legal Characteristics:

- i) Before choosing a plot in a particular locality it is good to know all the legal aspects completely regarding the plot and the locality in which it is situated.
- ii) The plot should be free from any encumbrance.
- iii) It is advisable to consult a lawyer and get legal opinion regarding the plot. The boundaries of the plot have to be predicted properly and its area has to be checked. It is good to purchase a plot which confirms the bye laws laid by the Municipality, Town Panchayat or Chennai Metropolitan Development Authority (CMDA).

#### **2.2.2 PRINCIPLES OF ORGANIZING A HOUSE:**

Though a plot may be of any geometric shape, there are certain principles which govern the shape of the building to be constructed in it.

They are

- 1) External appearance
- 2) Front elevation
- 3) Privacy
- 4) Grouping of rooms
- 5) Roominess
- 6) Circulation
- 7) Flexibility
- 8) Sanitation
- 9) Facilities for furniture arrangement and
- 10) Practical considerations.



## 1.EXTERNAL APPEARANCE:

External appearance mainly includes location of doors and windows. The doors and windows shall be located in such a way that natural resources like fresh air, sunlight, natural scenery etc., are enjoyed to the maximum extent.

A well organized exterior of the house provides hygienic conditions and proper location of doors and windows ensures adequate sunlight in appropriate rooms and also appropriate positioning facilitates penetration of sunlight. Kitchen should be positioned facing the east direction. Only then the sun's rays in the morning could destroy the germs and purify the air. Bed room should be located in the south or southwest direction for better breeze and air circulation. Living room can be located in the northeast or facing south east direction.

## 2.FRONT ELEVATION:

A good house should be capable of developing various thoughts in a person's mind when it is viewed from outside. The view of the house should be attractive. It should be modern and constructed with various facilities and by looking it from front it should develop a sort of well-being and happiness in the viewer's mind. A beautiful balcony, carved pillars, simple and modern roofs will provide good aesthetics in front elevation for a house.

## 3. PRIVACY:

It is important to take into consideration the privacy of each and every room in a house.

Privacy is of two types:

- i) Privacy of individual room from other rooms and verandah
- ii) Privacy of entire house from street

Trees or creepers can be grown in front of the house so that privacy can be obtained for the house from street. While positioning the rooms, care should be taken to see that the doors, windows of the rooms do not face each other. If necessary curtains could be utilized to create privacy. The above points should definitely be considered particularly while construction of bedroom, bath room and water closet.

## 4. GROUPING OF ROOMS:

Based on the routine works that are performed in a house, the rooms shall be arranged adjacent to each other.

To simplify the utility of the family members, dining hall should be placed adjacent to the kitchen, living room adjacent to the verandah and bathroom & water closet should be constructed adjacent to the bedroom.

## 5. ROOMINESS:

A house should be planned and constructed in such a way that the interior of the house is magnified to the maximum extent possible. The available area should be well planned so that not even a small bit of area is left unutilized. Shelves could be constructed in the walls to store articles and lofts could be constructed beneath the roof to store articles, by this way the carpet area of the house could be maximized. The space available beneath the staircase could be covered and also utilized for storing articles. The size and shape of a room, the number and arrangement of furnitures in it and its interior wall colour could be well proportioned and applied so as to show its size to the maximum extent possible.

## 6. CIRCULATION:

The path leading from one room to another should be simple, straight and short. It is better to provide separate entrance for every room or the entrance for individual rooms could be from a common passage. None of the rooms should have their entrance positioned in another room. For example, the entrance to kitchen should not be inside bed room. This will a be disturbance or will lead to inconvenience to the person in bedroom. Therefore such inconveniences have to be avoided. Proper positioning of rooms and proper arrangement of furnitures like sofa, tables and chairs towards the corner of the walls will facilitate uninterrupted walking space inside a house.

## 7. FLEXIBILITY:

The utility of a room should not only be for a particular purpose. Instead it should be flexible enough to adopt to various other utilities according to the need. It will solve the space problem. For example if the living room is constructed slightly bigger in size, a portion of it could be utilized for dining and also could be utilized for sleeping during night times. Utilising the kitchen itself for dining purposes, utilizing the verandah adjacent to the kitchen as the play area for small kids will solve space problems to a certain extent. Curtains, folding wooden or metallic screens, almirahs, plywood boards etc., could be used to partition the common area and separate space could be created for various activities.

## 8. SANITATION :

A house should always be constructed with good ventilation, proper lighting and general sanitation facilities. Proper planning should be done to drain waste water from kitchen, bathroom and water closet in a hygienic way.

## 9. PLACEMENT OF FURNITURE :

A room in a house should be planned and constructed in such a way keeping in mind the furnitures that are to be placed in it. The positions of sofa sets, tables and chairs and their sizes should be so fixed initially keeping in view the position and size of door and window openings and shelves in the wall.

## 10. PRACTICAL CONSIDERATIONS :

Since a house is an asset which cannot be shifted from one place to another, the following points should be considered while planning and constructing a house.

- i) It should possess a strong structural integrity.
- ii) Should have all facilities within.
- iii) Should have simple structural configurations.
- iv) It should be attractive.
- v) It should be flexible to adapt to the needs of the future expansion without being demolished and reconstructed.
- vi) Above all unnecessary construction costs should be avoided and entire construction should be carried out thriftly.

## 2.3 HOUSE PLAN

Before constructing a house, it should be planned and presented in a drawing form on paper.

Following details could be obtained from the plan of a house :

- i) General arrangement of all the rooms in the house.
- ii) The length and breadth of individual rooms.
- iii) Wall thickness.
- iv) The numbers and positions of doors, windows and cupboards/ shelves.

For an enjoyable luxurious family life, adequate space for family members and furnitures are very important. Moreover for the family members to express their views and tastes, important day to day activities like entering the house, relaxation, entertainment, cooking, eating, sleeping, bathing and saving their valuables etc. a comfortable and adequate spacing is more important. Arranging rooms in a proper way for all the above is the important feature of house planning.

### 2.3.1 ROOMS IN A HOUSE

- 1) Verandah
- 2) Living room
- 3) Bed room
- 4) Kitchen
- 5) Dining room

6) Pooja room

7) Bath room

### **1. Verandah:**

A verandah is constructed in the entrance of a house. It is beneficial in the following ways.

- i) Strange people could be seated in the verandah.
- ii) Articles like umbrella, walking stick and chappals could be left in the verandah and also bicycles and two-wheelers could be parked in it.
- iii) Its the place where family members get together and sit during evenings or nights to obtain fresh breeze.
- iv) Pet animals could be tied in the verandah.
- v) Its the place where plants could be grown in pots.
- vi) Verandah at the back of the house could be utilised for drying clothes and utensils after washing.
- vii) Care should be taken to see that the span of the verandah does not exceed 3m.

### **2. Living Room:**



**Fig. 2.1 LIVING ROOM**

- i) The room next to the front verandah is the living room.
- ii) This room is also called as drawing room.
- iii) A living room should fulfill the various desires of the family members. For example it should be sufficient enough for all the family members to get together and enjoy, for hospitality of guests, for little children to play, for reading newspaper, for listening music etc..
- iv) Sometimes the living room is utilized for small parties. eg. "Birthday party".
- v) Due to shortage of space, in certain houses the living room is utilized as study room and bedroom during nights. Sometimes it gets converted as a guest room.

- vi) The living room should expose the general attitude of the family. It should provide a warm reception to the guests.
- vii) It should possess sufficient lighting, good ventilation and healthy atmosphere.
- viii) A living room should not be less than 4.5 m in length and 3.6 m in breadth. The shelves constructed in the walls should not be less than 90 cm in width.
- ix) For sufficient privacy, the door of the living room should be positioned in a corner and not at the centre.
- x) Based on the living room, furnitures should be placed to derive maximum benefits and comforts. Following are some of the furnitures and articles that could be placed in a living room. Sofa - for comfortable seating and discussion, easy chair for relaxation, teapoy for necessary hospitality to guests, table and chair for studying, radio and television for entertainment, built-in cupboards for placing articles and music system.
- xj) A living room could further be decorated by suitable pictures, flower arrangements, carpets etc., Artistic items and sculptures could be neatly arranged in a showcase or shelf that is available in a living room.

### 3. Bed Room:



**Fig. 2.2 BED ROOM**

- i) People spend one-third of their life in sleeping.
- ii) A bedroom is not only utilized for sleeping but it is also used for storing dress materials and for changing dresses.
- iii) Generally a room of size 4.50 m x 3.60 m is ideally suited for a bed room.
- iv) Care should be taken to see that the width of the bed room is not less than 3m.
- v) A rectangular shape offers better comfort than a square shaped bed room.
- vi) Air circulation is most important for a bed room. This room should be oriented towards the wind direction.

- vii) The door of the bedroom should be positioned in a corner so that when the door is opened the cot inside the bedroom is not visible from outside.
- viii) It is necessary to provide a small bathroom cum water closet adjacent to the bedroom
- ix) A small space should be provided in this room for storing clothes. Bedspreads, pillow covers, dress materials etc., can be stored in built-in cupboards or shelves.
- x) A small table and chair could be arranged adjacent to the cot for reading magazines. Entertaining books, a table lamp and a flower vase could be placed on this table.
- xi) It is better to provide separate bedrooms for children above 10 years and parents.

#### **4. Kitchen**

- i) Kitchen is supposed to be the major work area for the women in the house. It is in this place the food for the entire family is cooked.
- ii) In this room, provisions, utensils etc. are stored and electrical appliances for cooking like grinder, mixie etc. are being operated.
- iii) Sometimes kitchen is also used for dining purposes.
- iv) The happiness of the family members, their health etc. depend on the food that is cooked and the happiness of the women who cooks the food.
- v) Since she spends most of her time in kitchen, care should be taken to see that the kitchen is spacious with sufficient air circulation and sunlight.
- vi) The kitchen should be oriented towards east or north east directions for sufficient sunlight to enter during the day. This purifies the air and provides warmth in the room. In the evenings the kitchen becomes cooler.
- vii) The size of the kitchen should be appropriately fixed for efficient functioning. It should neither be too big nor too small. A big kitchen leads to unnecessary walking in it and at the same time it will be difficult to walk during cooking if the kitchen is too small.
- viii) A kitchen should be constructed at least to a size of 2.4m x 3m or 3m x 3.6m and not less than this.
- ix) Unnecessary walking within the kitchen could be avoided if work centers are properly planned and positioned.
- x) Major three work centers to be arranged in a kitchen are a) Preparation Centre b) Cooking Centre and c) Washing Centre.

- xi) The items required for the corresponding working centers should be made available in the respective centers. For this cupboards/shelves should be constructed in these work centers to place the items required in it.
- xii) The work centers in the kitchen should be arranged closer to each other in the form of a triangle. A platform at a convenient height, made of cement concrete should be provided over which coddapah slab or granite slab could be placed so as to facilitate for standing and cooking. It helps to cook with ease and without getting tired. Also cleaning these slabs are easy.
- xiii) A kitchen platform for better performance could be in the form of L, U.

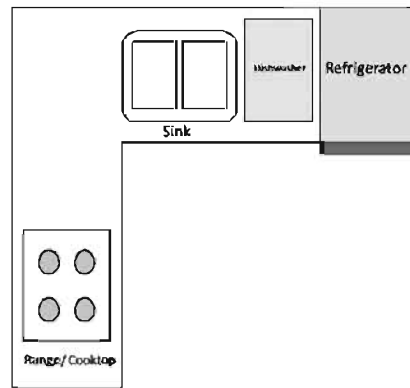

**'L' Type kitchen**

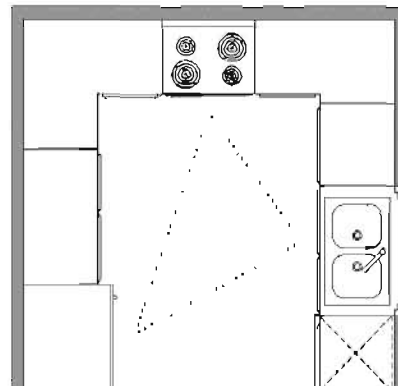

**'U' Type kitchen**

**Fig. 2.3 KITCHEN**

## 5. Dining Room:



**Fig. 2.4 DINING ROOM**

- i) This room should be arranged adjacent to the kitchen. Only then it will be easy to serve the cooked food.
- ii) If properly planned, the closed verandah adjacent to kitchen could also be utilized for dining purposes.
- iii) Nowadays people use table and chairs for dining. Hence a rectangular shaped dining room with a rectangular dining table in it with dining chairs around will be ideal and convenient.
- iv) Chairs should be placed so as to provide maximum comfort while dining.
- v) The dining place should have adequate sunlight and air circulation and it should also be beautiful with a pleasing look.
- vi) The dining room should always be kept clean and tidy so that flies, cockroaches etc. are avoided.

## 6. Pooja room

In every house there should be a small space for worshipping god. Hence a pooja room for worshipping god could be planned in a calm portion of the house.

## 7. Bath room

- i) The main objective of this room is to provide adequate facilities for taking bath and washing clothes. Therefore the size and shape of this room should be sufficient enough to offer the above facilities.
- ii) If facilities are provided inside the bathroom to heat water, then the size of the bathroom should be at least 1.80m x 2.40m.
- iii) A small shelf or plank could be fixed in the bathroom wall so that soap, towel, tooth paste, tooth brush etc. could be placed in it.



- iv) The bathroom should be so oriented so that sufficient sunlight is available in it.
- v) The floor of the bathroom should be non-slippery and it should not catch stains and it should be easily washable.
- vi) Porcelain tiles could be affixed on the wall from the floor to a height of 2m so that its glossy exterior will not catch stains easily and the bathroom will always look clean.
- vii) In modern residential buildings, particularly in big houses bathroom and water closet are combined in a single room and attached to the master bedroom. Still, it is essential to have a common bathroom and toilet.



**Fig. 2.5 BATH ROOM**

## **2.4 HOUSING**

Next to food, the important need for people is shelter. We consider it as one of the basic needs of mankind. A house is highly essential to protect us from rain, wind and heat. A proper housing is a must for today's social life. As roads and streets are considered important in an urban pattern, houses and their arrangement also attain importance.

Housing doesn't mean mere shelter. It includes hygienic, peace and the environment. Therefore urbanization should be kept in mind while planning for basic housing. When zoning is done for residential purposes modern thoughts and predications regarding the future should be considered.

Housing doesn't mean merely the space for a residential building or a strong residential building. Only if all the various basic facilities are considered it could be called a housing.

The reason for concentrating on urbanization to such a large extent is that the urban people should live happily with all basic arrangements and facilities. Therefore the fundamental of urbanization starts with good housing.

The success or failure of any urban pattern lies in the arrangement of housing in it.

In any urban pattern, a large amount of area is allocated for residential purposes of the people. Based on the number of residential units only other facilities like roads, commercial complexes etc., get their due share of land allotted.

The majority of fund required for implementing basic amenities in a city like drinking water, drainage, roads etc.. are collected from people in various forms of taxes. Therefore in any urban pattern, its revenue administration depends on its population, commerce, income of people and so on.

Therefore a town planner should always plan well in advance and execute it in such a way so as to meet the residential demands of all categories of people.

#### **2.4.1 HOUSING DEMAND**

Let us discuss in detail the factors that increase the housing demand.

- i) If housing loans are available for a low interest rate, then the need for housing demand will increase.
- ii) It also depends on the availability of skilled labour. If good number of skilled labourers are available, then people will be inclined to construct houses without delay.
- iii) Availability of good road facilities is also one of the major reasons for housing development. For example if a housing site is available in a place which doesn't have good roads, no one will be prepared to construct their houses in that area.
- iv) Real estaters should develop plots in an area with all basic amenities and then sell it. Only then people will tend to construct houses immediately.
- v) Huge population, less number of houses, surrounding environment and basic facilities are the reasons for increase in development of housing units.

#### **2.4.2 TYPES OF RESIDENTIAL HOUSES**

- 1) Detached houses or independent houses
- 2) Semi-detached houses
- 3) Row houses
- 4) Apartments or flats
- 5) Skyscrapers

##### **1. Detached houses or independent houses**

Houses which are alone and independent (Fig 2.6) could be classified under this category. Small size, large size & houses with gardens surrounding them have the following advantages.

Independent houses have good air circulation, ample lighting and there is always a feasibility for extending or modifying the existing house in its own land.



**Fig. 2.6 DETACHED HOUSE**

Houses of such type are constructed based upon the availability of lands and financial prospects. If the plots are available for a lesser price and if the construction materials are readily and cheaply available, then one could utilize such opportunities for the construction of detached or independent houses.

However such houses are luxurious and not thrift enough.

## 2. Semi-detached houses:

If an independent single house is separated into two for two families to reside then it is considered as “ semi detached house” (Fig. 2.7.)

A common wall is used to separate the two houses. If sufficient frontage is allowed in the front for both the houses, then it could be utilized in common by both the families.



**Fig. 2.7 SEMI-DETACHED HOUSE**

## 3. Row houses:

Row houses (Fig. 2.8) are generally constructed for labourers and people working on daily wages. The reason is that row houses are economical, suiting to their financial status.

Such houses will have only the minimum basic amenities. Bathrooms and toilets will be in common. Cost of such construction is very low. Therefore more number of people could be provided housing at lesser cost. Such row houses could be constructed with one or two floors.



**Fig. 2.8 ROW HOUSES**

## 4. Apartments or Flats:

In prime locations and in congested localities of a city, it is difficult even for high income group people to purchase a plot and construct a house of their own. This lead to the construction of apartments or flats (Fig 2.9) in the prime locations of the city.

In a situation where many families reside or live, apartments are constructed with facilities as obtained in an independent house. Apartments consisting of three or four rooms with separate parking area for cars and other vehicles are being constructed.



**Fig. 2.9 APARTMENT**

The cost of construction is much reduced when compared to the construction cost of an independent house. The reason being, the cost of the land is shared and also the cost involved in common facilities is divided among the families.

**Disadvantages:**

- ◆ Not suited for large families with lot of children
- ❖ Not possible to renovate, change, demolish or reconstruct the house.

**5. Skyscrapers:**

Skyscrapers are generally buildings of many storeys seeming to touch the sky when looked from the ground.(Fig 2.10)

In metropolitan and cosmopolitan cities the costs of the lands in major areas are too high and also rarely available. Therefore the technology of construction of residential buildings with several floors generally termed as skyscrapers came into existence and started developing.



**Fig. 2.10 SKYSCRAPERS**

The main advantage of such tall buildings is that, its residents are free from the atmospheric pollution particularly those who reside in the upper floors.

Since skyscrapers are constructed vertically, the land beneath is better utilised in the sense that a small area of land is sufficient enough for large number of families to reside.

But children and aged people find it difficult to negotiate the steps in skyscrapers and hence lifts or elevators become a must in such buildings.

These skyscrapers are sometimes dangerous in localities through which microwave transmissions are propagated and aero planes fly at low heights. Also it is not so easy to maintain such huge buildings. Therefore before construction of skyscrapers various factors have to be taken into consideration. Wind velocity and earthquake forces have to be definitely taken into account while designing such high rise buildings.

# QUESTIONS

## PART A

Choose the correct Answer

(1 mark each)

- 1) It is always better to have the \_\_\_\_\_ in front of the house.  
a) living room      b) stair case      c) verandah      d) kitchen
- 2) Clayey soil is \_\_\_\_\_ for construction.  
a) ideal      b) not suitable      c) recommended      d) dangerous
- 3) Food items, provisions, utensils, grinder, mixie are stored in  
a) drawing room      b) dining room      c) living room      d) kitchen
- 4) The room next to the front verandah is the \_\_\_\_\_  
a) bathroom      b) kitchen room  
c) pooja room      d) drawing room or living room
- 5) The success or failure of any urban pattern lies in the arrangement of \_\_\_\_\_ in it.  
a) street      b) factories      c) bus stand      d) housing
- 6) \_\_\_\_\_ is also one of the major reasons for housing development.  
a) Hospital      b) Market      c) Temple      d) Road facility
- 7) \_\_\_\_\_ are some times dangerous in localities through which microwave transmissions are propagated and aeroplane fly at low heights.  
a) Apartment      b) Detached houses      c) Sky Scrappers      d) Row houses
- 8) A plot is rated based on the \_\_\_\_\_ that are available around it  
a) basic facilities      b) agricultural land      c) aerodram      d) banks
- 9) \_\_\_\_\_ facilitates a man to express his feelings and to act independently.  
a) Hospital      b) Temple      c) House      d) Caves
- 10) Pet animals could be tied in \_\_\_\_\_  
a) verandah      b) living room      c) kitchen room      d) dining room

Answer in one or two words

(1 mark each)

- 1) Why clayey soil is not recommended for the construction of a house?
- 2) What are the three working centers to be arranged in the construction of kitchen?
- 3) For whom, row houses are constructed? Why?
- 4) What are the disadvantages of apartments?
- 5) What is the minimum size of a kitchen room?

## Part B

Answer in one or two sentences

(4 marks each)

- 1) How will you follow the roominess while constructing a house?
- 2) How are the sanitary facilities improved in the construction of a house?
- 3) What are the types of residential houses?
- 4) Why apartments are becoming popular nowadays?
- 5) What are the factors to be considered during site selection for the construction of a house?
- 6) Write any five factors of the principles of organizing a house?
- 7) What are the points to be considered before planning a house for construction?
- 8) Match the following
  - a) Easy chair - entertainment
  - b) Teapoy - placing articles and music system
  - c) Table and chair - relaxation
  - d) Radio and television - necessary hospitality to guests
  - e) Built in cupboard - studying

## Part C

Answer shortly

(10 marks each)

- 1) Why is a house considered as important for mankind?
- 2) How is a living room positioned in a house?
- 3) What are the points to be considered while constructing a bed room in a house 4)  
Write the important points followed while constructing a kitchen in a house.

## Part D

Answer in detail

(20 marks each)

- 1) Write in detail the factors to be considered during site selection for the construction of a house.
- 2) Write the principles of organizing a house. Describe them.
- 3) List the names of the rooms that comprise a house. Write about any four of them in detail.
- 4) What are the types of residential houses? Explain them in detail.

Answers

- 1) c 2) b 3) d 4) d 5) d 6) d 7) c 8) a 9) c 10) a

# **UNIT - III**

## **WATER SUPPLY ENGINEERING**

### **3.1 INTRODUCTION**

Next to air, the other important requirement for human life to exist is water. It is the nature's free gift to the human race. It is essential for life, health and sanitation. It is the principal raw material for food production and for many other uses outside the home and on the farm.

Man can live without food for about two months. But he can hardly survive for three or four days without water. Thus water can be considered as the most important raw material of civilization. Therefore it becomes necessary to maintain, conserve and use the water resources very carefully. The sources of water, quality of water, treatment and distribution of water will be discussed in this chapter.

#### **3.1.1 NEED FOR PROTECTED WATER SUPPLY**

The water collected directly from the source contains many bacterias and micro-organisms which are harmful to any living organism. If water is not made safe against disease causing germs, it may be responsible for the water borne diseases like, typhoid, cholera, dysentery etc., To safeguard the health of people, it is necessary to supply the water potable and free from various harmful impurities.

#### **3.1.2 OBJECTIVES OF PUBLIC WATER SUPPLY SCHEME**

The broad objectives of a public water supply system are

- 1) To ensure safe wholesome water to the public adequately.
- 2) There are less chances of water borne diseases to occur resulting in saving of human lives.
- 3) The industries which require pure water for their working are saved from the expenditure of installing their own water purification plant.
- 4) The installation and maintenance of the water supply scheme grant opportunities of employment to the local people.
- 5) The sanitation of the area is considerably improved by the adequate water supply.
- 6) A good water supply scheme promotes trade and industries.

#### **3.1.3 PLANNING OF WATER SUPPLY SCHEME**

Before a water supply project is taken up, a scheme is drawn and different aspects of the entire scheme are carefully viewed from different angles. Following points have to be considered while planning any water supply scheme.

## **1. Population**

From the available census data, the present population should be estimated accurately. Then probable population after three or four decades is decided by any suitable method. Based on the future expansion, the water requirement for the scheme is decided.

## **2. Per capita water demand**

The demand of water depends on various uses such as domestic, industrial etc. The per capita consumption should be decided by carefully considering all the above possible uses. The total quantity of water required for the scheme is obtained by multiplying the per capita consumption and the population.

## **3. Sources of water supply**

The success of a water supply scheme entirely depends on a good source of supply of water. The source should provide adequate and good quality of water throughout the year.

## **4. Financial aspects**

The scheme should be adjusted based on the availability of fund. Also the scheme should be as economical as possible.

## **5. Quality of water**

The quality of available water decides the line of treatment of water. The cost of the treatment depends on its quality. If the water is pure, lesser will be the cost of treatment.

## **6. Topography of the area**

The topographical map of the area to be served by the scheme should be prepared and studied in relation to low lying area, ridges, density of population etc. to ensure a simple and cheap water supply scheme.

## **7. Development of the town**

The trends of the future development of the town should be properly predicted and implemented carefully in the scheme.

### **3.1.4 WATERDEMAND**

Whenever an engineer is given the duty to design a water supply scheme for a particular section of the community, he has to first of all evaluate the amount of water available and the amount of water demanded by the public. The first study is to consider the demand and then the second requirement is to find sources to fulfill that demand. Many a times, a compromise is sought between the two and the demand is met with.



### **3.1.4.1 TYPES OF DEMANDS**

The water requirement of a community may be grouped under the following categories.

- i) Domestic use
- ii) Industrial and Commercial use
- iii) Public use
- iv) Fire demand
- v) Loss and waste

#### **i. Domestic use**

The quantity of water required for domestic purposes are drinking, cooking, bathing, washing, sanitary purposes, private uses etc. This demand depends upon the living conditions of the community. In India, on an average the domestic consumption of water under normal condition is 135 litres / capita / day as per IS : 1172-1993. This amount to about 50% of total consumption.

#### **ii. Industrial and commercial use**

This includes the water required for manufacturing plants, hotels, dairy, offices, business centres, stores, sugar refineries etc. The requirement greatly depends upon the character of the city. This amounts to 20 to 25% of the total consumption.

#### **iii. Public Use**

This includes water required for the public purposes such as washing of roads, cleaning of public sewers, fountains, swimming pools, temples etc. This amounts to about 10% of the total consumption.

#### **iv. Fire demand**

This is the quantity of water required for fire fighting purposes. The quantity of water required for the fire fighting purposes should be made easily available and always kept stored. In India, the quantity of water required for fire prevention is taken as 1 litre / capita / day which is about 5% to 10% of total consumption.

#### **v. Loss and waste**

This includes the water loss in pipeline due to various reasons like defective pipe joints, damaged meters, cracks, thefts, faulty valves and fittings. This amounts to about 15% of total consumption.

### **3.1.5 PER CAPITA DEMAND**

If Q is the total quantity of water required by a town per year in litres for the population P then,

$$\text{Per capita demand} = \frac{Q}{P \times 365} \text{ lit / day}$$

### 3.1.6 FACTORS AFFECTING THE PER CAPITA DEMAND

The following factors affect the per capita demand

- 1) Size of the city
  - 2) Class of consumer
  - 3) Climatic conditions
  - 4) Quality of water
  - 5) System of water supply
  - 6) Sewerage facilities
  - 7) Industries and Commerce
  - 8) Pressure in the distribution system
  - 9) Metering system
1. **SIZE OF CITY** : In a large city, the water demand per head may be more. Lot of water is used for maintaining clean and healthy environments.
  2. **CLASS OF CONSUMER** : People with high standard of living require more water than those belonging to the middle class and low-income groups.
  3. **CLIMATIC CONDITIONS**: Hotter climates need more water due to more bathing, air conditioning and more lawn and street sprinkling.
  4. **QUALITY OF WATER**: If the quality and taste of the supplied water is good, the consumption will be more.
  5. **SYSTEM OF WATER SUPPLY**: Water may be supplied either continuously for all the 24 hours of the day or intermittent supplies. The intermittent supplies may lead to some saving in water consumption. But the intermittent supplies will not give savings under the following two situations.
    - a) In intermittent supply system, water is generally stored by consumers in tanks, drums, utensils etc., for use during non-supply periods. This water is wasted by the customer at the time when fresh supply is restored.
    - b) People generally keep the taps open to come to know the supply time. Many a times, water goes on flowing unattended even after the supply is restored thus resulting in wastage of water.
  6. **SEWERAGE FACILITIES** : The existence of sewerage system in a locality will lead to an increase in use of water for flushing of sanitary appliances.
  7. **INDUSTRIES AND COMMERCE** : Water consumption is usually more when water is to cater for large industrial and commercial use.
  8. **PRESSURE IN THE DISTRIBUTION SYSTEM**: The consumption of water increases with increase in distribution pressure due to heavy losses and wastes.
  9. **METERING SYSTEM**: If meters are used, consumers are charged according to usage. This develops sense of economy and thereby reduce the consumption.

## **3.2 SOURCES OF WATER**

The sources from which water is obtained for water supply schemes can be classified into two types.

- 1) Surface sources
- 2) Subsurface sources

### **3.2.1 SURFACE SOURCES**

The primary source of water is rain. When rain falls on the ground a certain portion percolates into the ground and the balance portion remains on the ground as surface water

The usual forms of surface sources are as follows

- 1) Lakes and Streams
- 2) Ponds
- 3) Rivers
- 4) Storage Reservoirs
- 5) Sea

### **3.2.2 SUBSURFACE SOURCES**

These sources obtain their supply from percolation of precipitation. Ground water is comparatively safer. Ground water is free from suspended impurities and are reliable. It is due to the fact that water get strained during their passage through the porous underground strata. Ground water contains more dissolved minerals and gases. The bacterial content is usually low. In general ground water is good in quality. But they may require some treatment to improve their chemical characteristics.

#### **FORMS OF SUBSURFACE SOURCES**

- 1) Springs
- 2) Wells
- 3) Infiltration galleries
- 4) Infiltration wells

## **3.3 QUALITY OF WATER**

Absolutely pure water cannot be found in nature. Though rain water is originally pure, it loses its purity by absorbing various gases, dusts and other impurities on its fall. The part of the rain water that flows over the ground surface picks up silt, organic and inorganic impurities. The remaining part of the rain water which percolates through the ground also gathers some mineralogical, organic and inorganic matters.

### **3.3.1 IMPURITIES IN WATER AND ITS CLASSIFICATION**

The impurities present in water may be divided into the following three categories:

- 1) Physical impurities
- 2) Chemical impurities and
- 3) Bacteriological impurities

### 1. PHYSICAL IMPURITIES

They are due to the presence of inorganic substances like clay, pebbles, sand, silt, algae, fungi, bacteria etc. in water in finely divided conditions. Physical impurities give taste, odour, colour and turbidity to water.

### 2. CHEMICAL IMPURITIES

They may be either organic or inorganic. They may be present in either suspended or dissolved form. The suspended organic chemical impurities are due to the presence of vegetables or animals in water. The dissolved inorganic chemical impurities are caused by the melting of minerals and gases in water.

### 3. BACTERIOLOGICAL IMPURITIES

The bacteriological impurities are caused in water by the presence of bacteria. The bacterias may be harmful or harmless. Harmless bacterias are called non-pathogens. They are not dangerous. Pathogens are dangerous and are mainly responsible for water borne diseases.

#### 3.3.2 WATER QUALITY ANALYSIS

In order to ascertain the quality of water, it is subjected to various tests. These tests can be divided into the following categories.

- 1) Physical tests
- 2) Chemical tests
- 3) Bacteriological tests

**The list of tests and properties / impurities determined in the test are tabulated below:**

Tests	Properties / Impurities
1) Physical Tests	i) Turbidity ii) Colour iii) Taste iv) Odour
2) Chemical tests	i) Total Solids ii) Hardness iii) pH value iv) Chloride v) Residual chlorine vi) Iron and Manganese
3) Bacteriological tests	1) Total Count of Bacteria 2) E-coli test

## 1 PHYSICAL TESTS

### i. Turbidity

Turbidity is caused by the presence of finely divided, suspended and colloidal matters like clay, loam and sand or micro organisms. It is more during floods. It is a measure of its resistance to the passage of light through it. It is expressed in parts per million (ppm) or milligram per litre (mg/l). The standard unit of turbidity is the turbidity produced by one part of finely divided silica (Fuller's earth) in a million parts of distilled water. For drinking water, the permissible turbidity is 5 to 10 ppm.

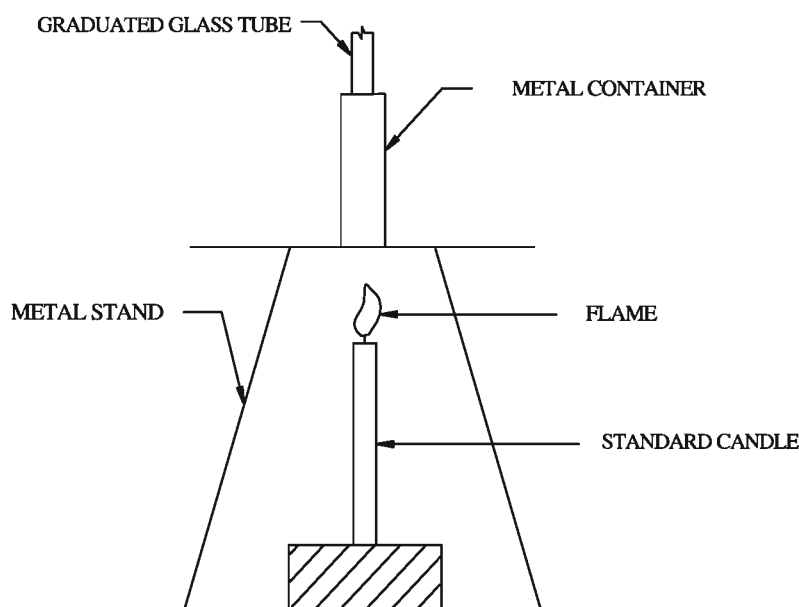

**Fig. 3.1 JACKSON TURBIDITY METER**

The instrument shown in Fig 3.1 is Jackson's turbidimeter which can measure turbidities above 100 ppm. It consists of a metal stand, standard candle, metal container and a graduated glass tube.

A small portion of the water sample is taken in the tube and a glowing candle flame is viewed from top through the water in the tube. More and more water is gradually added until the flame image disappears. When this happens, the reading in the tube corresponding to the level of water directly gives the turbidity in ppm.

### ii. Colour

Dissolved organic matter from decaying vegetation or some inorganic materials such as coloured soils etc. may impart colour to the water. The test for true colour should be taken up only after removing all the suspended particles by centrifuging. The sample is then compared for colour with standard colour solutions or colour discs.

The unit of colour is the colour produced by one milligram of platinum cobalt in a litre of distilled water. The colour of public water supply should not exceed 20 mg / s.

### **iii. Taste and Odour**

The dissolved organic materials or the inorganic salts, or the dissolved gases may impart tastes and odours to the water. Taste and odour are generally combined together. Tastes may be sweet, bitter, salty, brackish and irritating. Odours may be fishy, earthy, grassy, mouldy, vegetable etc. The odour is identified by using osmoscope.

## **2. CHEMICAL TESTS**

### **i. Total Solids**

The total solids consist of dissolved and suspended solids. The total solids present in water can be determined by evaporating a sample of water and weighing the dry residue left. The suspended solids can be found by filtering water sample and weighing the residue left on the filter paper. The difference between the total solids and suspended solids will give the dissolved solids. The amount of total solids should preferably be less than 500 ppm and should never exceed 1000 ppm in any case.

### **ii. Hardness**

It is the property of water which prevents the lathering of soap. It is due to the presence of bi carbonates, sulphates and chlorides of calcium and magnesium. The hardness due to the presence of bicarbonates of calcium and magnesium is termed as temporary hardness or carbonate hardness. It can be removed either by boiling or by adding lime to water. The permanent hardness or non carbonate hardness is due to sulphates and chlorides of calcium and magnesium. It cannot be removed by boiling. It requires water softening.

### **iii. pH value**

The pH value of water indicates the logarithm of reciprocal of hydrogen ion concentration present in water. It is thus an indicator of the acidity or alkalinity of water. The pure water consists of positively charged ( $H^+$ ) Hydrogen ions combined equally with negatively charged Hydroxyl or ( $OH^-$ ) ions. The water is said to be acidic when positively charged  $H^+$  ions are excess than  $OH^-$  ions and the pH value ranges from 0 to 7. The water is said to be alkaline when  $OH^-$  ion exceeds  $H^+$  ion and the pH value ranges between 7 to 14.

### **iv. Chloride**

Chlorides are generally present in water in the form of Sodium Chloride Eg. Common Salt. The amount of chloride present in the water is determined by titrating the sample of water with Silver Nitrate solution taking Potassium Chromate as buffer. The end point is the appearance of red colour. The permissible limit of chloride for drinking water is 250 ppm.

### **v. Residual chlorine**

The free chlorine which remains as residue in treated water after the contact period is called residual chlorine. It can be determined by two methods.

- a) Starch Iodide method
- b) Orthotolidine Arsenite method

## **vi. Iron and Manganese**

They usually occur together. They should be less than 0.3 ppm in potable water. They produce rust spots on fabrics (clothes) and plumbing fixtures. They are determined by chlorometric principle. Iron is determined by phenolphthaline method. Manganese is determined by persulphate method. They impart reddish brown colour to water.

## **3. BACTERIOLOGICAL TESTS**

The following tests are normally done for bacteriological examination of water.

- i) Total count test
- ii) E-Coli test

### **i. Total count test**

In this test, bacterias are cultivated on specially prepared culture medium of agar containing nutrients for bacteria. The diluted sample is incubated at 20°C for 48 hours or 37°C for 24 hours. The bacterias grow and multiply and form colonies or clusters. The bacterias thus formed are counted and the results are computed for 1 cc. For potable water, the total count should not exceed 100 per cc.

### **ii. E-Coli test**

It is also called as B-Coli test. In this method, the sample of water is filtered through a sterilized membrane containing microscopic pores of size 5 to 10 millimicron to retain bacterias. The membrane with retained bacterias is incubated for 20 hours at 37°C along with nutrients. After this period, the membrane is taken out and the colonies of bacterias are counted by means of microscope. This method is called membrane filter technique.

## **3.4 TREATMENT OF WATER**

### **3.4.1 A LAYOUT OF WATER TREATMENT PLANT**

- 1) Source
- 2) Screening chamber
- 3) Plain sedimentation tank
- 4) Sedimentation aided with coagulation
- 5) Filtration unit
- 6) Water softening unit
- 7) Disinfection unit
- 8) Pumping and Storage unit
- 9) Distribution system

### **3.4.2 SCREENING**

Water, when derived from the surface sources may contain floating matters. Most of the big and visible objects such as trees, branches, sticks, vegetation, fishes, dead and floating animals etc. can be removed by screening. Screens may be of two types

- 1) Coarse screens
- 2) Fine screens

### **3.4.3. SEDIMENTATION**

It is the process of causing heavier solid particles in suspension both organic and inorganic, to settle by retaining the water in a huge tank called sedimentation tank.

#### **3.4.3.1 THEORY OF SEDIMENTATION**

The particles heavier than water tend to settle down due to the force of gravity. Impurities in water are held in suspension due to the turbulence of the moving water. When this turbulence is checked and the velocity of flow is reduced, the suspended particles tend to settle down at the bottom of the tank. The settling velocity depends upon

- 1) The horizontal velocity of flow.
- 2) The shape and size of the particle.
- 3) The specific gravity of the particle.
- 4) The temperature of water .

#### **3.4.3.2 TYPES OF SEDIMENTATION**

There are two types of sedimentation. They are

- 1) Plain sedimentation
- 2) Sedimentation with coagulation.

##### **1. Plain sedimentation**

In this, the raw water is retained for sometime in a huge tank for the suspended particles to settle down by the action of gravity.

##### **2. Sedimentation with coagulation**

In this, certain chemical compound called coagulant is added to water to assist sedimentation. The coagulant react with impurities in water and convert them into settleable solids.

#### **3.4.3.3 CLASSIFICATION OF SEDIMENTATION TANKS**

Sedimentation tanks are classified into two types according to nature of working. They are

- a) Intermittent flow type
- b) Continuous flow type



### **a. Intermittent type**

In this type, raw water is allowed to rest for some time in the tank. During that time the suspended particles settle down at the bottom. The clear water is drawn off and the deposits cleaned. Then the tank is refilled and the action continues. Hence these tanks are called intermittent type settling tanks.

### **b. Continuous flow type**

In this type, raw water is allowed to flow through the tank continuously with a very small uniform velocity. Within the detention time the suspended particles settle at the bottom before they reach the exit. This type is mostly used in all the modern treatment units. It requires less space and is economical. The inlets and outlets are so designed that they cause least disturbance to the flowing water in the tank.

## **3.4.4 FILTRATION**

Filtration is the process of passing the water through the filter beds. Filtration removes colour, odour, turbidity and pathogenic bacteria from water.

### **3.4.4.1 THEORY OF FILTRATION**

The filtration involves the following actions

- 1) Mechanical straining
- 2) Sedimentation and absorption
- 3) Biological metabolism
- 4) Electrolytic changes

#### **1. MECHANICAL STRAINING**

The filtering media contains a number of voids between the sand grains. When water is passed through these voids, the suspended particles which are bigger in size than the voids are retained on the surface of the sand bed. This action is called mechanical straining which removes the suspended particles.

#### **2. SEDIMENTATION AND ABSORPTION**

The voids between the sand grains act as minute sedimentation basins. The colloidal matter arrested in these voids is a gelatinous mass. Therefore it attracts other finer particles by absorption.

#### **3. BIOLOGICAL METABOLISM**

It is the growth and life process of living cells. When bacteria are caught in the voids of sand grains the surface layer gets coated with a biological film. This film contains large colonies of living bacteria. They feed on the organic impurities present in water. They convert such impurities into simple harmless compounds by a complex biochemical action. This results in the filtration of water.

#### **4. ELECTROLYTIC CHANGES**

The sand particles of filter media and ionized matter in water carry electrical charges of opposite nature. Hence they attract each other and neutralize the charge of each other. This results in the alteration of chemical characteristics of water.

### 3.4.4.2 TYPES OF FILTERS

The filters are mainly classified as

- 1) Slow sand filters
- 2) Rapid sand filters
- 3) Pressure filters

The terms rapid and pressure represent high rate of filtration and slow indicate low rate of filtration.

#### 1. Slow sand filter

A slow sand filter is a water tight tank of 2.5 to 3.5m in depth. It has a sand bed of 1 to 1.5m thick, supported by a 0.3 to 0.75m thick layer of graded gravel or broken stone (25 to 50mm size, of 0.30 to 0.60m thick) laid in layers. Beneath this, an under-drainage system consisting of open-jointed drains is laid over a concrete bed sloping towards a central longitudinal drain. The filtration is effected by gravity.

The rate of filtration is 100 to 200 l/m<sup>2</sup>/hour. Its bacterial efficiency is 98 to 99%. The filter bed is cleaned by scraping. This type of filter is unsuitable for waters having turbidity more than 50 ppm.

#### Construction

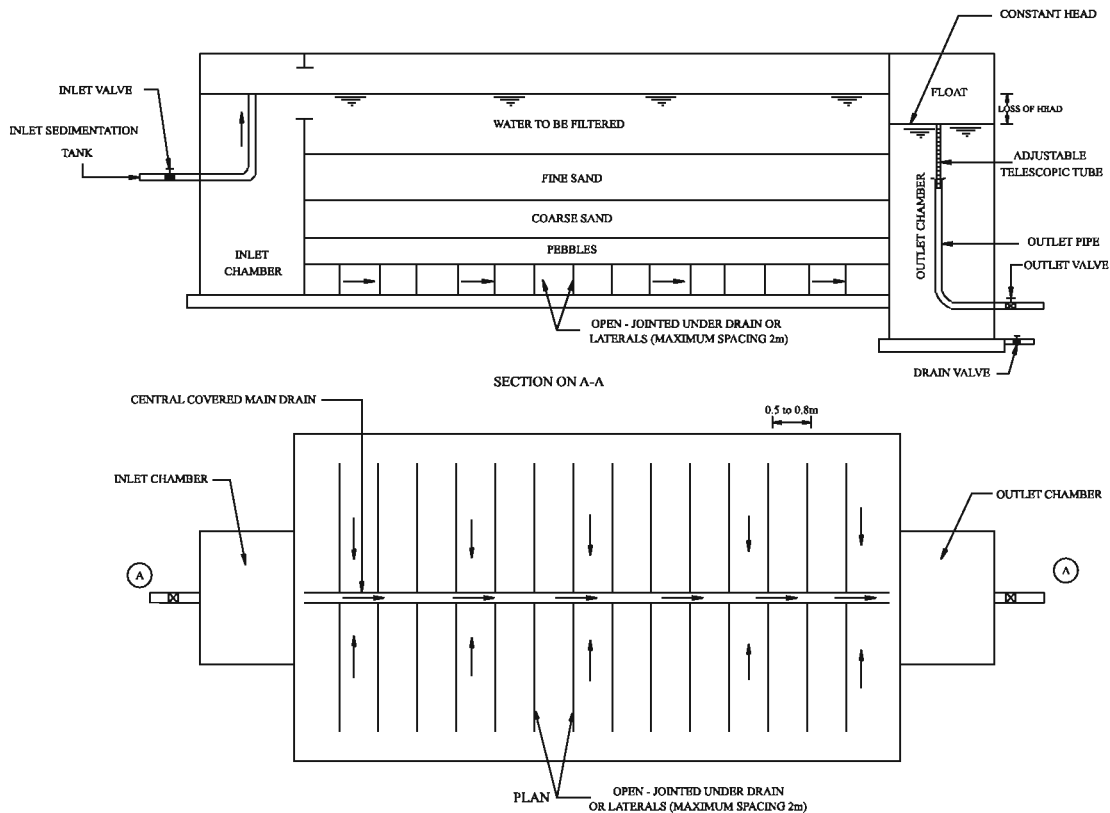

Fig. 3.2 PLAN & LONGITUDINAL SECTION OF A SLOW SAND FILTER

A typical plan and longitudinal section of a slow sand filter is shown in fig 3.2 It consists of the following essential parts.

- i) Enclosure tank
- ii) Filter media.
- iii) Base material
- iv) Under-drainage system
- v) Inlet and outlet arrangement
- vi) Other appurtenances.

**i. Enclosure tank**

It consists of an open water tight rectangular tank, built of masonry or concrete. The sides and floor are coated with water proof material. The bed slope is about 1 in 200 to 1 in 100 towards the central main drain. The depth may be 2.5 to 3.5 m.

**ii. Filter media**

It consists of sand layers of 0.6 to 1 m thick, laid over gravel support. The effective size of sand is 0.25 to 0.35 mm and uniformity coefficient is 2 to 3. The top 150 mm layer of this sand is generally finer. The finer the sand used, purer will be the water obtained.

**iii. Base material**

It consists of 150 mm thick layers of graded gravel of 0.30 to 0.75m thick or 25 to 50 mm size broken stone, 0.3 to 0.6 m thick. It supports the sand bed. The coarsest gravel is used in the bottom most layer and the finest in the top most layer.

Top most layer	-	150 mm thick	-	3 mm to 6 mm size
Intermediate layers	-	150 mm thick	-	6 mm to 20 mm size
	-	150 mm thick	-	20 mm to 40 mm size
Bottom most layer	-	150 mm thick	-	40 mm to 65 mm size

**iv. Under-drainage system**

The gravel support is laid on the top of an under-drainage system. The under-drainage system is laid on a concrete floor sloping towards the central covered main drain. The lateral drains are open-jointed pipes or porous pipes placed at a maximum spacing of 2 m. Their edges are placed upto a distance of 0.5 to 0.8 m from the wall.

**v. Inlet and outlet arrangements**

An inlet chamber is constructed to receive the discharge from the plain sedimentation tank. The inlet pipe is carried vertically in the centre of the filter. The mouth of the inlet pipe is in flush with the water level. A filtered water outlet well is also constructed on the outlet side to collect the filtered water. To maintain a constant discharge through the filter, an adjustable telescopic pipe is used.

## **vi. Other appurtenances**

Certain other appurtenances are also provided for the efficient working of the filter. Vertical air pipes passing through the layers of sand may be provided to help in proper functioning of filter media. Similarly, arrangements are made to control the depth of water above the sand layer (1 to 1.5 m). A meter to measure the flow and a gauge to measure loss of head are also provided.

## **Working**

The treated water from the sedimentation tank is allowed into the inlet chamber. It is uniformly distributed over the sand bed to a depth of 1 to 1.5 m without any disturbance. The water percolates through the filter media and gets filtered. Now the water enters the base material and comes out as filtered water. It gets collected in the laterals and discharged into the central main covered drain from where it is finally discharged into the filtered water well. The standard rate of filtration (100 to 200 litres/m<sup>2</sup>/hour) is continued until the difference between the water levels in the filter and the outlet chamber is slightly less than the depth of water above the sand or the loss of head reaches 0.7 to 1.2 m.

## **Cleaning**

During working of the filter if the loss of head reaches the permissible limit, the working is stopped. About 20 to 30 mm sand is scraped from the top of the filter bed. The top surface is finally raked, roughened, cleaned and washed with pure water till the sand depth reduces to 0.4 m or so. Then more clean sand is added to have a minimum sand depth of about 0.45 m. The interval of cleaning may vary from 1 to 3 months.

After every cleaning, the initial filling is done by admitting filtered water from the bottom till it rises about 0.8 m above the sand. Then the fresh water is allowed to enter from the top.

## **2. Rapid sand filters**

In rapid sand filters, the yield is about 30 times the yield given by slow sand filters for the same filter area. This is achieved by increasing the size of sand. They are also known as mechanical sand filters.

A rapid sand filter is an open water tight chamber, 3 to 3.5 m deep. It has coarse sand filter media, 0.6 to 0.75 m thick, laid on 0.45 m thick graded gravel. The under-drainage system is supported by concrete floor. The under-drainage system consists manifold with strainers mounted on top and laterals. Laterals have perforations on sides. The filtration is effected by gravity.

The rate of filtration is about 3000 to 6000 litres/m<sup>2</sup>/hour. Its bacterial efficiency is 80 to 90%. It removes turbidity upto 30 to 40 ppm.

**Construction** A typical longitudinal section of a rapid sand filter is shown in Fig.3.3 The following are its essential parts.

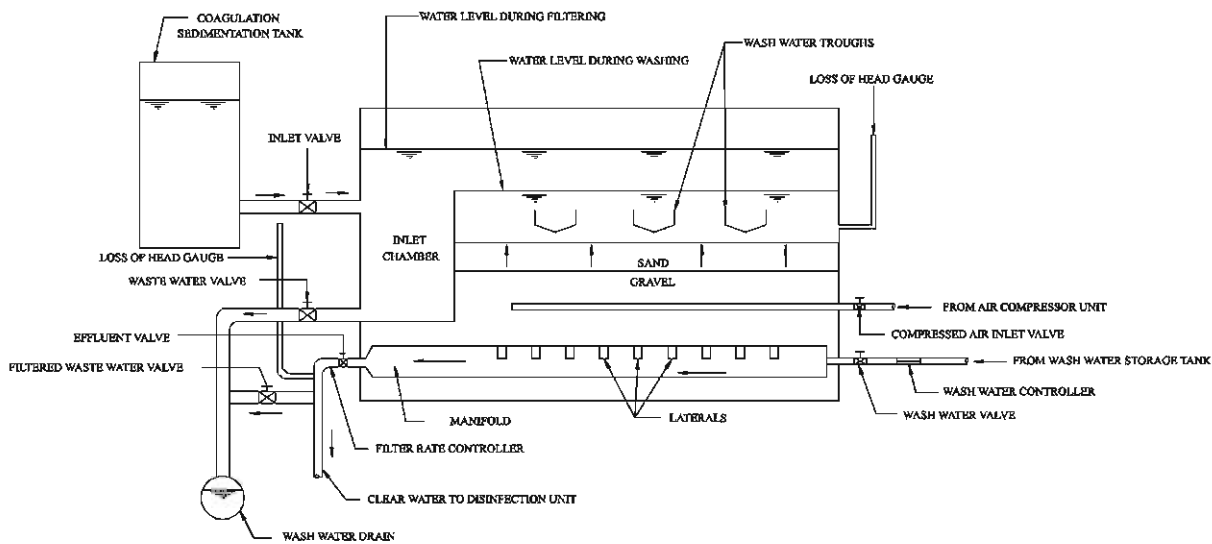

**Fig. 3.3 RAPID SAND FILTER**

- i) Enclosure tank.
- ii) Filter media
- iii) Base material
- iv) Under-drainage system
- v) Appurtenances

**i. Enclosure tank**

It is an open watertight tank built either of masonry or concrete. The sides and floor are coated with waterproof material. It is about 2.5 to 3.5 m deep, 3.5 to 6 m wide and 6 to 9 m long. The units are arranged in series. The surface area may be 10 to 80 m<sup>2</sup>.

**ii. Filter media**

It consists of sand layers of 0.6 to 0.9 m thick, supported over graded gravel layer. The effective size is 0.35 to 0.60 mm and uniformity coefficient is 1.2 to 1.7. Finer sand is placed at the top and coarser variety at the bottom.

**iii. Base material**

Durable, hard, strong and clean graded gravel free from clay, dust, silt and vegetable matter is used as base material. It is placed on the top of an under-drainage system to a thickness of 0.45 to 0.9 m.

Top most layer	-	150 mm thick	-	3 mm to 6 mm size
Intermediate layers	-	150 mm thick	-	6 mm to 12 mm size
	-	150 mm thick	-	12 mm to 20 mm size
Bottom most layer	-	150 mm thick	-	20 mm to 40 mm size

#### **iv. Under drainage system**

It consists of a cast iron central longitudinal conduit or manifold with laterals branching off at right angles to it as shown in fig 3.3. Laterals are smaller diameter pipes fixed at 150 to 300 mm centres. They are provided with 6 to 12 mm diameter holes at an angle of 30° to the vertical at 75 to 200 mm centres.

#### **v. Appurtenances**

The following are the major appurtenances of a rapid sand gravity filter.

- i) Air compressor
- ii) Rate controller
- iii) Wash water troughs

#### **Action during filtration**

Inlet valve is opened and water from coagulated sedimentation tank is allowed to enter the filter. Effluent valve is opened to carry filtered water to clear water reservoir. During this time all other valves remain closed. Only inlet and effluent valves are opened.

#### **Action during backwashing**

Backwashing is done when the loss of head reaches the maximum permissible limit of 2.5 to 3.5m. The filter is drained out leaving a very small depth of water standing above the filter bed. Now the compressed air is sent under pressure through the under drainage system for about 2 to 3 minutes. This agitates the mass of water. The agitated water loosens the dirt from the surface of sand grains. Then an upward flow of water from a high level tank is sent through the bed. This causes the sand bed to expand, agitate the sand grains and wash off the surface deposits. The deposits are carried by wash water troughs and disposed through wash water drains. During backwashing the valve positions are that the inlet valve and effluent valve are closed, and the valves of wash water trough and wash waters drains remains open.

## **3.5 DISINFECTION OF WATER**

**Disinfection** of water is the process of removal of pathogenic bacteria from water by chemical or other means.

The chemicals used for killing disease producing bacterias are known as **disinfectants**.

### **3.5.1 NECESSITY OF DISINFECTION**

Even the filtered water may contain some harmful impurities such as disease producing bacterias, dissolved inorganic salts, colour, odour, taste, iron and manganese.

The bacterially contaminated water will spread various diseases and their epidemics causing disaster to public life. Hence disinfection is most essential. Further disinfection not only kills the existing bacterias from water, but also prevents its contamination during its transit from the treatment plant to place of its consumption.

### **3.5.2 METHODS OF DISINFECTION**

Chlorine has been universally recognized as the most ideal disinfectant in treatment of water on a large scale. Hence chlorination refers to the treatment of water with chlorine for disinfection.

### **3.5.3 SOME EASY METHODS OF DISINFECTION OF WATER.**

- 1) Boiling
- 2) Excess lime treatment
- 3) Iodine and bromine treatment
- 4) Ozone treatment
- 5) Potassium permanganate treatment
- 6) Silver treatment
- 7) Ultra-violet rays treatment.

The most commonly adopted two minor methods of disinfection of water are discussed below.

#### **1. BOILING**

Continuous boiling of water for a long time above a certain temperature kills the bacteria. It is the most effective method of disinfection. It is highly impracticable to boil water on a large scale for public water supplies. However during water borne epidemics, it is advisable to boil water before consumption.

#### **2. EXCESS LIME TREATMENT**

Addition of excess lime to water removes salts and also kills the bacterias. Use of excess lime increases the pH value of water. When the pH of water rises to about 9.5 or so, 99.93 to 100% bacterias are removed even from highly polluted waters.

After disinfection, by adopting some suitable method the excess lime is removed from water before its public supply. Further this method cannot protect water from recontamination.

### **3.5.4 CHLORINATION**

Chlorine is a very powerful and universally adopted disinfectant in public water supplies. The treatment by chlorination is cheap and reliable. It produces desired effects and lasts long. It is also cheap, easy to measure and handle. Chlorination is the treatment of water with chlorine or its compounds for the disinfection of water.

Chlorination not only disinfects, but also removes colour, odour, unpleasant taste and prevents the growth of weeds in water.

## 3.6 WATER SOFTENING

Water softening is the process of reduction or removal of **hardness** from water.

### 3.6.1 PURPOSE OF WATER SOFTENING

Water softening is done to achieve the following objectives.

- 1) To reduce soap consumption.
- 2) To reduce corrosion and incrustation of pipes and fittings.
- 3) To improve the taste of food preparations.
- 4) To reduce scaling in boilers.
- 5) To minimise its interference in dyeing systems.

Hardness of potable water is 5 to 8 degrees. Hardness less than 5 degrees is tasteless and above 8 degrees produces undesirable effects. One degree of hardness = 14.25 ppm.

### 3.6.2 HARDNESS OF WATER

It is the characteristic which prevents the lathering of soap. It is caused by the presence of certain salts of calcium and magnesium dissolved in water.

#### TYPES OF HARDNESS

- 1) Temporary hardness or Carbonate hardness.
- 2) Permanent hardness or Non-carbonate hardness.

Temporary hardness is due to the presence of bicarbonates of calcium and magnesium. Permanent hardness is caused by the presence of sulphates and chlorides of calcium and magnesium.

#### 1. Removal of temporary hardness

The temporary hardness can be removed by boiling or by adding lime which is called as lime process. Lime process is otherwise known as clark process.

The principle involved in this process is the neutralization of carbon-di-oxide with milk of lime.

#### 2. Removal of permanent hardness

The permanent hardness can be removed by special methods of water softening. Any of the following methods can be adopted.

- i) Lime - soda process.
- ii) Zeolite process or Base exchange process.
- iii) Demineralisation.



## **3.7 DISTRIBUTION SYSTEM OF WATER**

Distribution system of water is the supply of safe and wholesome water to all parts of the area served at adequate pressure and quantity.

### **3.7.1 REQUIREMENTS OF GOOD DISTRIBUTION SYSTEM**

A good distribution system should satisfy the following general requirements

- 1) It should be capable of supplying water in adequate quantities and pressure at all points of the area served.
- 2) It should meet the demands of water supply for fire-fighting purposes.
- 3) It should be thoroughly reliable.
- 4) It should be economical in its design, layout and construction.
- 5) It should be easy and simple to operate and repair.
- 6) It should be safe against any future pollution of water.
- 7) It should be water-tight so as to keep the “losses due to leakage” to the minimum.
- 8) It should be safe and not cause the failure of the pipe lines by bursting etc.

### **3.7.2 DIFFERENT SYSTEMS OF SUPPLYING WATER**

Depending upon the situation, the water supply system may be classified as below:

- 1) System of conveyance and distribution.
- 2) System of water supply.
- 3) System of distribution layout.

#### **1. Systems of Conveyance and Distribution**

Depending upon the levels of water source and that of the area served, topography of the area served and other local conditions and considerations, following methods are adopted.

- i) Gravity system
- ii) Pumping system
- iii) Combined pumping and gravity system.

#### **2. Systems of Water Supply**

Based on the frequency of water supply, the following water supply systems may be followed.

- i) Continuous system
- ii) Intermittent system.

#### **3. Systems of Distribution Layout**

There are four systems of layout of distribution pipes.

- i) Dead end or tree end system.
- ii) Grid-iron system or interlaced system or reticulation system.
- iii) Circular or ring system.
- iv) Radial system.



**Answer in one or two words**

**(1 mark each)**

- 1) Write the two classifications of sources of water
- 2) Write any two forms of underground sources of water.
- 3) What are the impurities present in water?
- 4) What is the permissible limit of chloride in drinking water?
- 5) Mention the tests conducted for bacteriological examination of water.
- 6) State the classification of sedimentation tanks.
- 7) What are the types of filters used for filtration of water?
- 8) What do you mean by water softening?
- 9) What are the two types of hardness of water?
- 10) Write the types of conveyance and distribution system of water supply.

**PART-B**

**Answer in one or two sentences**

**(4 marks each)**

- 1) Write any five importances of public water supply scheme.
- 2) Explain about fire demand.
- 3) What do you know about the quality of water?
- 4) Discuss about Chlorination.
- 5) What is meant by hardness?
- 6) Explain E- coli test .
- 7) What do you mean by screening? Explain.
- 8) What are the types of filtration ?
- 9) What is the need for water softening?
- 10) Mention the types of distribution layout for water.

## PART-C

### Answer shortly

(10 marks each)

- 1) Discuss the need for protected water supply and importance of public water supply scheme.
- 2) Explain: Planning of water supply scheme.
- 3) What is meant by demand of water supply and explain their types.
- 4) What is meant by disinfection of water and explain it in detail.
- 5) What are the requirements of good distribution system and explain it elaborately.

## PART-D

### Answer in detail

(20 marks each)

- 1) What is meant by per capita demand of water and explain the factors affecting the per capita demand.
- 2) State the three types of tests conducted for water quality analysis. Explain them in detail.
- 3) Explain the construction and function of slow sand filter with sketch.
- 4) Explain the construction and working of Rapid sand filter with sketch.

### Answers

1)c 2)d 3)a 4)c 5) c 6)a 7) c 8)b 9) b 10) a 11) a 12) b 13) a

# UNIT - IV

## SANITARY ENGINEERING

### 4.1 INTRODUCTION

Water used by the community is disposed as wastewater (sewage). This chapter deals with the study of the collection, conveyance, treatment, disposal of sewage and construction of sewers. Also water and air pollution are discussed.

#### 4.1.1 PURPOSE OF SANITATION

The main purpose of sanitation is to maintain such environments which will not affect the public health. The purposes are :

- 1) To maintain a safe environment that will not affect the public in general
- 2) Proper disposal of human excreta and wastewater
- 3) To avoid pollution of soil and water
- 4) Reuse and recycling of waste and waste water
- 5) To use the fertilizing elements of sewage for growing crops through sewage farming
- 6) To adopt individual septic tank for houses if common sewage treatment plant is not possible.

#### 4.1.2 DEFINITION OF TERMS

- 1) REFUSE: In sanitary engineering, it is the waste matter which is rejected or left as worthless. It includes garbage, sewage, sullage, storm water and subsoil water.
- 2) GARBAGE: It is the dry refuse and includes decayed fruits, grass, leaves, paper pieces, sweepings, vegetables, etc.
- 3) SEWAGE: It is the liquid waste from the community. It includes sullage, discharge from latrines, urinals etc., industrial wastes and storm water.
- 4) SULLAGE: It is the liquid waste from bath rooms, kitchens, wash basins etc. It is merely waste water and does not create bad smell.
- 5) SEWER: It is the underground conduit or drain through which sewage is conveyed.
- 6) SEWERAGE: The entire process of collecting and carrying sewage by water carriage system through sewers is known as sewerage.
- 7) INVERT: It is the lowermost level or surface of a sewer.

#### 4.1.3 COLLECTION AND CONVEYANCE OF REFUSE:

Following are the two methods which are mainly adopted for the collection and conveyance of the refuse.

- 1) Dry or Conservancy system
- 2) Water carriage system

##### 1. DRY OR CONSERVANCY SYSTEM:

Dry or Conservancy System is a very old system which is still being adopted in very small town and villages where proper sewer system is not available. A collection vehicle is utilised to collect human excreta and other such waste from each and every house and taken outside the locality or town and dumped in an open pit and buried. Later they get converted as manure.

Sullage and bathroom waste water are carried in open drains to nearby river or stream and disposed of in them.

The garbages from each house and from the street are collected in dust bins placed along the road side and frequently removed through bullock carts or trucks to a place outside the town and disposed of by burning or burying. Dried leaves, plants, wooden logs, broken furniture, paper and paper product are burnt immediately. Fruits, vegetables, fresh green plants etc., will be separated, dried and then burnt.

## **2. WATER CARRIAGE SYSTEM:**

In water carriage system human excreta, urine etc, are mixed and diluted in sufficient quantity of water and taken through sewers from the collection point to the point of treatment. It is treated in treatment plants until it doesn't cause any harm to human health and then disposed of safely in river or stream. Since water carries the sewage, it is called as water carriage system. This method is considered to be the best method world wide.

### **ADVANTAGES OF WATER CARRIAGE SYSTEM**

- 1) It is hygienic, since the sewage is carried in covered conduits
- 2) No labour is required
- 3) Maintenance cost is low
- 4) No difficulty in collecting and conveying sewage even in multistoried buildings
- 5) Modern methods of treatment can be given in this system

### **DISADVANTAGES OF WATER CARRIAGE SYSTEM**

- 1) Needs large quantity of water
- 2) Initial cost of construction is high.

#### **4.1.4 SYSTEMS OF SEWERAGE**

Following are the three systems of sewerage :

- a) Separate system
  - b) Combined system
  - c) Partially separate system
- a. **SEPARATE SYSTEM:** In this system, two sets of separate sewers are laid, one for carrying sewage and the other for carrying storm water. The sewage is carried to the treatment plant and the storm water is directly discharged into the natural outlet in the form of river or stream.
  - b. **COMBINED SYSTEM:** In this system, only one sewer is laid and it carries both, sewage and storm water. The sewage and storm water are carried to the sewage treatment plant.
  - c. **PARTIALLY SEPARATE SYSTEM :** In this system, the arrangement is made to permit early washings by rain into the sewers carrying sewage. But when the quantity of storm water exceeds a particular limit, it is collected and conveyed in open drains to the natural river or stream.

#### 4.1.5 QUANTITY OF SEWAGE

In order to find out a suitable section for the sewer it is necessary to determine the quantity of sewage that will flow through the sewer. Generally sewage denotes domestic and industrial wastes. The quantity of sewage depends on the population and the quantity of water utilised. The sewage is categorized into two types.

- 1) Dry weather flow
- 2) Storm water

**1. DRY WEATHER FLOW:** During dry weather i.e, summer season without rain, the total quantity of sewage that flows through the sewer line is called as “dry weather flow”.

##### **FACTORS AFFECTING THE DRY WEATHER FLOW :**

- i) Infiltration and exfiltration of ground water
- ii) Location of Industries
- iii) Population
- iv) Rate of water supply

**2. STORM WATER:** During rainfall, some quantity of rain water evaporates, some quantity infiltrates into ground and the remaining flows as storm water.. The quantity of storm water is affected by various factors such as :

- i) Intensity of rainfall
- ii) Characteristics of catchment area
- iii) Duration of storm, etc.

#### 4.1.6 CONSTRUCTION OF SEWERS

In connection with the construction of sewers, the following topics will be discussed.

- 1) Shape of sewers
- 2) Gradient of sewers
- 3) Laying of sewers
- 4) Testing of sewers
- 5) Ventilation of sewers
- 6) Cleaning of sewers

##### **1. SHAPE OF SEWERS:**

The efficiency of the flow depends on the cross-section. Usually circular sewers are adopted. In the case of large variation in the sewage flow the sewer shapes are also modified.

The sewer sections are broadly classified into :

- i) Circular sewer sections
- ii) Non-circular sewer sections

### i. CIRCULAR SEWER SECTIONS

The circular sections are easy to manufacture or construct and handle. They are best suited for diameter upto 1.5m. They are very much useful in a separate system. The circular sections possess excellent hydraulic properties.(Fig 4.1)

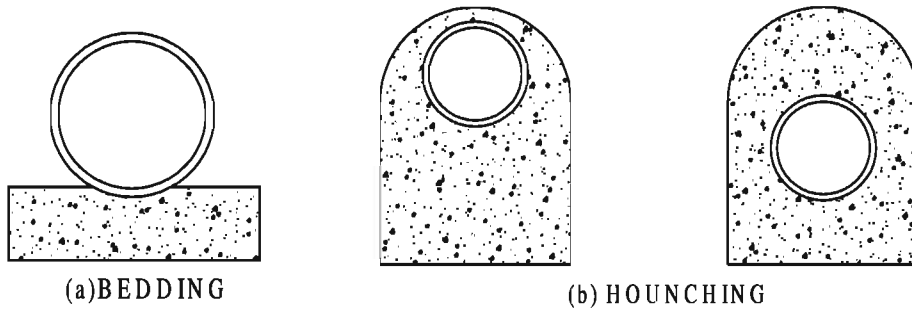

Fig. 4.1 CIRCULAR SEWER SECTIONS

### ii. NON-CIRCULAR SEWER SECTIONS

Following are the non-circular shapes which are commonly used for sewers (Fig 4.2).

- 1) Basket handle section
- 2) Egg shaped section
- 3) Horse shoe section.
- 4) Parabolic section
- 5) Rectangular or box type section
- 6) Semi-circular section
- 7) Semi elliptical section.

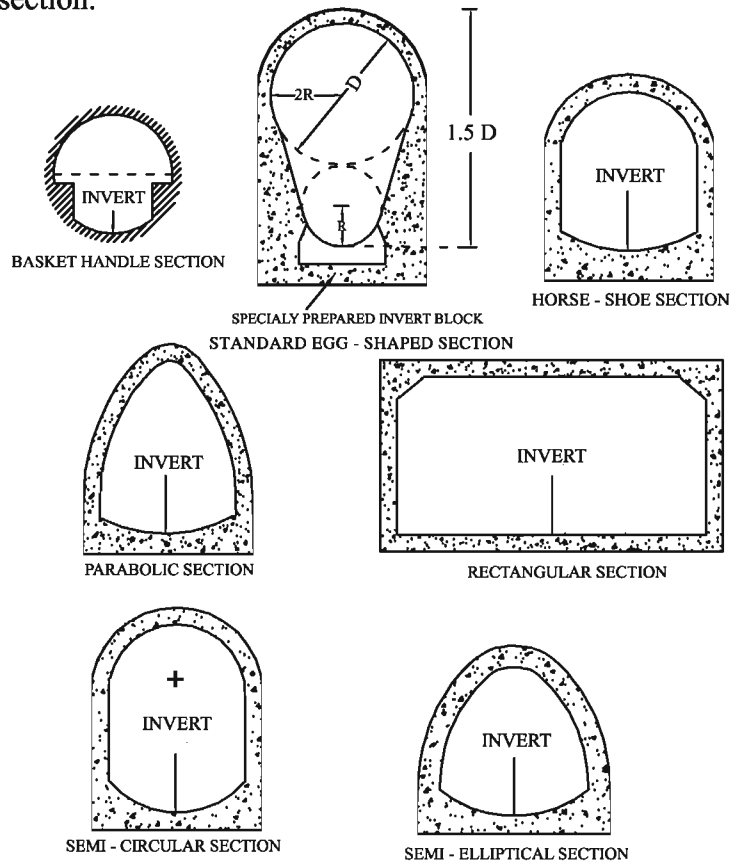

Fig. 4.2 NON - CIRCULAR SEWER SECTIONS



**2. GRADIENT OF SEWERS:** The discharge of sewage through domestic drain should be continuous but it is intermittent. If the quantity of sewage is less, the solid matter may be accumulated in the sewer. This accumulation of solids may lead to blocking of sewer drains. To overcome this difficulty, the sewer pipes should be laid with sufficient gradient to ensure smooth gravity flow.

The National Building Organisation (N.B.O) has suggested the following gradients :

Pipe Diameter (cm)	Gradient
100	1 in 60
150	1 in 100
225	1 in 120

**MINIMUM AND MAXIMUM VELOCITIES IN SEWERS:** The flow velocities in the sewers should be such that there should be no deposition of solid matter and the pipe materials should not get scoured out. A certain minimum velocity has to be maintained to avoid silting and clogging in the sewers. Such a minimum velocity is known as self cleaning velocity. To keep the sewers free from any trouble, this velocity should be developed at least once in a day, preferably twice in a day. For normal sewage, self cleaning velocity is 0.9 m/sec. When the floating matter mixed with sewage flows with high speed they tend to erode the sewer pipe line.

The maximum permissible velocity at which no scouring (wear & tear) action takes place is known as non-scouring velocity. Non-scouring velocity mainly depends on the material used in the construction of sewers.

The following table shows the non-scouring velocities for common sewer materials.

S.No.	Material of the sewer	Non- scouring velocity (m/sec)
1	Earthen Channels	0.6 to 1.2
2	Brick	1.5 to 2.5
3	Cement concrete	2.5 to 3.0
4	Stoneware	3.0 to 4.5

### 3. LAYING OF SEWER LINES:

In the sewerage system setting out of an alignment is generally started from the tail end on the downstream and proceeded upwards. The following procedure is adopted for the laying of a new sewer.

**SETTING OF ALIGNMENT:** Borings or trial holes are dug along the proposed sewer line to know the nature of the soil.

The exact position of manholes are located at the site with the help of sewerage plan and working drawings.

The centre line of sewer between two manholes is marked on the surface of the ground. The length between two successive manholes must be straight.

Along the centre line, pegs are driven at convenient distances of every 7.5m or 15m at curves and at 30m along straight lines, There are two methods for laying.

i. **FIRST METHOD:** In this method a line parallel to the centre line of sewer is marked on one side. This is known as offset line. Usually it is marked at a distance of 'D' which is about one half the trench width plus 600mm as shown in Fig.4.3 The other side is used to dump the excavated material. The offset line helps in locating the centre line of the sewers when excavation is being carried out.

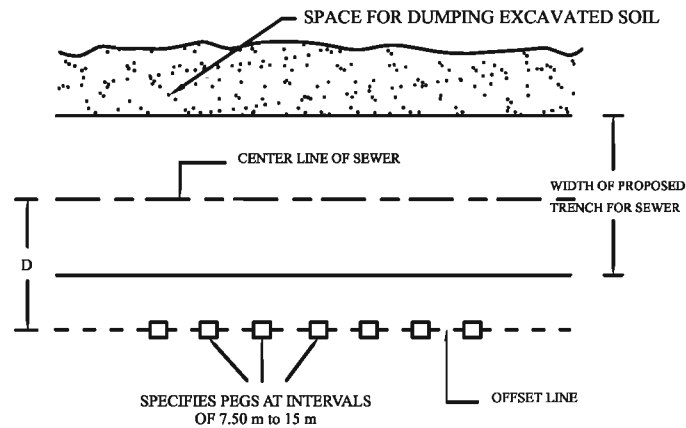

**Fig. 4.3 OFFSET LINE**

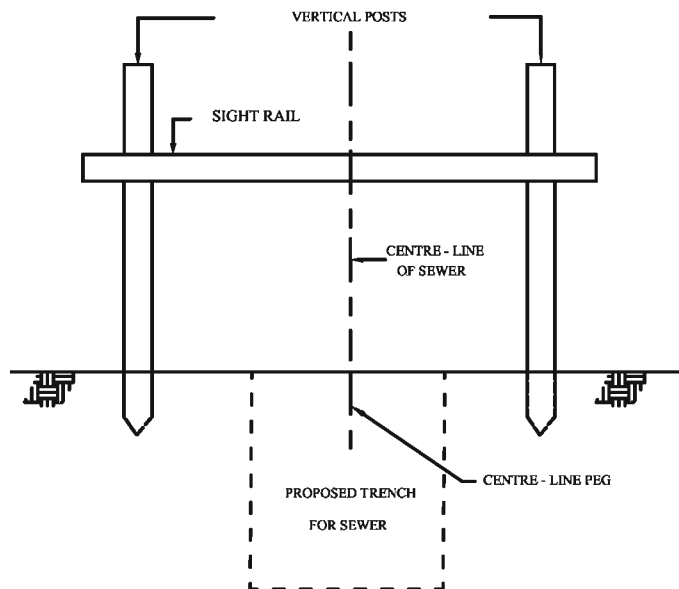
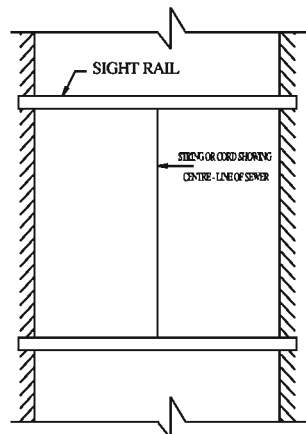

**Fig. 4.4 SIGHT RAIL**

**ii. SECOND METHOD:** In this method, two vertical posts are driven into the ground at a known distance from the centre line of the peg on either side (Fig 4.4). The horizontal members known as sight rails are held in position with vertical posts. The height of sight rails depends upon the R.L of invert or concrete bedding. The line joining the top of the sight rails will give the gradient of the sewer to be laid in the trench. The slope of the line joining the top of the sight rails is transferred below the trench with the help of boning rod.

When the levels and the grades for the excavation of trench are decided then the actual excavation work is started and the bottom of the trench is correctly dressed. The proposed gradient is given with the help of boning rod.

When the sewers are laid, it is a general practice to place its socket in the direction of flow. After laying the sewer pipes, the levels are checked once using a levelling instrument (Fig 4.5).



**Fig. 4.5 PLAN OF TRENCH FOR SEWER**

#### **4. TESTING OF SEWERS**

The sewer line laid should be tested before it is put to use. The following tests are to be done :

- i) WATER TIGHTNESS TEST    ii) OBSTRUCTION TEST    iii) STRAIGHTNESS TEST

After completing these tests, sewage is conveyed through the pipe.

- i. **WATER TIGHTNESS TEST:** After constructing the sewer, some period of time should be given for the joint to become hard and strong. The test for water tightness of joints is carried out in between two manholes. If the sewer is made up of stoneware or concrete, then it should be tested whether it is capable of withstanding 1.5m of pressure head (Fig 4.6).

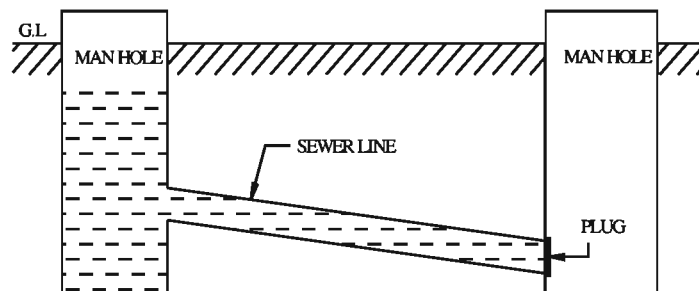

**Fig. 4.6 TESTING OF SEWER LINE**

The lower end of sewer line at manhole is provided with plug by using a rubber bag with canvas cover and is fitted so that it is tightly closed. In the manhole at the upper end of sewer line, water is filled in through a funnel fitted in a rubber cock and it is allowed to flow continuously for 10 minutes through the sewer line. The depth of water in the upper end manhole is maintained at 1.5m. If the water level gets reduced then it indicates that there is some leakage in the line. The sewer line is watched by moving along the trench and the joints which have sweated are repaired. If any leakage is detected then the corresponding pipe is replaced.

- ii. **OBSTRUCTION TEST:** In this test, a smooth ball of diameter 13mm less than the diameter of sewer line is inserted at the high end of the sewer or drain. In the absence of any obstructions, like cement mortar, gunny cloth, bit of ropes, etc., the ball shall roll down in the invert of the pipe and emerge at the lower end.
- iii. **STRAIGHTNESS TEST:** In this test, a mirror is placed at one end of the sewer line and a lamp is placed at the other end. If the pipe line is straight, the full section of the sewer is observed in the light. Otherwise this would be apparent. The mirror will also indicate any obstruction in the sewer barrel.

## **5. VENTILATION OF SEWERS**

Need for ventilation of sewers :

- 1) To avoid concentration of nuisance causing unpleasant odours to the public
- 2) To avoid the accumulation of explosive and poisonous gases like methane, sulphate, hydrogen and vapours
- 3) To avoid airlock
- 4) To relieve air pressures above or below atmospheric, when a branch sewer is connected to a main sewer or when the sizes of sewer pipes changes.

### **METHODS OF VENTILATION**

- 1) Proper construction of sewers
- 2) Proper design of sewers
- 3) Providing manholes with gratings for the circulation of free air in sewer line.
- 4) Providing ventilating columns or shafts
- 5) Providing manholes with chemicals
- 6) Providing unobstructed outlets.

## **6. CLEANING OF SEWERS**

Following are the 3 important causes which make it necessary to clean the sewers :

- 1) Breakage of sewers
- 2) Clogging due to silt deposit, grease and dirt, roots of vegetation, etc.,
- 3) Foul odours.

## METHODS OF CLEANING SEWERS

- i) Cleaning and flushing
- ii) Cleaning of catchpits etc.

### **i. CLEANING AND FLUSHING:**

- a) The cleaning of small sewers is effected by flushing. For this purpose, automatic flushing tanks are sometimes installed on the sewer line. It cleans the sewer automatically by washing. A pipe hose with nozzle, bamboo sticks may also be inserted in the sewer and water under pressure may be discharged through the nozzle to clean the sewer.
- b) For clearing medium size sewers scrapping instruments are used. Flexible rods called cane rodding is dragged in the sewer to and fro from the manholes. The cane rodding is done until the obstruction is removed.
- c) The cleaning of large sewers is done manually. The man enters the sewers through manholes and scraps the sides of sewer by hand. The scrapped material is removed through manholes.
- d) If the block is very worst, hollow balls are passed inside the sewer pipe and it hits the block and the block is removed.

**ii. CLEANING OF CATCH PITS :** A tank like structure called catchpit constructed between the sewer line is used to collect storm water. They are cleaned after every storm. Usually the catch pit contains debris, silt, sand etc. Often the top cover is opened and they are removed.

### **4.1.7 SEWERAPPURTENANCES**

Sewer appurtenances are the additional structures constructed at suitable intervals along the sewer line for efficient working and maintenance of sewerage system.

Following are the important sewer appurtenances :

- 1) Manhole
- 2) Drop Manhole
- 3) Lamphole
- 4) Catch basins
- 5) Clean-outs
- 6) Flushing tanks
- 7) Inlets
- 8) Grease and oil traps
- 9) Inverted syphons
- 10) Storm water regulators

1. **MANHOLE:** A manhole is defined as the construction made to connect the ground level with the hole or opening made in the sewer line so that man can easily, conveniently and safely enter through it and carryout the usual maintenance operations. It is constructed where two or more sewer lines intersect or where there is a change in gradient or when there is a change in the size of the sewer pipe. It provides ventilation also.
2. **DROP MANHOLES:** The term drop manhole is used to indicate the manhole on sewer line which is constructed to provide a connection between the high level branch sewers (0.5 to 0.6m above main sewer) to the low level main sewer with a minimum amount of disturbance. The edge of branch sewer is constructed nearer to the main sewer line and thus it helps the man to go inside for working in it.
3. **LAMP HOLES:** A lamphole is an opening or hole constructed in a sewer between two manholes for the purpose of lowering a lamp inside it. It helps in the inspection of sewerline and to determine any blockages. Water can be flushed through it if there is any blockage. Also it provides ventilation.
4. **CATCH BASINS:**A catch basin or catch pit is a structure in the form of a chamber which is provided along the sewer line to admit clear rain water free from silt, grit, debris, etc. into the combined sewer.
5. **CLEAN OUTS:** A clean-out is an inclined pipe for cleaning sewer pipe by inserting iron rod when it is not possible to flush it with water. One end is connected to the underground sewer and the other end is brought upto the ground level and is covered. It is generally provided at the upper ends of lateral sewers.
6. **FLUSHING TANKS:** The flushing tank is a device or arrangement used to store water and then to throw the water into the sewer for the purpose of flushing it with self cleaning velocity.
7. **INLET:** An inlet is an opening through which storm water and surface wash flowing along the streets are admitted and conveyed to the storm water sewers or combined sewer by means of pipe. These are constructed at 30 m to 60 m intervals. These inlets, catch and drain strom water quickly to sewers. Hence stagnation of rainwater in roads is prevented. There are two types of inlets :
  - i) Horizontal inlet.
  - ii) Vertical inlet.
8. **GREASE AND OIL TRAPS:** If grease and oil are not separated then they will be deposited inside the sewer. The capacity of sewer will be reduced due to adhesion of floating matter with grease and oil. Hence traps or chambers are placed on the sewer line to exclude grease and oil from sewage before it enters the sewer.
9. **INVERTED SYPHONS:** Inverted siphons are ordinary pipes running under pressure and constructed lower than the adjacent sewer sections. They are constructed for conveying the sewage under streams, railway line, rivers and other such obstructions. They are also called depressed sewers.

10. **STORM WATER REGULATOR:** The structures used to divert a portion of the flow of sewage from combined sewers are called storm regulators. Storm regulators come into operation when the discharge exceeds a certain limit. Since some quantity of sewage is separated and diverted to river and ponds the load on pumps and treatment units gets reduced.

## **4.2 QUALITY OF SEWAGE**

The quality of sewage plays an important role in the design of sewer and construction of various treatment units. Also the quality of sewage decides the method of treatment to be adopted.

### **4.2.1 PROPERTIES OF SEWAGE**

- 1) Physical characteristics
- 2) Chemical characteristics
- 3) Biological characteristics

#### **1. PHYSICAL CHARACTERISTICS**

The sewage has the following physical characteristics.

- i) Odour            ii) Colour        iii) Turbidity    iv) Temperature

- i) **ODOUR:** Fresh sewage is odourless. When it becomes stale, it has offensive odour by hydrogen sulphide and other sulphur compounds.
- ii) **COLOUR:** If the colour of the sewage is yellowish, grey or light brown, it indicates fresh sewage. If the colour of the sewage is black or dark, it indicates septic or stale sewage.
- iii) **TURBIDITY:** The turbidity of the sewage depends directly on the quantity of solid matters present in suspension state. Sewage is normally turbid.
- iv) **TEMPERATURE:** The normal temperature of sewage is slightly higher than the water supplied for various uses. When the sewage flows in closed conduits, its temperature further rises. This affects the biological activity, solubility of gases and viscosity of sewage.

#### **2. CHEMICAL CHARACTERISTICS**

These indicate the state of sewage decomposition, its strength and type of treatment required. Fresh sewage is alkaline and good for bacterial action. Stale or septic sewage is acidic and is difficult to treat efficiently. The chemical characteristics depend upon the substances contained in the sewage. The substances are complex organic, derived from urine, human excreta etc., and inorganic chemicals.

#### **3. BIOLOGICAL CHARACTERISTICS**

It is necessary to know the biological characteristics of sewage due to the presence of living organisms like algae, protozoa and fungus. Most of the bacteria do not cause harm. Moreover they help in decomposing the organic wastes naturally. Because of this the cost of treatment also gets reduced.

## 4.3 TREATMENT OF SEWAGE

To protect the environment, the contaminants present in waste water or sewage must be removed by giving suitable treatment. Treatment process depends on the nature of wastes present in waste water.

### 4.3.1 FLOW DIAGRAM OF SEWAGE TREATMENT SYSTEM

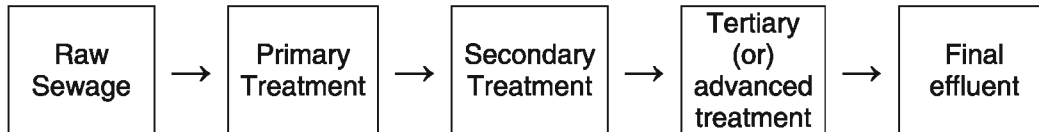

1. **PRIMARY TREATMENT:** Among the treatment methods this is the primary stage of treatment. In this treatment, sewage is passed through various screens. Solid materials like paper, cloth, wooden material, rubber, cork and floating material etc., are stopped through these screens. This is fixed prior to the grit chamber.
2. **SECONDARY TREATMENT :** This includes filtration and activated sludge process.
3. **TERTIARY TREATMENT :** This includes the disinfection and removal of other heavy metals like nitrogen and phosphorous etc.,

#### 1. PRIMARY TREATMENT

- i. **SCREENING:** The very first unit operation carried out in waste water treatment plant is screening. In this, sewage is passed through different screens. A screen is a device with openings, generally of uniform size. It is used to retain the large particles of floating or suspended matters like paper, clothes, wooden pieces, rubber, cork, etc., present in the waste water. Screens should preferably be placed before the grit chamber.
- ii. **SKIMMING TANKS:** A chamber constructed across the flow of sewage to detain floating matters such as oil, grease, fats, soap etc is known as skimming tank.
- iii. **GRIT CHAMBER:** The purpose of providing the grit chamber in the sewage treatment process is to remove inorganic matter such as gravel, grit, sand, etc. that has a nominal diameter of 0.2mm and more. To achieve this purpose, the velocity of flow in grit chamber is decreased to such an extent that the heavier inorganic materials settle down by gravity.
- iv. **SEDIMENTATION TANKS:** Screens and grit chamber remove suspended particles only to a certain extent. Very fine suspended organic matters could be removed only in sedimentation tanks. These suspended particles though have a specific gravity value greater than that of water, still do not settle down because of the movement of waste water. At the same time if the waste water is made still, these particles settle down. When waste water is allowed into sedimentation tanks with very less velocity, these particles settle down as sludge which is later removed.

According to the location it can be classified into two types :

- i) Primary clarifiers - they are located just after the grit chambers
- ii) Secondary clarifiers - they are located after secondary treatment units



## **2. SECONDARY TREATMENT**

In the primary treatment process, all the settleable particles of inorganic nature are removed from the sewage. Some portion of organic matters present in the sewage is removed by primary treatment. But the major portion of organic matters can be removed by secondary treatment that includes filtration and activated sludge process.

The finer organic matters which are not settled in the primary treatment are filtered and removed in the secondary treatment by filters.

a) **FILTERS:** Filters which are commonly employed in the secondary treatment of sewage are of the following four types.

- i) Contact beds
- ii) Intermittent sand filters
- iii) Trickling filters
- iv) Miscellaneous filters.

b) **ACTIVATED SLUDGE PROCESS:** 'Activated sludge' is a sludge obtained from the primary treatment process and which will have high concentration of active micro organisms. When activated sludge is mixed for certain hours with raw or partly treated sewage, in the presence of oxygen, aerobic action takes place and the organic matters get oxidized. This process is called aeration. Suspended and colloidal matters coagulate and they form a readily settleable precipitate. The remaining clear waste water is separated out.

## **3. TERTIARY TREATMENT**

Nitrogen and phosphorous which are not removed in the secondary treatment are removed by the tertiary treatment.

This includes disinfection and removal of heavy metals.

- a) **DISINFECTION:** It removes the pathogenic bacteria by chlorination process.
- b) **REMOVAL OF HEAVY METALS:** If the sewage contains heavy metals like nitrogen and phosphorus due to industrial waste it can be removed by suitable treatments.

## **4.4 SEPTIC TANKS**

Sewage from isolated buildings, institutions, hotels, hospitals, etc. are easily disposed by providing septic tanks.

### **4.4.1 PRINCIPLE AND WORKING OF A SEPTIC TANK**

Septic tank is like a horizontal continuous flow plain sedimentation tank. The sewage moves very slowly. The flow is continuous from the inlet to the outlet. During the detention period, the solids settle down in the tank as sludge. The lighter solids such as grease, fat, etc. rise to the surface as scum. The baffle walls prevent the scum from leaving the tank with the effluent. Waste in the form of scum and the waste in the form of sludge can be retained for so many months. The solids are attacked by the anaerobic bacteria and fungi. They are broken down into simpler chemical compounds.

This is the first stage of purification called anaerobic digestion. The digested sludge from the tank is periodically removed and disposed off in a suitable manner. Generally septic tanks are constructed in the residential buildings, schools, colonies, quarters and hospitals. A portion of the solids is transformed into liquids and gases. The gases rise to the surface in the form of bubbles causing bad smell. Hence, septic tanks are covered at the top. They are provided with a high vent shaft for the escape of foul gases.

The liquid which passes out of the outlet pipe is called the effluent. It is highly odorous and rich in B.O.D. It contains highly infectious pathogenic bacteria. If it is taken to the earth directly it will create disease and unnecessary foul gases. Therefore, the effluent requires further treatment. The effluent is allowed to percolate into the subsoil either through soak pit or dispersion trench. The aerobic bacteria present in the upper layers of the soil, attack the organic matter. The organic matter is oxidised into stable end-products i.e., nitrates, carbon-dioxide and water. This stage of purification is called aerobic oxidation.

**4.4.2 CONSTRUCTION DETAILS OF SEPTIC TANK:**

The plan and section of a typical septic tank are shown in Fig.4.7.

- a) The tank is rectangular in plan and the length is kept 2 to 4 times the breadth, usually thrice.
- b) Liquid depth of 1 to 2 m and free board of 0.3 to 0.45m are provided.
- c) An elbow pipe or 'T' shaped pipe submerged to a depth of 150 to 225 mm below the liquid level is provided, as inlet pipe.
- d) "T" shaped outlet pipe is provided at a depth of 150 mm below the liquid level.
- e) Inlet baffle is placed at 1/5<sup>th</sup> the length of tank from the inlet pipe. In large tanks, T- shaped baffle walls are constructed to guide the flow and prevent short circuiting. The tank is divided

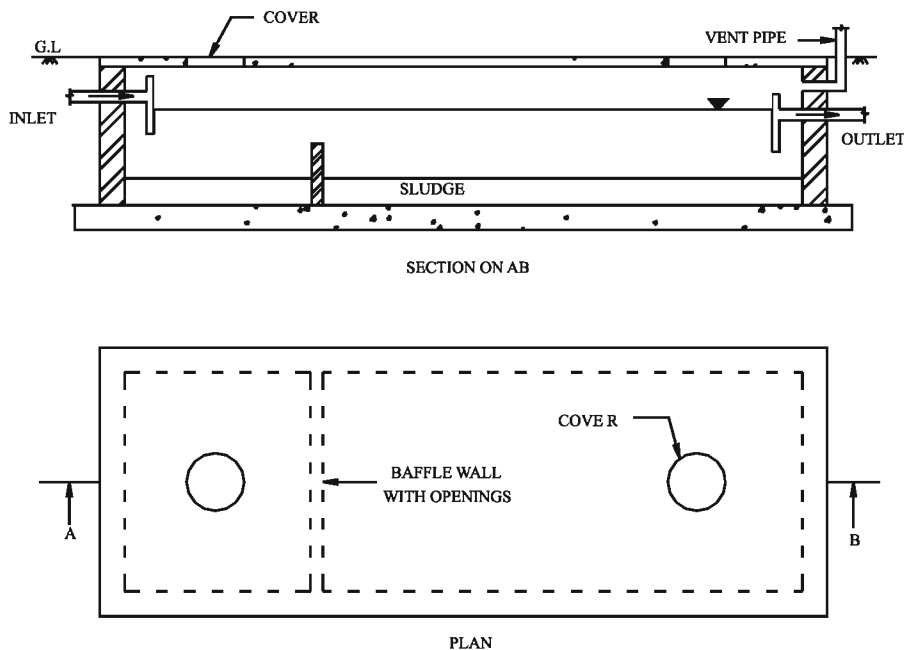

**Fig. 4.7 SEPTIC TANK**

into two compartments. The first one serves as the stilling compartment and the second one as settling compartment with a smooth exit of settled sewage.

- f) The floor is provided with all sides sloping 1 in 7 towards one point to facilitate desludging operation.
- g) Desludging pipe, 100 to 150 mm in diameter, is provided. It is controlled by a sluice valve.
- h) R.C.C. roof slab with manhole cover in each compartment is provided to permit inspection and maintenance.
- i) Ventilation is provided by a pipe 40 to 50 mm in diameter. It is taken well above the roof level. A cowl is provided at the top of the vent pipe. It prevents the birds from nesting.

#### 4.4.3 OPERATION AND MAINTENANCE

- 1) The use of soap water and disinfectants such as phenol should be avoided. They are injurious to the bacterial flora in the septic tank.
- 2) Undue accumulation of sludge reduces the capacity of septic tank and interferes with its proper working. Therefore, the contents of the septic tank should be removed periodically for every 6 months to 2 years.
- 3) Newly built septic tanks are first filled with water upto the outlet level and then seeded with digested sludge to carry out the decomposition process.

Generally the effluents from the septic tank are not directly disposed off on land, instead a soakpit is constructed below the ground level and the treated effluents are absorbed through the soakpit before being disposed.

#### 4.4.4 SOAK PIT

This is a covered circular or square pit. The effluent is allowed into it. It gets soaked or absorbed into the surrounding soil. The pit may be kept either empty or filled up with brick bats or stone aggregates (Fig.4.8). When empty, the pit is lined with brick, stone or concrete blocks with dry open joints. It is provided with atleast, 75 mm backing of coarse aggregate below the inlet level to support the lining. The depth and diameter depends upon the percolation capacity of soil.

When filled, no lining is required except for top masonry ring. Masonry lining is constructed to prevent the damage by flooding of the pit by surface run off.

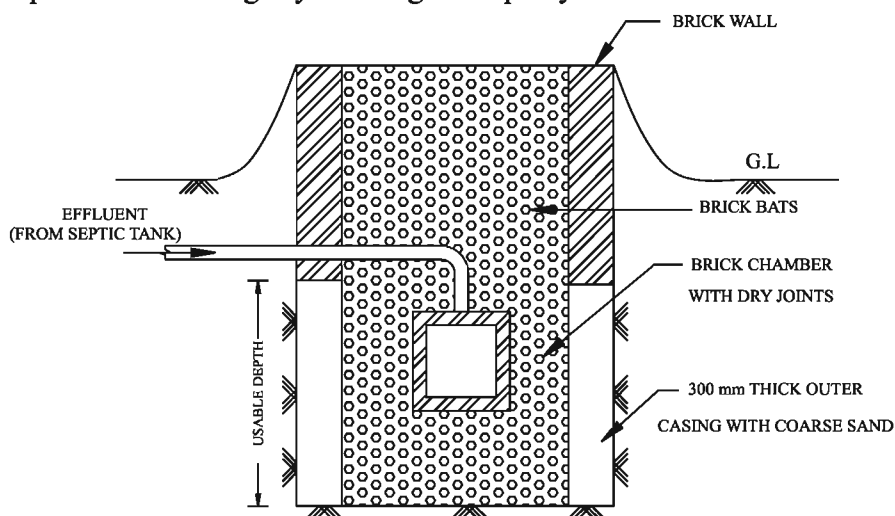

Fig. 4.8 DISPOSAL INTO SOAK PIT

## 4.5 SLUDGE DISPOSAL

### 4.5.1 SLUDGE

It is the solid matter which is retained from sewage in both primary and secondary treatment units.

### 4.5.2 QUANTITY OF SLUDGE

The quantity of sludge produced depends on several factors, viz., the character of sewage, method of treatment, temperature, method of sludge collection, etc. The quantity of sludge can be found out if the following three factors are known.

- 1) Amount of suspended solids in the incoming sewage.
- 2) Likely settlement to occur in the treatment unit and
- 3) Moisture content of the sludge.

### 4.5.3 METHODS OF SLUDGE DISPOSAL

Following are the various methods of sludge disposal :

- 1) Disposal on land
- 2) Distribution by pipe lines
- 3) Drying on dry beds
- 4) Dumping into the sea
- 5) Heat drying
- 6) Incineration
- 7) Lagooning or ponding

1. DISPOSAL ON LAND: Sludge can be disposed off on land in two ways.

- i) Ploughing
- ii) Trenching

i. PLOUGHING: In the ploughing method, the sludge is mixed with milk of lime or powdered lime and it is spread on land. When the sludge dries out, the field is ploughed. Crops can be raised on such fields.

ii. TRENCHING: In the trenching method, about 600mm deep and 900mm wide parallel trenches are made in the field at 1.5m c/c.

The trenches are filled with sludge and covered with a thin layer of excavated earth. The process is repeated by digging new trenches between the old ones and then at right angles to the previous ones.

The disposal of sludge on land is a useful method. But it requires considerable land which is not available near big cities. It could be adopted in small towns. One hectare of land is required for sludge disposed by 12,000 persons.

2. DISTRIBUTION BY PIPE LINES: In this method, the sludge is conveyed through pipe lines to the nearby farm. It is used as fertilizer by mixing with irrigation water. This method is not common in use. The success of this method depends on the following factors :

- i) Sufficient land should be available for this purpose.
  - ii) The owners of nearby land should give co-operation in receiving the sludge.
3. **DRYING ON DRY BEDS:** In this method, the sludge is dried by spreading over the drying beds. It is ideally suited for tropical country like India. The construction and working is explained below,

a. **CONSTRUCTION:** Sludge drying beds are open beds on land. They are provided with 450mm to 600mm depth. Coarse aggregate of 15mm size on the base to 12.5mm size on the top are filled upto a depth of 300mm to 450mm. For the remaining depth of 100 to 150 mm coarse gravel sand is filled. Open jointed under drain pipes with proper slope are provided below the drying bed to collect the water that comes out from the sludge. The drying beds are 15m x 30m in size. A brick wall of 1m height is constructed all around the beds.

b. **WORKING:**

Through the distribution channel, sludge is spread over a depth of 200mm to 300mm in the drying beds. Most of the sludge water is evaporated to the atmosphere. The remaining portion of the sludge that settles pass through the beds. Till all the sludge settles, new sludge should not be allowed. Generally after a period of 7 to 10 days, dried sludge is removed from the beds. Within this period 30% of the moisture evaporates and the surface of the sludge gets cracked. These sludge cakes are then removed by spades and they are dumped into a pit for further drying. They are used to rise a bund or some times as manure.

- 4. **DUMPING INTO THE SEA:** In this method, sludge is conveyed and discharged into the sea. The sludge should be taken sufficiently deep into the sea from the shore so as to avoid any chances of possible nuisance by the sludge being washed back to the shore. This method can be adopted only in case of cities situated on sea shores.
- 5. **HEAT DRYING:** In this method, the sludge is actually heated so that it may become dry. This method is commonly adopted in developed countries for producing fertilizer from the sludge obtained from activated sludge process. This method is very costly and hence it becomes impracticable.
- 6. **INCINERATION:** Where the fertilizing value of sludge is not being preserved, the sludge may be incinerated. For incineration, first the sludge is heat dried and then it is kept in furnace. There, it is ignited and burnt to ash.
- 7. **LAGOONING OR PONDING:** This is a common method of disposing sludge. A lagoon is a shallow pit formed by excavating the ground. The depth is about 0.6m to 1.2 m. At the bottom of lagoon, a 150mm thick layer of ash is placed. The under-drains consists of agricultural pipe drains of 100mm diameter. They are placed at spacing of about 3m. Embankments are formed from the excavated material. Fig 4.9 shows the section of a typical lagoon

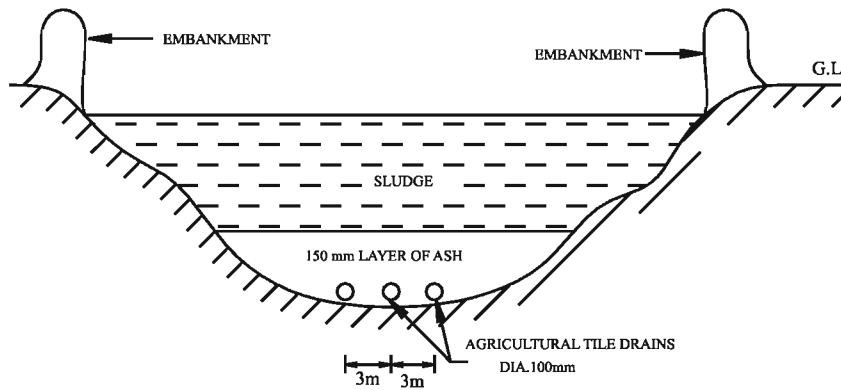

**Fig. 4.9 LAGOON**

The wet sludge is brought into the lagoon and it is left there to dry by natural process such as evaporation and percolation. The drying of sludge may require about 2 to 6 months. The dried sludge is removed from lagoons by spades and it is used as manure.

## **4.6 POLLUTION CONTROL**

Pollution is injurious to health. Therefore, pollution in any form is to be completely controlled. The aim of pollution control should be to reduce the germs of a potential pollutant. This is a multi-step process. Pollution really originates from the human activities.

### **4.6.1 WATER POLLUTION**

Water is said to be polluted when it contains infective and parasitic agents, poisonous chemical substances, industrial or other wastes or sewage.

### **4.6.2 TYPES OF WATER POLLUTION**

The following are the two main types of water pollution.

- 1) Natural pollution
- 2) Artificial or Man made pollution

#### **1. NATURAL WATER POLLUTION:**

- i) It is caused by the adverse weather conditions
- ii) Storm water bringing with it surface wastes, silt, vegetable matter, mineral matter, bacteria etc. there by polluting water.
- iii) Storage reservoir containing sand, silt and hence polluting the water.
- iv) Properties of ground surface through which water travels.
- v) Natural water pollution is occasional. Its consequential effects are little.

#### **2. ARTIFICIAL WATER POLLUTION :**

It is caused as a result of man-made activities, as below :

- i) Wastes from human habitation such as human excreta, urine, washing, kitchen waste and laundry wastes.

- ii) Wastes from industries such as grease, oil, explosives, radioactive substances, chemicals, alkalis, acids, lime, starch, highly odourous substances, coal washings, vegetable oil and soap, paper pulp, etc.
- iii) Agricultural wastes like backyard drainage, pesticides, manure, etc.
- iv) Infiltration of surrounding substances into the water distribution pipes through cracks or leaky joints.

#### **4.6.3 EFFECTS OF WATER POLLUTION**

- 1) The self-purification property of rivers is lost due to excessive organic load.
- 2) The fish and other aquatic life are destroyed due to deoxygenation.
- 3) Insanitation is caused by suspended solids.
- 4) The pathogenic bacterias enter into the water due to the presence of organic matters.
- 5) Foul smelling and unsightly sludge due to decomposed floating matter.
- 6) Sporadic outbreaks of water-borne diseases due to the consumption of polluted water by communities.
- 7) River pollution makes the water aesthetically unfit for bathing and other recreational purposes.
- 8) It is very costly and difficult to treat polluted water.

#### **4.6.4 PREVENTIVE MEASURES TO CONTROL WATER POLLUTION**

The following preventive steps may be taken to effectively control water pollution.

- 1) The people should be educated to avoid water pollution.
- 2) The industrial wastes should be treated well before discharging them into natural water bodies.
- 3) By legislative control, rules and regulations should be enforced for the prevention of water pollution.
- 4) Scientific techniques should be adopted for the environmental control of catchment areas of streams and rivers.
- 5) Forests should be conserved as they act as natural air-conditioners and control water pollution.
- 6) Discharging any type of wastes, treated or untreated, into natural water bodies should be avoided.
- 7) Affluent funds should be raised for the construction and development of treatment plants for all kinds of wastes.
- 8) The local authority and management of various industries should jointly share the responsibility to assure an effective water pollution control.

## 4.7 AIR POLLUTION

Strictly speaking, air is never pure. Air will have of foreign substances mixed in it like industrial gases, dust, etc. at all times and at all places. It is the presence of foreign matters in the outdoor atmosphere in an excessive concentration which are harmful to man or his environment. Presence of harmful elements in atmosphere which affects human health is called air pollution.

### 4.7.1 SOURCES OF AIR POLLUTION

Major sources of air pollution are

1) Natural sources

2) Manmade sources.

1. **NATURAL SOURCES:** Volcanic eruptions release poisonous gases such as Hcl and other natural gases. Forest fire introduces heavy smoke into the atmosphere. Gases from decay of animal excreta (methane) and vegetative decay and marsh gases are produced and released in the air. Desert storm also causes air pollution.  $H_2S$ , CO and  $SO_2$  are also released from sewage which pollutes the atmosphere.
2. **MANMADE SOURCES**
  - a) **INCREASE IN POPULATION:** Rapid increase of population is one of the important factor of air pollution.
  - b) **DEFORESTATION:** Plants maintain the balance of  $CO_2$  and  $O_2$  in nature. Deforestation by man for his own need has disturbed the balance of  $CO_2$  and  $O_2$  in nature.
  - c) **BURNING OF FOSSIL FUELS AND FIBRES:** About 97% of the energy we use in our homes and factories is generated by coal, oil and natural gas which are called fossil fuels. Burning these leads to the formation of gases which accumulate in the atmosphere.
  - d) **INDUSTRIES:**A large number of industries such as chemical, paper, textile, petroleum and rubber industries are responsible for air pollution.
  - e) **EMISSION FROM VEHICLES:** The exhaust from the automobiles contain gases namely carbon monoxide, carbon dioxide, oxides of nitrogen, lead, etc.
  - f) **AGRICULTURAL ACTIVITIES:** During the spray of pesticides, insecticides etc., the heavy odours are carried away by the wind and make the air polluted.
  - g) **NUCLEAR POWER PLANTS:** The radioactive rays that are emitted from nuclear power plants and the explosives etc., also pollute the atmosphere.

### 4.7.2 EFFECTS OF AIR POLLUTION ON HUMAN BEINGS

An average man inhale 22000 times a day and takes 16 kg of air each day. All the impurities inhaled do not cause harm. Depending upon the chemical nature, some of them may be harmful.

General effects on human beings :

- 1) Acute sickness and death. Chronic diseases are caused by oil refinery, grease manufacturing factory and chemical factory due to the polluted air. Head ache, irritation of eye, cough etc. are the effects.
- 2) Due to nose and throat irritation, it makes the throat to dry ultimately leading to lung cancer, running nose, asthma.



- 3) Changes in important physiological function
- 4) Because of polluted air, the ultraviolet rays from sun do not reach human beings and hence the resistive power of man is affected.
- 5) Carbon monoxide from vehicles affects human health.
- 6) Some industrial smokes may even lead to cancer.

#### **4.7.3 EFFECTS ON ANIMALS**

Animals particularly the farm animals, get poisoned when they eat contaminated vegetation. "Fluorine, arsenic and lead are the three important pollutants affecting animals.

#### **4.7.4 EFFECTS ON PLANTS (VEGETATION)**

- 1) When ozone gas gets mixed with air it affects tobacco plants. Ethilin affects flower.
- 2) When gases like hydrocarbon, flouride, sulphur oxide mixes with vegetation it affects plants.
- 3) Dropping of leaves occurs due to abscission, neu crossis.

#### **4.7.5 EFFECTS ON MATERIALS**

- 1) Corrosion of metals
- 2) Weakening of textile products like dullness of cloth and decrease in durability of cloth occurs.
- 3) Eroding of building surface
- 4) Quicker deterioration of materials.

#### **4.7.6 EFFECT ON TEMPERATURE**

Due to pollution of air, the humidity of air and its temperature changes. Since large quantity of hot smoke mixes in air, the air gets dried. Moreover it prevents sunlight during daytime leading to inadequate lighting and visibility. Therefore chances of accident on road is likely. The atmosphere remains dry and hot even during night times.

#### **4.7.7 EFFECTS ON ECONOMIC CONDITIONS**

- 1) Fuel costs increase due to ineffective burning of fuel.
- 2) Dresses and clothes get spoiled quickly and requires frequent washing.
- 3) Affects the interior and exterior of houses, leading to large maintenance cost.
- 4) Due to insufficient lighting caused by smoke, electricity is wasted.
- 5) Cracks in the rubber tyres of vehicles.

#### **4.7.8 PREVENTION AND CONTROL OF AIR POLLUTION**

The control of air pollution is ultimately an engineering problem. The World Health Organization (WHO), in its publication research into environmental pollution recommended the following procedures for the prevention and control of air pollution.

1. **CONTAINMENT:** The prevention of escape of toxic substances into the ambient air containment can be achieved by a variety of engineering methods such as enclosures, ventilation and air cleaning.

2. **REPLACEMENT:** Replacing the technological process causing air pollution by a new process that does not cause air pollution. Increased use of electricity and natural gas in place of coal is a new process of replacement. Strict laws should be enforced. Engines of vehicles should be properly tuned so that it does'nt emit too much of black smoke.
3. **POLLUTION DILUTION:** It is dilution within the self-cleaning capacity of the environment. Some air pollutants are readily diluted by vegetation. The establishment of green belts between industrial and residential areas is a method of dilution. The dilution becomes very difficult when the atmosphere is over-burdened with pollutants.

## QUESTIONS

### PART - A

**Choose the correct Answer**

**(1 mark each)**

- 1) ----- is the rain water of the locality.  
 a) Subsoil water                      b) Stormwater                      c) Sullage                      d) Sewerage
- 2) ----- of the sewage depends directly on the quantity of solid matters present in suspension state.  
 a) Colour                      b) Odour                      c) Turbidity                      d) Temperature
- 3) ----- is constructed across the flow of sewage to detain floating matters such as oil, grease, fats, soap etc.  
 a) Grit chamber                      b) Skimming tank                      c) Screening                      d) Sedimentation tank
- 4) ----- is conducted for water tightness of joints of sewers carried out in between two manholes.  
 a) Water tightness test                      b) Obstruction test                      c) Straightness test                      d) Screening test
- 5) Sewage from isolated buildings, institutions, hotels, hospitals are easily disposed by providing -----  
 a) skimming tank                      b) septic tank                      c) grit chamber                      d) incineration
- 6) It is very costly and difficult to treat ----- .  
 a) Polluted water                      b) Drainage water                      c) Subsoil water                      d) Sullage
- 7) ----- is the underground conduit or drain through which sewage is conveyed.  
 a) Sewer                      b) Invert                      c) Inlet                      d) Catchbasin
- 8) ----- are ordinary pipes running under pressure and constructed lower than the adjacent sewer sections.  
 a) Clean outs                      b) Inverted siphons                      c) Drop manhole                      d) Storm water regulators

**Answer in one or two words**

**(1 mark each)**

- 1) What is sewage?
- 2) What is sullage ?
- 3) What are the two methods adopted for collection and disposal of refuse ?
- 4) Mention the three systems of sewerage.
- 5) Mention the three tests done before a sewer line is put to use.
- 6) Mention the three properties of sewage.
- 7) Define Turbidity .
- 8) How water gets polluted?
- 9) What is the effect of air pollution on animals?
- 10) What do you mean by sewer appurtenances ?

**PART B**

**Answer in one or two sentences**

**(4 marks each)**

- 1) What are the advantages of water carriage system ?
- 2) Define Gradient of sewers .
- 3) Write the need for ventilation of sewers .
- 4) Define activated sludge process.
- 5) What is a soak pit ?

**PART C**

**Answer shortly**

**(10 marks each)**

- 1) Write about the methods of collection & disposal of refuse.
- 2) What are the preventive measures to be adopted to control water pollution?
- 3) Explain the tests conducted before a sewer line is put to use.
- 4) Write the three important factors which make it necessary to clean the sewers.
- 5) Explain about the prevention and control of air pollution.

**PART D**

**Answer in detail**

**(20 marks each)**

- 1) What are the important sewer appurtenances. Explain them?
- 2) Explain the different types of treatment of sewage?
- 3) With a neat sketch, Explain the principle and working of a septic tank?
- 4) Define Air pollution. Explain its effect on human being, plants, materials, animals?

**Answers**

- 1) b    2)c    3) b    4) a    5) b    6) b    7) a    8) b

# UNIT - V

## AESTHETICS OF A HOUSE

### 5.1 INTRODUCTION

A house which is simple and ordinarily built may be made to appear beautiful if it is constructed aesthetically. We feel proud and happy if our house looks beautiful. “A thing which is beauty is joy forever”. The requirements for good aesthetics are imagination capacity, beautiful taste and architectural feeling. The beautiful arrangement of the place where we live in and the articles in it which are required for our basic needs and suiting to our culture will lead to good aesthetics of a house.

### 5.2 IMPORTANCE OF GOOD TASTE

Each person will not have the same artistic taste. It is revealed based on the articles which a person chooses and purchases. An article liked and appreciated by a person may not be liked by other person at all. The appearance of certain things may be so pleasing to look at forever, certain appearances may be pleasing to look at for few days and few appearances for few hours only. The person's artistic or architectural taste is revealed from such things he creates.

Like jasmine and its fragrance, art and artistic feeling should always go together. The general characters of artistic things reveal certain specific characteristics. Anything that is artistically beautiful is always pleasing to look at and appreciated by everyone at all times. Therefore it is important to know the basic principles of artistic and architectural elements based on which one could appreciate and adore beauty.

### 5.3 ELEMENTS OF ART

When anything is designed, the basic elements of art its theory and the concept behind it are revealed. Design comprises of line, shape, size, direction, form, texture, space, light and colour.

1. **LINE** : A line is supposed to be a basic element of design. It could be classified as horizontal line, vertical line, straight line, inclined line and curved line. Each line depicts certain type of visual feeling. For example, horizontal line depicts stability and vertical line depicts capacity, governance and integrity (Fig 5.1).

Curved lines express a sort of femininity in viewer's mind and inclined lines express a sort of activeness, busy and unrestness. If lines are properly utilized, they express a feeling of integrity and homogeneity and if not utilized properly they could express themselves as basic elements of destruction.

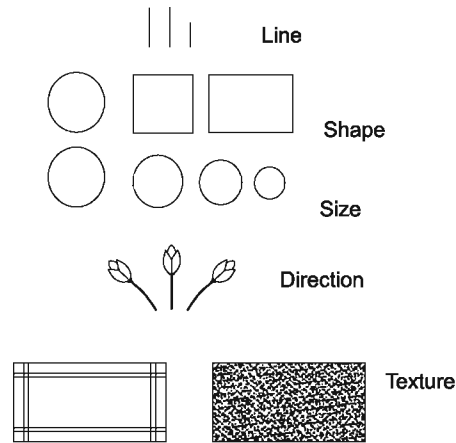

**Fig. 5.1 ELEMENTS OF ART**

Therefore the lines should be related to each other and also with the surroundings. Vertical line enhance the height of rooms of buildings.

2. **FORM :** This is an other basic element. It denotes the area, weight and quantity. Form is obtained by the combination of lines. If two horizontal lines are linked with two vertical lines, a rectangle or square is obtained. When an inclined line is joined with a vertical and horizontal line, a triangle is obtained.
3. **TEXTURE :** Texture denotes the specific exterior characteristic of an article or a furniture. The texture may vary from a smooth glossy surface to a rough surface. Any rough surface has the capacity to attract more light. The wall finishes in the interior of our houses, carpets and rugs, wood works, artistic wall hangings, porcelein or wooden articles etc exhibit changes in texture.
4. **SIZE :** Size is denoted to specify or classify articles as small, moderately small, very small or big, moderately big and very big.
5. **SHAPE :** A shape is obtained by joining lines drawn in specified directions. Square, circle, rectangle, triangle etc. are typical examples.
6. **DIRECTION :** It denotes the relative position of the lines.
7. **LIGHT :** Light always imparts enthusiasm and it activates our feelings whereas darkness will soon make us fed up with it.
8. **SPACE :** Space is required for proper arrangement and placement of the articles. By adopting suitable light colour shades for painting the wall and by avoiding construction of intermediate walls and unnecessary cross walls a feel of good adequate space availability could be induced.
9. **COLOUR :** Colour enhances the beauty of any artistic article. It expresses feelings of warmth or coolness, happiness or sadness etc. Therefore for anything to appear good and to glow, colour is required.

10. DESIGN : A good design depicts good combination of line colour and character and their proportion and arrangement. The beauty of any article lies in the selection and usage of the above. Design is classified into Structural Design and Decorative Design. Structural design denotes the shape, dimension, character, colour and form of the building. Decorative design denotes the exterior surface texture and surface enrichment that add beauty to the building. The structural design is essential for any building or article. The extent of decorative design depicts the richness of the building or article (Fig 5.2).



Fig. 5.2 GOOD DESIGN

#### 5.4 REQUIREMENTS OF A GOOD STRUCTURAL DESIGN

- 1) It should be simple and beautiful.
- 2) It should suit the requirements for which it is intended for.
- 3) It should be proportionate.
- 4) It should exhibit the character of the element of which it is made of.

#### 5.5 REQUIREMENTS OF A GOOD DECORATIVE DESIGN

- 1) The decoration should always be to a moderate extent.
- 2) Only the important places or parts of a building need to be decorated. It should enhance the strength and durability of the structure.
- 3) Decorative design should be simple and its beauty should gain respect in the viewer's mind. For this, the background of the decorative design plays an important role. Care should be taken to see that the decorations are done over the entire surface of the building component and not in specified corners or portions.
- 4) A good decorative design should not affect the utility of the component or article.

For example a decorative design and artistic carvings and protrusions on the exterior of a jug may make the jug look very attractive. But while utilizing the jug or while cleaning it certain difficulties may arise. Moreover a jug may lose its stability due to its base being narrow. Therefore even though a jug may look attractive it is not useful from utility point of view. Such a design is a wrong design. (Fig 5.3)

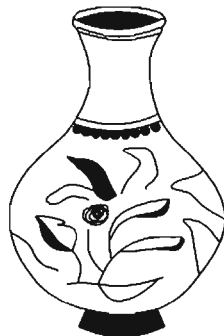

Fig. 5.3 WRONG DESIGN

## 5.6 PRINCIPLES OF DESIGN

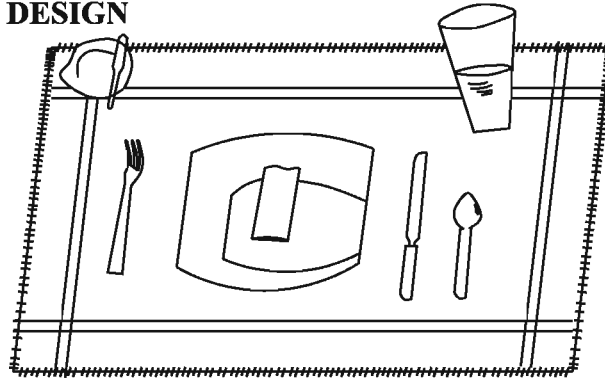

Fig. 5.4 PRINCIPLES OF DESIGN

Normally in our day to day life we come across various articles of different shapes. The shapes of all these articles have been designed keeping in view the aspect of beauty and how it looks or attracts.

A good design is decided based on the following principles.

They are,

- 1) Harmony
- 2) Balance
- 3) Proportion
- 4) Rhythm
- 5) Emphasis

1. **HARMONY:** The plan of integrity could be well expressed by harmony. It reveals the true fact for choosing and framing a particular shape. When suitable shapes are synchronized, then the idea of plan is well depicted.

For example in a dining place, if a dining table, dining chairs, plates, tumblers are placed it suits the requirements and also reveals the idea. It is called as “Harmony of ideas”. For any characterization line, shape, dimension, exterior looks, colour and idea are the primary aspects. If a dining plate is circular, then small circular cups or plates for side dish are ideally suited. Instead if square shaped cups or side dish plates are provided it will not be a good decorative design with harmony. (Fig 5.4)

2. **BALANCE:** Anything is said to be balanced if it is equally attractive on both sides with respect to a central reference line. This could be obtained by placing objects of same shape and colour on either side at equal distances from the reference.



Fig. 5.5(a) FORMAL BALANCE

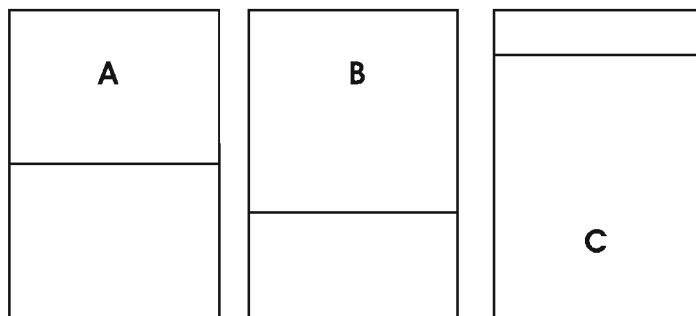

Fig. 5.5(b) INFORMAL BALANCE

**Two types of balance :**

- i) Formal balance Fig 5.5 (a)
- ii) Informal balance Fig 5.5 (b)

- i. **FORMAL BALANCE:** Formal balance is obtained by placing objects of same weight and shape at equal distances from the centre of reference on either side. Such balances will express dignity and artistic beauty. (Fig 5.5 (a))
  - ii. **INFORMAL BALANCE:** Informal balance could be obtained by placing different objects at various distances from the centre of reference when they do not have the same attractive power. for example, such a balance is similar to that of balancing a see saw in horizontal position by making a stout person sit nearer to the centre on one side and lean person to sit quite far from the centre on the otherside. If an informal balance is done with good extent of efforts it looks more dynamic and attractive than a formal balance. (Fig 5.5 (b))
3. **PROPORTION:** The compatibility of different objects in a combination or the satisfactory compatibility of different elements in a object is called proportion. When two or more objects| are combined and if they are in suitable proportion, then a sort of well being and attractiveness are obtained. For an example if a big chair is placed near a big table it looks beautiful.



**Fig. 5.6 PROPORTION**

In (Fig 5.6) shown above there are three rectangles A, B and C. The area of these three rectangles is divided into two parts. This division may or may not induce interest. The rectangle A is divided into two equal parts. This may not induce any interest. Whereas the division of rectangle C is totally different. The division of rectangle B, though not equal, reveals that there is a sweet relation between the two divided parts. Such proportioning induces interest.

4. **RHYTHM:** Rhythm is a smooth path that allows the penetration of our vision from one form or shape to another without much difficulty. This denotes the continuance of governance. If the vision of our eyes could easily develop a relation without strain between the lines, forms or shapes and colours of a component then it is called as "Rhythm". (Fig 5.7)

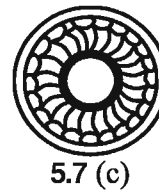
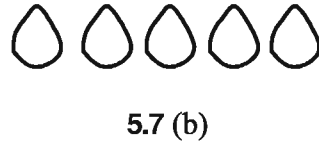

**Fig. 5.7 RHYTHM**



**Rhythm could be obtained based on the following,**

- i) Repetition
- ii) Continuous line movement
- iii) Radiation
- iv) Progression of sizes



- i. **REPETITION:** If a particular form is repeated at regular continuous intervals, then the vision of eyes get a smooth transition from one unit to another. eg: Shoe lace. Fig 5.7 (a)
- ii. **CONTINUOUS LINE MOVEMENT:** Eyes continuously and constantly move over the line of the shape of the object. Fig 5.7 (b)
- iii. **RADIATION:** For standard geometrical shapes, it forms the basis. The shape is generated by radiating lines originating from a central point. In ordinary geometrical shapes it is commonly used. Eg: Decorative brass plate, trays etc. Fig 5.7 (c)
- iv. **PROGRESSION OF SIZES:** Quick smooth vision transition and interest are developed if anything is arranged from its smaller size to its largest size. (Fig 5.8)

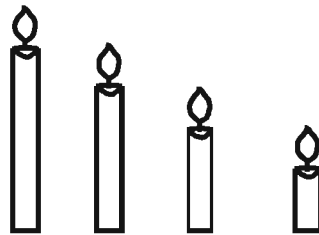

**Fig. 5.8 PROGRESSION OF SIZES**

**5. EMPHASIS:** Emphasis is obtained when some article or place is very impressive and catches the look of our eyes first on it before our eyes look at others. The method of obtaining such an attraction and impression is called emphasis. It could be obtained by the following ways. They are

- i) Arrangement of articles
- ii) Using contrast colours
- iii) Decoration
- iv) Allowing sufficient vacant space around and behind an article.
- v) Using different types of lines, forms and shapes.
- vi) Using objects of different properties.

Adopting the above in a best possible way, a good emphasis could be obtained.

## 5.7 COLOUR AND COLOUR BLENDING

Colour attracts the attention of every one. It enhances the beauty of an object which we look at and induces a refreshing feel in us. One can experience a sort of beauty in all the natural objects. The main reason for this is its colour. Each colour has got its own characteristics. Based on its characteristics it may induce happiness or irritation, beauty or depression. These effects have great influence in home environment. Based on the environment that prevails in the home, the mood or character of a person gets modified. Though one may enter the house very tired, a good colour and its blending may release his tiredness and refresh his mind.

## 5.8 CHARACTERISTICS OF COLOURS

Colours have three main characters. They are hue, value and intensity.

1. **HUE:** Hue denotes the name of the colour. For example green, red, violet etc.
2. **VALUE:** The lighter shade or darker shade of a colour is denoted by its value. The value scale shown in the (Fig 5.9) indicates that there are nine intermediate colours starting from white to black. It expresses white colour as the lightest shade colour and black colour as the darkest with all other major colours placed in between. No colour is lighter than white and no colour is darker than black.

If water or white colour is added to any particular major colour, then its lighter shade is obtained. For example rose colour is obtained from red by mixing certain quantity of white colour with red colour and similarly brown colour is obtained by mixing a little quantity of black colour with red colour.

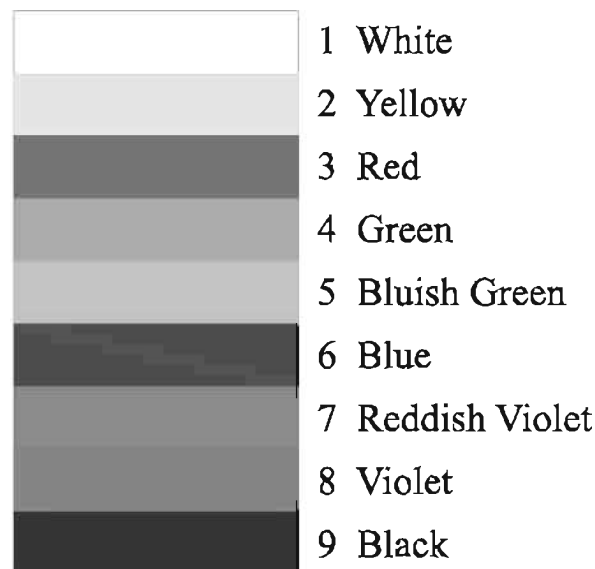
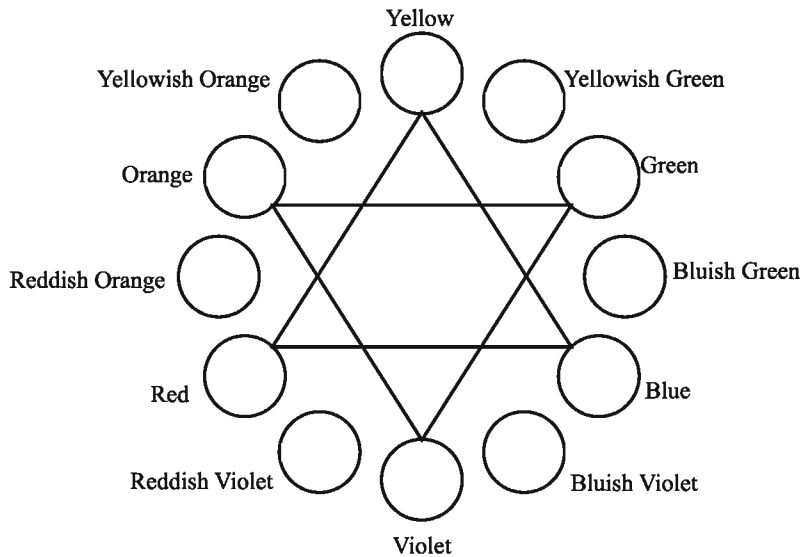

Fig. 5.9 CHARACTERISTICS OF COLOURS

3. **INTENSITY :** Intensity is used to define the brightness or dullness, strength or weakness of a colour.

## 5.9 PRANG COLOUR WHEEL

Prang colour wheel consists of Red, Blue and Yellow as the three basic or primary colours. Since the above three colours cannot be obtained by combining any of the colours, they are called as Primary colours. (Fig 5.10)



**Fig. 5.10 PRANG COLOUR WHEEL**

All other colours that could be obtained by combining equal amount of any two of the primary colours are called as secondary colours.

Yellow + Blue = Green

Blue + Red = Violet

Red + Yellow = Orange

If the primary colour is blended proportionally with a secondary colour intermediate colours are obtained. The following six colours are intermediate colours.

Yellow + Green = Yellowish green

Blue + Green = Bluish green

Blue + Violet = Bluish violet

Red + violet = Reddish violet

Red + orange = Reddish orange

Yellow + Orange = Yellowish orange

The three primary colours, three secondary colours and six intermediate colours combine to form the outer of the Prang wheel. When two secondary colours are combined, a third category colour called Tertiary colour is obtained.

For example, Green+Orange = light yellow (tertiary colour) and when two tertiary colours are combined, a fourth category in colour called Quaternary colour is obtained.

The top central portion of the Prang wheel is occupied by the yellow colour. Straight below this violet colour is present. On the rightside of the yellow colour is the blue colour and left side is the red colour. If an imaginary vertical line is drawn through the centre of the Prang wheel, the colours on the rightside of the line denote coolness and the colours like red, orange etc., on the left side of the line denote warmness. One could obtain a feel of coolness of colours like violet, blue, bluishgreen etc., on the right of the wheel. Hence such colour could be utilized in colouring the interiors of certain important rooms and ornaments of such colours could be worn to create a sense of freshness in the minds of people.

A nearby feeling and a sensation of reduction in the material size is given by hot colours. Cool colours makes a feeling of the material as if it is far away and a sensation of increase in size. Hot colours gives happyess and cool colours gives peace and silence. Light colour shows the size bigger and deep colours shows it smaller.

Black, White, Ash are neutral colours. Black colour indicates darkness and the combination of all rays of light is indicated by white colour. These are formed at the centre of Prang colour wheel.

## 5.10 COLOUR HARMONIES

When colours are combined effectively it creates happiness and satisfaction to the mind and adds beauty to the vision. This type of combination is called colour harmony. It shows the feeling of unity. Two classification of colour harmonies are i) Related colour harmony and ii) Contrasting colour harmony.

### 1. Related Colour Harmony

- a) Monochromatic Colour Harmony
- b) Analogous Colour Harmony

### 2. Contrasting Colour Harmony

- a) Complementary Colour Harmony
- b) Double Complementary Colour Harmony
- c) Split Complimentary Colour Harmony
- d) Triad

#### 1. RELATED COLOUR HARMONY :

If we use same type of colour we get related colour harmony.

##### a. MONOCHROMATIC COLOUR HARMONY

It may be called as single contrasting colour harmony. When same colour is used with several estimation we get these colour. (eg) Dark green, light green. Beautiness is obtained in contrasting colour harmony when we use materials of different property. These may be used in a hall or dress (Fig 5.11)

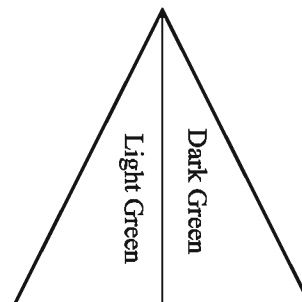

Fig. 5.11 MONOCHROMATIC COLOUR HARMONY

**b. ANALOGOUS COLOUR HARMONY**

Colours which are adjacent to each other in the Prang colour wheel have analogous colour harmony. Such a colour combination reveals a tendency of dependency. Since it is entirely different from an individual colour, it creates an interesting feel. (Fig 5.12)

For eg: i) Yellowish green, Yellow

ii) Reddish blue, Blue

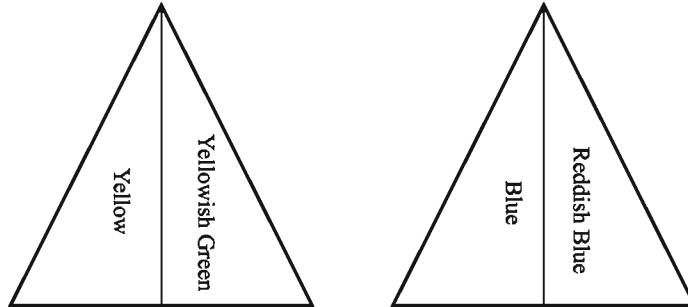

**Fig. 5.12 ANALOGOUS COLOUR HARMONY**

**2. CONTRASTING COLOUR HARMONY**

**a. COMPLEMENTARY COLOUR HARMONY**

When two colours which are straight opposite to each other in the colour wheel are combined then complementary colour harmony is obtained. (Fig 5.13)

- For eg: Yellow and Violet
- Blue and Orange
- Red and Green

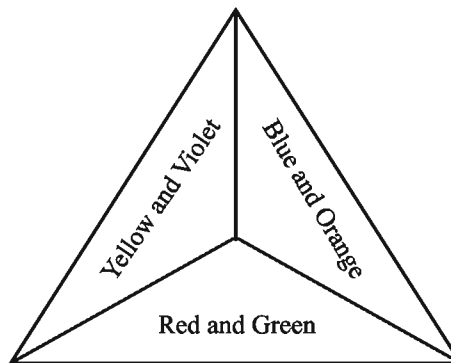
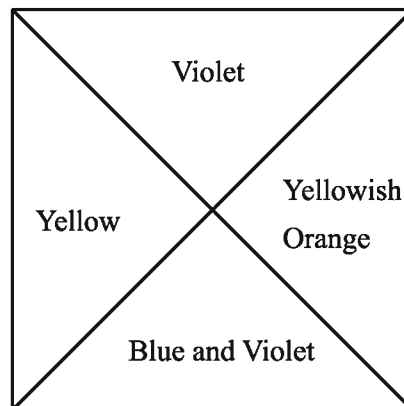

**Fig. 5.13 COMPLEMENTARY COLOUR HARMONY**

**b. DOUBLE COMPLEMENTARY COLOUR HARMONY**

When two adjacent colours in the colour wheel are combined with the corresponding two opposite colours of the wheel, this harmony is obtained. (Fig 5.14)

For eg: - Yellow and yellowish orange are combined with blue and violet colour which are straight opposite to them.

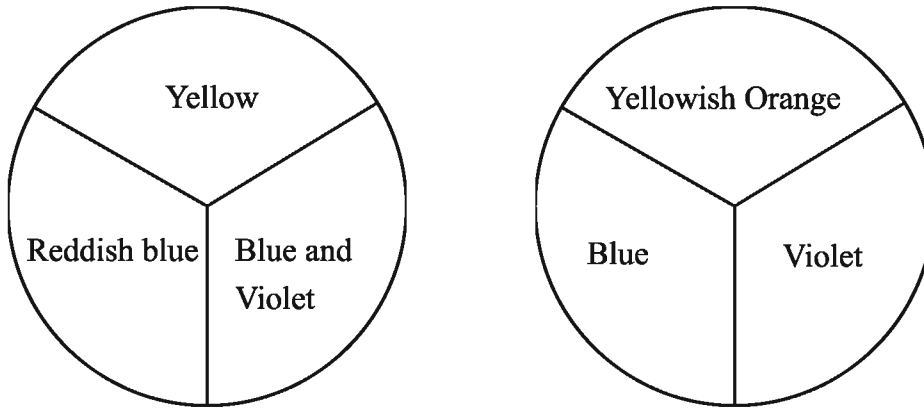

**Fig. 5.14 DOUBLE COMPLEMENTARY COLOUR HARMONY**

**c. SPLIT COMPLEMENTARY COLOUR HARMONY**

When a primary or intermediate colour in the colour wheel is combined with colours which are on either side of the colour straight opposite to it, split complementary colour harmony is obtained. (Fig 5.15)

For example when (i) Yellow is combined with reddish blue and blue violet (ii) Yellowish orange is combined with blue and violet .



**Fig. 5.15 SPLIT COMPLEMENTARY COLOUR HARMONY**

**d. TRIAD**

When colours that coincide with the three vertices of a triangle in the colour wheel are combined then such a triad harmony is obtained. If a triangle made of a piece of paper is placed on the colour wheel, we could obtain a number of possible triad combinations. (Fig 5.16)

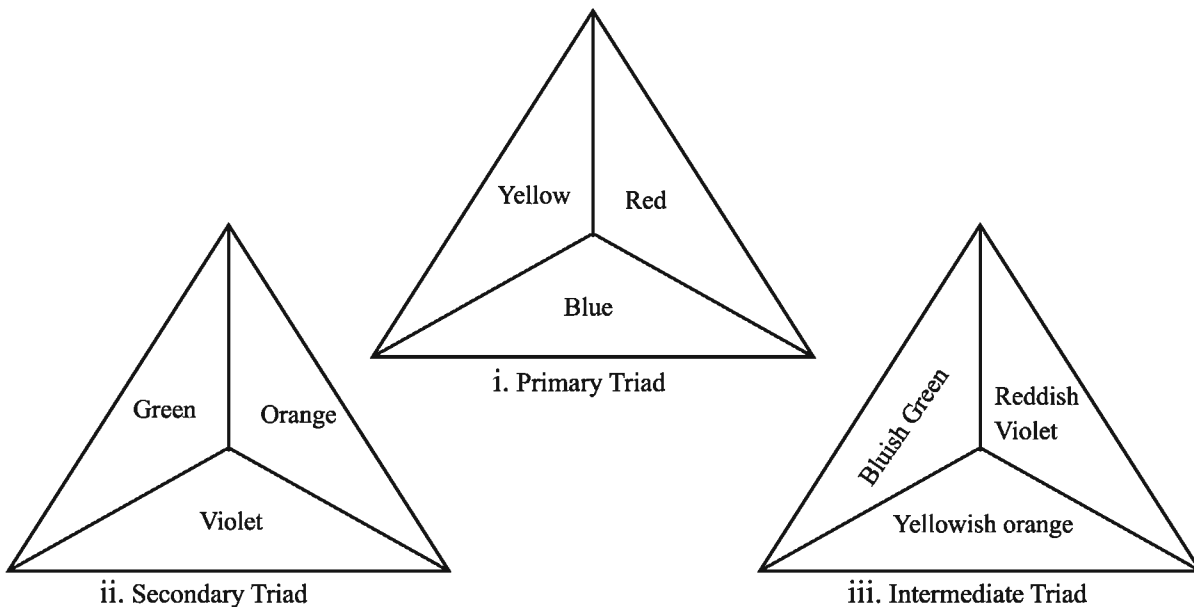

**Fig. 5.16 TRIAD**

i. PRIMARY TRIAD : eg:- Yellow, Red & Blue

ii. SECONDARY TRIAD : eg:- Green & Orangish violet.

iii. INTERMEDIATE TRIAD: eg:- Bluish green, Reddish blue, Yellowish orange

**e. TETRAD:**

When colours which are at equal distances and coinciding with the four corners of a square in the colour wheel are combined a tetrad is obtained.

eg:- Yellowish green, Yellowish orange, Reddish orange and Reddish blue.

Following points must be kept in mind while considering colour combinations.

- i) One colour should be dominating.
- ii) The main colour should be almost 60-70 percent, the second colour should be lesser than this and the third colour should still be much lesser.
- iii) The warmth and coolness of the colour should be kept in mind.
- iv) For emphasizing, a contrast colour should be used.
- v) The lightest tint of a particular colour and its darkest shade must be handled and utilized appropriately.
- vi) Specified combinations or harmony like complementary harmony, analogous harmony or triad can be adopted based on the need or requirement.

**5.11 SELECTION OF COLOURS FOR HOME**

As far as matching of colours for specific rooms in a house is concerned, certain colours will be more appropriate than other colours. For example a bedroom is a resting place which should be cool and calm. Therefore colours which exhibit coolness and calmness like blue, bluishgreen etc. must be chosen for walls of bedrooms.

- i. DRAWING ROOM: This room is widely used by all the members of the family for most of the time in a day. Hence the colour of this room should impart peace, calmness and at the same time should create an active atmosphere for the minds of the people so that their works could be carried out effectively. Therefore the lighter shades of blue, green, red, yellow etc. can be used. To avoid bright sunlight in the room, even deeper shades and colours that induce warmth can be applied.
- ii. DINING HALL: A dining hall is a room which should induce happiness and satisfaction for the members of the family. Hence colours which induce coolness and calmness should be used.
- iii. KITCHEN: Since it's a cooking place, the walls of the kitchen will get affected by smoke and oil. Therefore darker colours like blue, ash, smoky green could be used. Sometimes to create a sort of refreshnes, light colours could be used.

iv) BATHROOM: Colours like white, orange, light blue or light green used for bathrooms induces a sense of refreshing feel and purity for the persons utilizing it.

## **5.12 GENERAL**

Colours may change the appearance of a room by the way it is utilized. The colour matching of a room should coincide with the colour matching of other rooms in a house. There should be compatibility between colours from one room to another. Lighter shades of colours which induce coolness when used will make a small room look bigger and similarly when darker shades of colours and bright colours are used they make a bigger room appear smaller. Even if different colours are used for painting the walls of a room, they make the room look smaller in size. If colours that induce warmth and darker shades of colours are used for ceiling of a room, they make the ceiling appear low. The colour of the ceiling should be brighter than the colour of the walls and the colour of the walls must be brighter when compared to the colour of the flooring. A square room may be made to appear different by choosing contrasting colours for the walls.

## **5.13 HOME FURNISHING AND DECORATION**

Furnitures are those that provide us comfort, help us to ease and relax and at the same time add beauty to home. They are so essential now-a-days that it is impossible to be without them. They are unavoidable.

## **5.14 POINTS TO BE CONSIDERED WHILE SELECTING FURNITURES**

- 1) Furnitures should be chosen depending on the size of the room.
- 2) The shape of a furniture should be simple, hard and at the same time should offer maximum comfort to the person utilizing it.
- 3) Its maintenance should be easy.
- 4) Should not occupy large space.
- 5) Should be light in weight.
- 6) Furnitures utilized by the children should have the provisions for modifying their height according to the convenience of the children using them.
- 7) The furnitures should be easily shiftable from one place to another.
- 8) It should be useful and utilized effectively without much unnecessary decorative designs.
- 9) It should stand firm on the floor without shaking.

## **5.15 ARRANGEMENT OF FURNITURES**

### **GENERAL RULE**

- 1) A particular portion of the arrangement of furnitures should induce interest and the remaining portions of arrangement must obey and follow it.
- 2) The arrangement should be balanced. Peace and harmony could be achieved by a balanced arrangement of furnitures. But too much of balance may sometimes appear boring.



- 3) Care should be taken towards proper arrangement of furnitures. A proper arrangement could be achieved by initially arranging huge furnitures and then based on the availability of remaining space, small furnitures could be arranged.
- 4) Dumping of too much of furnitures in a room need to be avoided.
- 5) Covers and spreads for wooden furnitures must be utilized then and there.
- 6) Huge furnitures covering the walls need to be avoided. Similarly avoiding the centre of the floor space, furnitures can be arranged towards the corners and sides leaving sufficient space to walk through the room without difficulties or obstruction.
- 7) Furnitures should be purchased and arranged based on its need and requirements at appropriate places in the house.

Apart from the above, a housewife should have the following principles in her mind. They are.

- i) Elimination
- ii) Rearrangement
- iii) Concealing

If sufficient funds are available, then old, broken, unused furnitures can be eliminated with new useful ones.

Furnitures available can also be rearranged based on our requirements and to our satisfaction.

Furnitures which are not attractive and which are incompatible can be covered and defective and unattractive furnitures may be covered with suitable decorative covers and can be made to appear attractive.

#### **5.16 FURNITURES IN VARIOUS ROOMS (FIG 5.17)**

1. **LIVING ROOM:** Living room should consist of a comfortable sofa set and few chairs, a teapoy whose height is lesser than that of the sofa set, a television set, radio, musicplayer, albums and a shelf or showcase to place them.
2. **DINING ROOMS:** Dining table and chairs (Foldable)
3. **BED ROOM:** Cot, side table, table lamp, vertical mirror, almirahs
4. **CHILDREN ROOM:** Study table, cot, side table, book shelf
5. **GUEST ROOM:** Sofa cum bed, mirror, side table, table lamp, almirah or shelf to keep baggages.
6. **KITCHEN:** Stool, chair, netted cupboard, kitchen hold articles like gas stove, mixie, grinder, fridge, oven etc.

**FIG. 5.17. FURNITURES IN VARIOUS ROOMS**

# QUESTIONS

## Part A

Choose the correct Answer

(1 mark each)

- 1) Imagination capacity, beautiful taste, and architectural feelings are required for \_\_\_\_  
a) Culture                      b) Good aesthetics  
c) Happiness                  d) Artistic element
- 2) \_\_\_\_ depicts capacity, governance, integrity  
a) vertical line                  b) Curved line                  c) Horizontal Line              d) Inclined line
- 3) \_\_\_\_ denotes the relative position of the lines  
a) Direction                      b) Light                          c) Space                          d) Size
- 4) \_\_\_\_ enhances the beauty of any artistic article  
a) Light                              b) Colour                          c) Size                              d) Texture
- 5) \_\_\_\_ denotes the shape, dimension, character, colour and form of the building  
a) Decorative design          b) Harmony                      c) Structural design              d) Texture
- 6) The plan of \_\_\_\_ could be well expressed by characterization  
a) harmony                          b) balance                          c) proportion                      d) rhythm
- 7) \_\_\_\_ is a smooth path that allows the penetration of our vision from one form or shape to another without much difficulty  
a) Harmony                          b) Rhythm                          c) Proportion                      d) Balance
- 8) Method of obtaining an attraction and impression of our eyes on an article or place is called \_\_\_\_  
a) Radiation                          b) Repetition                      c) Emphasis                      d) Progression of sizes
- 9) \_\_\_\_ are primary triad  
a) Yellow red blue                  b) green orange violet  
c) Yellow, green, bluish green      d) Red orange violet
- 10) \_\_\_\_ may change the appearance of a room by the way it is utilized  
a) Colours                          b) light                              c) Design                          d) Emphasis

**Answer in one or two words**

**(1 mark each)**

- 1) What are the two classification of design?
- 2) What do you mean by 'Harmony of ideas'?
- 3) Write the two types of balances?
- 4) What is meant by proportion of an object ?
- 5) What is colour intensity?
- 6) Define size of an article.

**Part B**

**Answer in one or two sentences**

**(4 marks each)**

- 1) What are the principles of design?
- 2) How is rythm obtained ? Explain.
- 3) How complementary colour harmony is obtained ? Explain.
- 4) How double complementary colour harmony is obtained ? Explain.
- 5) What colours can be given for kitchen ? Explain.
- 6) How split complimentary colour harmony is obtained ? Explain.

**Part-C**

**Answer shortly**

**(10 marks each)**

- 1) Write the requirements of a good structural design and good decorative design .
- 2) What are the points to be considered while selecting furnitures?
- 3) What are the characters of colour? Explain with sketch.
- 4) Write about selection of colours the home? Explain.
- 5) What are the points to be kept in mind while considering colour harmonies?

**Part-D**

**Answer in Detail**

**(20 marks each)**

- 1) Write the elements of art in aesthetics of a house and explain.
- 2) What are the principles of design? Explain.
- 3) Explain the general rules for the arrangement of furniture.
- 4) List the various colour harmonies. Explain them in detail.

**Answer**

- 1) b   2) a   3) a   4) b   5) c   6) a   7) b   8) c   9) a   10) a

# UNIT - VI

## SURVEYING

### 6.1 INTRODUCTION

#### 6.1.1 DEFINITION

Surveying is defined as an art of determining the relative positions of points on, above or beneath the surface of the earth by the measurements of horizontal and vertical distances, angles and directions.

#### 6.1.2 OBJECTIVE

The primary object of a survey is to prepare a plan or map.

#### 6.1.3 USES OF SURVEYING

Surveying may be regarded as an art and science of map making. All engineering and construction projects extending over large areas such as highways, railways, irrigation, water supply etc, are based upon elaborate and complete surveys. In all engineering projects the preparation of accurate plans and sections is the first necessity, for which surveying is essential.

#### 6.1.4 PRIMARY DIVISIONS OF SURVEYING

Surveying may be divided into two classes

- 1) Plane surveying
  - 2) Geodetic surveying
1. **PLANE SURVEYING:** In plane surveying the curvature of the earth is not taken into account, as the surveys extend only over small areas. The degree of accuracy required in this type of surveying is comparatively low. If the area of survey is less than 150 sq.km it is considered as plane. Plane surveys are done for engineering projects on large scale such as factories, bridges, dams, highways, railways, etc., and also for establishing boundaries.
  2. **GEODETIC SURVEYING:** In geodetic surveying, also called trigonometrical surveying, it is necessary to take into account the curvature of the earth, since large distances and areas are covered. The geodetic surveying deals with fixing widely spaced control points and it is carried out in our country by the great trigonometrical survey department of India.

#### 6.1.5 CLASSIFICATION OF SURVEYING

Surveying is classified on the basis of their usage as follows

##### **I. Based on the nature of the field survey**

- 1) Land surveying
  - i) Topographical surveys
  - ii) Cadastral surveys
  - iii) City surveying
- 2) Marine (or) Navigation surveying
- 3) Astronomical surveying

## **II) Based on the object of survey**

- |                       |                      |                         |
|-----------------------|----------------------|-------------------------|
| 1) Engineering survey | 2) Military survey   |                         |
| 3) Mine survey        | 4) Geological survey | 5) Archeological survey |

## **III) Based on the instruments used**

- |                               |                            |
|-------------------------------|----------------------------|
| 1. Chain surveying            | 2. Compass surveying       |
| 3. Levelling                  | 4. Theodolite surveying    |
| 5. Traverse surveying         | 6. Triangulation surveying |
| 7. Tacheometric surveying     | 8. Plane table surveying   |
| 9. Photo grammetric surveying |                            |

## **6.2 CHAIN SURVEYING**

### **6.2.1 DEFINITION**

It is the system of surveying in which the area to be surveyed are measured directly in the field and no angular measurements are taken. There are two main methods of determining distances.

- i) Direct method.
- ii) Computative method.

In the direct method, the distances are actually measured on the ground by means of a chain, tape or other instrument.

In the computative method, the distances are obtained by calculation after the measurement of angles and base distances / staff intercepts.

### **6.2.2 OBJECTIVES OF CHAIN SURVEYING**

The chain surveying is done for the following purposes:

- 1) To secure the data necessary for making a plan
- 2) To secure data for exact description of the boundaries of a piece of land
- 3) To determine its area.
- 4) To divide a piece of land into a number of units.

### **6.2.3 INSTRUMENTS FOR CHAIN SURVEYING**

- |                              |                    |
|------------------------------|--------------------|
| 1) Chain                     | 2) Tape            |
| 3) Arrows                    | 4) Ranging rods    |
| 5) Cross staff               | 6) Plumb bob       |
| 7) Hammer (or) Wooden mallet | 8) Offset rods     |
| 9) Pegs                      | 10) Optical square |

1. **CHAIN:** It is used to measure the distance between two points on the ground. The chain is composed of 100 (or) 150 pieces of galvanized mild steel wire 4mm in diameter, called links. The ends of each link are bent into a loop and connected together by means of three rings. The ends of the chain are provided with brass handles for dragging the chain on the ground, each with a swivel joint so that the chain can be turned round without twisting. The length of the chain is measured from the outside of one handle to the outside of the other. Metallic tags are fixed at various distinctive points of the chain to facilitate quick reading of a chain in surveying measurements.

**TYPES OF CHAINS**

Generally chains are of two types :

- i) Metric chains
  - ii) Non-metric chains
- i. **METRIC CHAINS:** Metric chains are either 20m (or) 30m in length. Every one metre length of chain is divided into 5 links each of length 0.2m. The least count of metric chain is 0.2m. The length of the link is the distance between the centres of the two consecutive middle rings. To enable the reading of fractions of a chain without much difficulty, tallies are fixed at every five metre length for chains of 20m and 30m lengths (fig.6.1 (a)). Small brass rings are provided at every metre length, except where tallies are attached. In metric chains, readings start from ends of handles, increasing towards the centre. The tallies in the chain are as shown in fig 6.1(b).

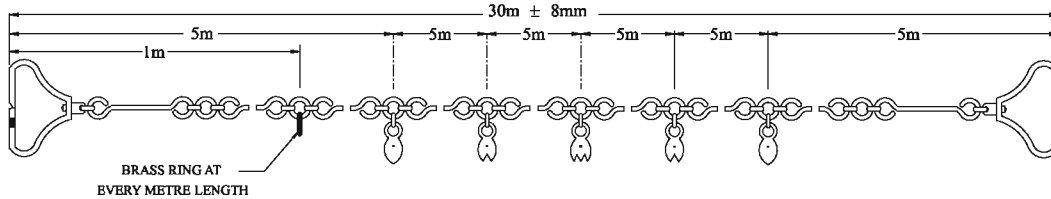

**Fig. 6.1(a) METRIC CHAIN**

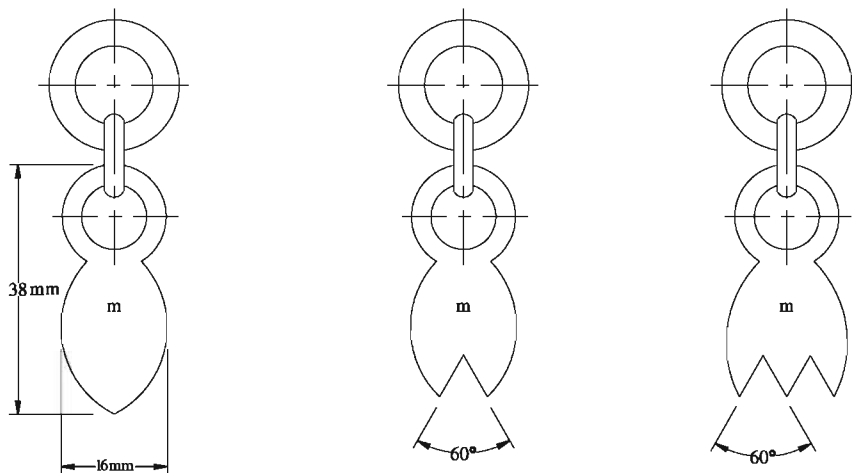

**Fig. 6.1(b) SHAPES OF TALLIES**

ii. **NON METRIC CHAINS:** In this type of chains units other than metric unit are used. Nowadays since metric chains are used everywhere, non metric type of chains became obsolete. Generally these chains are of 2 types.

➤ Engineer's chain

➤ Gunter's chain

➤ **ENGINEER'S CHAIN:** The Engineer's chain is 100 ft. long and consists of 100 links, each link being 1ft long. It is used in all engineering surveys such as roads, rail route & moderately plain areas.

➤ **GUNTER'S CHAIN:** The Gunter's chain is 66 ft. long and is divided into 100 links each 0.66 ft long. It is very convenient for measuring distances in miles and furlongs and to know the area in acre.

10 Gunter's chain = 1 furlong

50 Gunter's chain = 1 mile

10 square Gunter's chain = 1 acre

2. **TAPE:** Tapes are used to measure the lengths to decimal places accuracy. It is also used to measure the offset distance from main survey line. Tapes are made of various materials and are therefore divided into 4 classes

a) Cloth (or) Linen tape

b) Metallic tape

c) Steel tape

d) Invar tape

a. **CLOTH (OR) LINEN TAPE:** These are of closely woven linen or synthetic material and are varnished to resist the moisture to a certain extent. A metal ring is attached to the outer end of the tape. It is included in the length of the tape. These are available in lengths of 10 m, 20 m and 30 m. Each metre length is divided into 10 equal parts and each part is further divided into 10 sub divisions. Each division has a length of 1cm or 0.01m, therefore least count of the tape is 0.01m. It gets affected by dampness quickly. It's length gets altered by stretching and is likely to twist and tangle during measurement due to use and therefore not suitable for precise measurements.

b. **METALLIC TAPE:** It is a linen tape with brass or copper wires woven into it longitudinally to reduce stretching. As it is varnished, the wires are not visible. These are available in 2 m, 5 m, 10 m, 15 m, 20 m and 30 m lengths. The measurements are marked as like in linen tape. It is commonly used for measuring offsets.



- c. **STEEL TAPE:** These are available in lengths as that of metallic tapes and are 6 to 16 mm wide. The markings in this tape are little different from metallic tape. Every metre is divided into 10 parts, each part is called 1 decimeter. The first 10 cm measurement is further divided into 10 parts. Steel tape cannot be used in ground with vegetation and weeds.
  - d. **INVAR TAPE:** This is made up of an alloy of 36% nickel and 64% steel, having very low coefficient of thermal expansion. It is 6 mm wide and available in lengths of 30 m, 50 m and 100 m. It is soft and hence so it has to be handled carefully. It cannot be used for ordinary works.
3. **ARROWS:** It is used to mark the points on the ground or to mark the end of each chain during the chaining process. It is made up of hardened and tempered, steel wire 4 mm in diameter and length of 400 mm. These are pointed at one end whereas a circular ring is formed at its other end as shown in Fig 6.2. It is important to mark the chain lengths in chaining operation. In general, ten arrows are used for one chain.

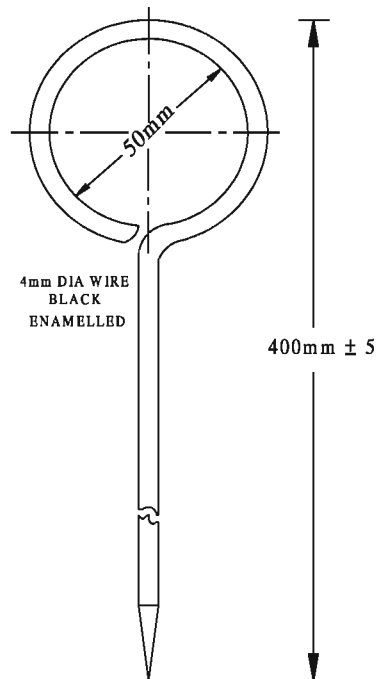

**Fig. 6.2 ARROW**

4. **RANGING ROD:** These are made up of well seasoned straight grain timber (or) steel tubular rods. These are used for marking a point of survey station in such a way that the position of point can be clearly and exactly seen from some distance away. These are 30 mm to 50 mm in diameter and 2 to 3 m long. To fix the ranging rod on ground its bottom end is pointed by providing cross-shoe. These are painted with alternate bands of red and white of 200 mm length in order to make them visible at a distance. Sometimes these are used to mark

the permanent points. To identify these rods conveniently from far off distances, red and white or white and yellow flags of  $25 \text{ cm}^2$  is tied at its top. Fig 6.3

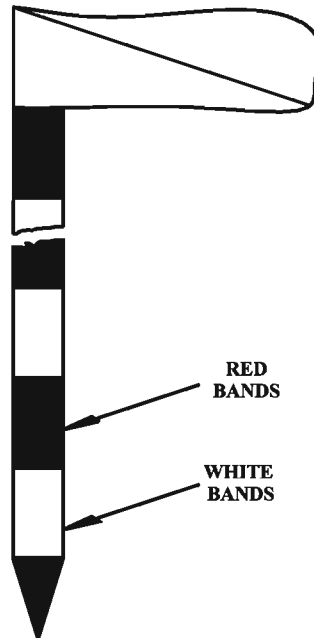

**Fig. 6.3 RANGING ROD**

## **5. CROSS STAFF:**

Cross staff is used for

- i) Establishing perpendicular offset from a given point to a line and
- ii) Setting out a right angle at a given point on a line

There are two forms of cross staff commonly used namely

- a) Open cross staff
  - b) French cross staff
- a. **OPEN CROSS STAFF:** The simplest form of cross staff is the open cross staff shown in fig 6.4(a). It consists of two pairs of vertical slits providing two lines of sight mutually at right angles. Each pair consists of 2 vanes, one is eye vane and other is objective vane.
  - b. **FRENCH CROSS STAFF:** It consists of an octagonal brass tube with slits on all eight sides. It has an alternate vertical slit and an opposite vertical window with a vertical cross hair or a fine wire on each of the four sides. These are used for setting out right angles. On the other sides there are vertical slits, which are at  $45^\circ$  to those previously mentioned, for setting out angles of  $45^\circ$ .

The base carries a brass socket so that it may be fitted on the pointed staff when the instrument is to be used. Fig 6.4(b).

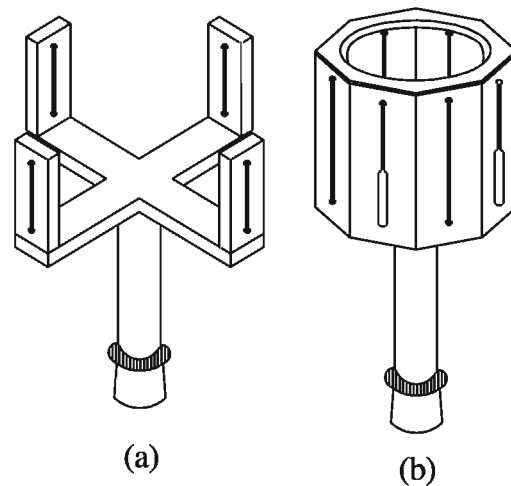

Fig. 6.4 VARIOUS FORMS OF CROSS STAFF

6. **PLUMB BOB:** It is used while measuring distances on sloping ground and transfers the point to the ground by suspending the plumb bob. It is made of steel in a conical shape with a thread connected at the centre. It is generally used for centering. Fig 6.5.

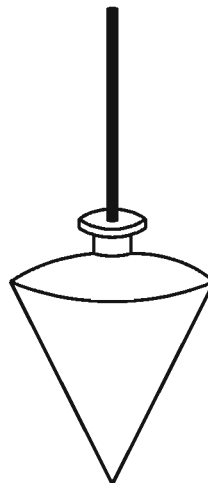

Fig. 6.5 PLUMB BOB

7. **HAMMER:** It is used to give blows to fix the peg on the ground. It is made up of hard wood.
8. **OFFSET ROD:** It is similar to the ranging rod but is usually 3 m long. It is made up of seasoned timber. The top is provided with a stout open hook for pushing or pulling the chain through a hedge or other obstruction. Fig (6.6)
9. **PEG:** There are used to mark definite points on the ground. These are made of hard timber and are tapered at one end. These are usually, 15 cm length with 3 to 5 cm diameter circular in

shape (or) 3 to 5 cm square in shape. The pointed end of peg is covered by iron shoe for easy driving into the ground. Fig (6.7)

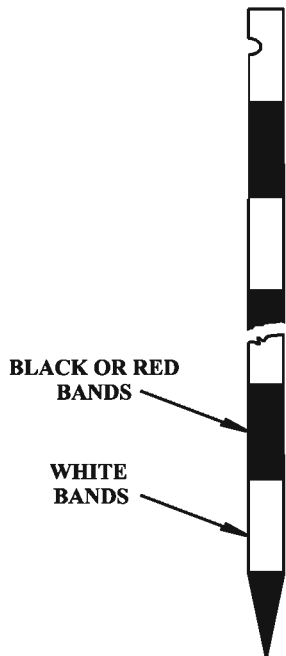

Fig. 6.6 OFFSET ROD

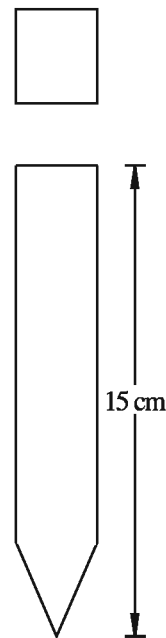

Fig. 6.7 WOODEN PEG

10. OPTICAL SQUARE: Optical square is an instrument used to construct perpendiculars to a chain line. It is circular in shape of 5 cm radius and 1.25 cm height. It has a sliding lid which covers the instrument when not in use thus preventing dust particles from getting inside.

As shown in (fig 6.8) there are two reflecting mirrors H and I fixed at an angle of  $45^\circ$  to each other. The mirror H is half silvered whereas the mirror I is completely silvered. The three openings in the instrument are,

- \* A pinhole or sight hole
- \* A small rectangular slit placed diametrically opposite to the pin hole
- \* A rectangular slot to sight the objects perpendicular to the line "ab".

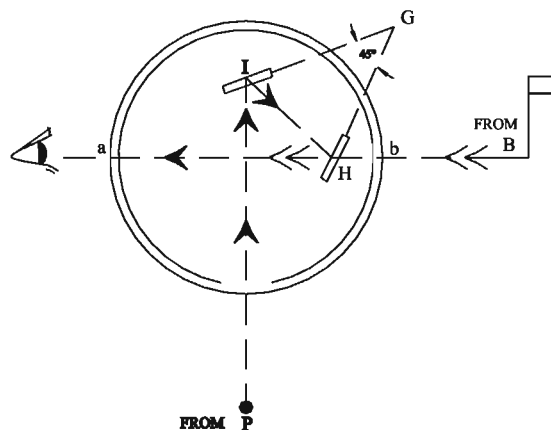

Fig. 6.8 OPTICAL SQUARE

The image of the ranging rod fixed at P falls in the mirror I and gets reflected to mirror H and reaches the eye of the observer. The ranging rod at B can be viewed by the observer directly through the unsilvered portion of the mirror H. The optical square is adjusted until the images of these two ranging rods coincide. Now the perpendicular is set for the chain line.

#### **6.2.4 RANGING:**

The operation of establishing intermediate points on a straight line between the terminal points is known as ranging. If the line is short or the end station is clearly visible, it is easy to put the chain in true alignment. But if it is long or the end station is not clearly visible, it is necessary to place intermediate ranging rods to maintain the direction. It may be done by eye (or) instrumentally by using a line ranger.

#### **TYPES OF RANGING**

Ranging is of two types

- i) Direct ranging
- ii) Indirect ranging

- i. **DIRECT RANGING** : It is called direct when intermediate ranging rods are placed in line by direct observation. Direct ranging is possible only when the end stations are intervisible.
- ii. **INDIRECT RANGING** : It is called indirect when they are interpolated by reciprocal ranging or running an auxiliary line.

#### **6.2.5 OBSTACLES IN CHAINING**

Obstacles to chaining prevent chainman from measuring the distance directly between two points and give rise to a set of problems in which distances are found by indirect measurements.

#### **Obstacles to chaining are of three types:**

- 1) Obstacles to ranging / Obstacle to vision
  - 2) Obstacles to chaining
  - 3) Obstacles to both ranging and chaining
1. **OBSTACLES TO RANGING**: This type of obstacle, in which the ends are not intervisible, is quite common except in flat country. But the distance between the points can be measured.

#### **Example:**

- i) Rising ground
- ii) Hill
- iii) Wooden field forest

Indirect (or) reciprocal ranging is resorted to when both the ends of the survey line are not intervisible either due to high intervening ground or due to long distance between them.

**RECIPROCAL RANGING:** The end points are not intervisible due to

- 1) Rising ground between the ends
- 2) Hill between the ends
- 3) Long distance between the ends

Let A and B be the two end stations of a line with rising ground between them and C and D are the two intermediate points to be established on the chain line. Fig 6.9

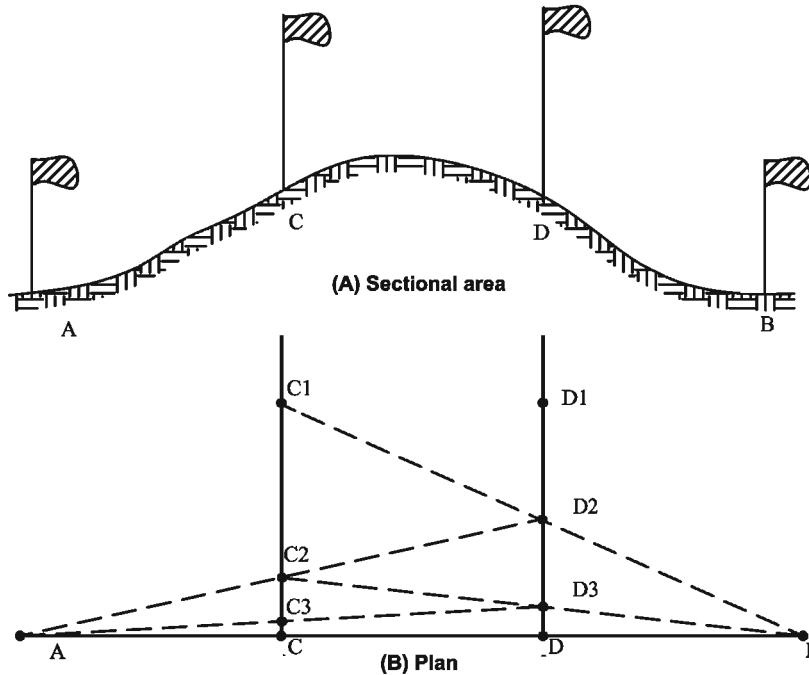

Fig. 6.9 RECIPROCAL RANGING

**PROCEDURE:**

The two chainmen stand at  $C_1$  and  $D_1$  such that the chainman of  $C_1$  can see both the ranging rods at  $D_1$  and B, and the chainman of  $D_1$  can see both the ranging rods at  $C_1$  and A. Now the chainman at  $D_1$  directs the chainman at  $C_1$  to move to  $C_2$  so as to be in line with A. Then the chainman at  $C_2$  directs the chainman at  $D_1$  to move to  $D_2$  so as to be in line with B.

By successively directing each other, the two chainmen proceed to the line AB and finally come at C and D exactly in the line AB. C and D are the required intermediate points between A and B. In this method, the ranging is done reciprocally from points C and D to bring the points in line AB, therefore it is also called reciprocal ranging.

**2. OBSTACLES TO CHAINING:**

In this method the chaining is obstructed, but the two end points are intervisible. The examples for this type of obstacles is a pond, river, lake and plantations (or) hedge. There may be two cases of this obstacle.

- i) When it is possible to chain round the obstacle, i.e. a pond, hedge etc.
- ii) When it is not possible to chain round the obstacle, e.g a river.

**CASE (i). Possible to chain round the obstacle:**

For obstacle to chaining like lake, pond, hedge etc., select two points A and B on either side of the obstacle. Erect two perpendiculars AC and BD from stations A and B. i.e  $AC=BD$ . Join C and D and measure the distance between them. The distance CD is equal to AB. Fig 6.10

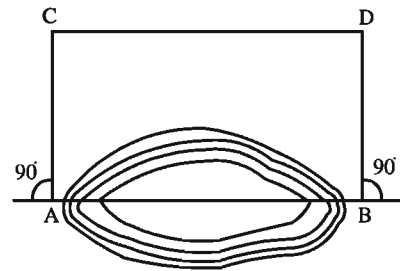

Fig. 6.10 OBSTACLES TO CHAINING

**Case (ii): Impossible to chain round the obstacle**

For obstacle to chaining like river stream etc., select two points A & B on either side of the obstacle. Erect perpendicular AC and bisect it at D. Erect perpendicular CE at C and range E in line with BD. Measure CE. Then  $AB=CE$ . Fig 6.11

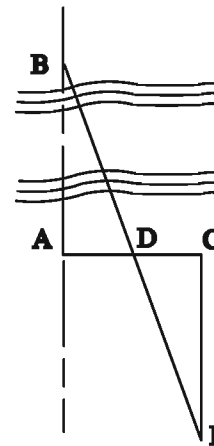

Fig. 6.11 OBSTACLES TO CHAINING

**3. OBSTACLES TO BOTH CHAINING AND RANGING:**

In this case the problem consists of prolonging the line beyond the obstacle and determining the distance across it. A building is a typical example of this class of obstacle. The obstacle can be crossed by the following method.

Choose two points A and B on one side and erect perpendiculars AC and BD of equal length. Join CD and prolong it past the obstacle. Choose two points E and F on CD and erect perpendiculars EG and FH equal to that of AC (or BD). Join GH and prolong it. Measure DE. Evidently  $BG=DE$ . (Fig 6.12)

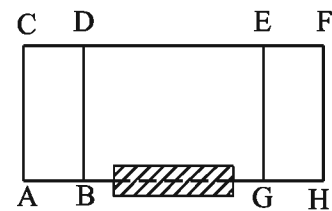

Fig. 6.12 OBSTACLES TO CHAINING

**6.2.6 ERRORS IN CHAINING:**

The errors that occur in chaining are classified into two types

- 1) Compensating errors
- 2) Cumulative errors

## 1. COMPENSATING ERRORS:

These are the errors which are liable to occur in either direction and hence tend to compensate. They do not affect the results much.

These errors are caused by the following:

- i) Incorrect holding of the chain
- ii) Fractional parts of the chain may not be correct if the total length of the chain is adjusted by insertion or removal of a few connection rings from one portion of the chain
- iii) Tape is not calibrated uniformly throughout its length
- iv) During stepping operation adoption of crude method of plumbing
- v) When chain angles are set out with a chain which is not uniformly adjusted or with a combination of chain and tape.

## 2. CUMULATIVE ERRORS:

These are the errors which are liable to occur in the same direction and tend to accumulate. Due to following reasons the measured lengths become more than actual

- i) Bending of links, knots in links, removal of rings during adjustment of the chain
- ii) The slope correction is not applied to the length measured along the sloping ground
- iii) The sag correction is not applied when the tape or the chain is suspended in the air
- iv) Measurements are made along the incorrectly aligned line

## 6.3 LEVELLING

### 6.3.1 DEFINITION

Levelling is defined as the art of determining the relative heights or elevations of points or objects on the earth's surface.

### 6.3.2 TECHNICAL TERMS (Fig 6.13)

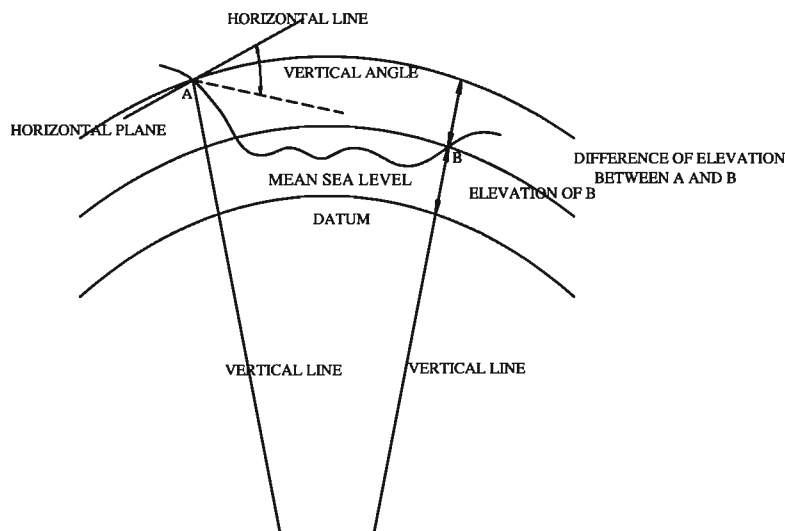

Fig. 6.13 LEVELLING TERMS



1. **LEVEL SURFACE:** A level surface is defined as a curved surface which is parallel to the mean spheroidal surface of the earth. The surface of a still water is truly level surface.
2. **LEVEL LINE:** A level line is a line lying in a level surface.
3. **HORIZONTAL PLANE:** Horizontal plane at a point is a plane tangential to the level surface at that point.
4. **HORIZONTAL LINE:** It is a straight line tangential to the level line at a point. It is perpendicular to the plumb line.
5. **VERTICAL LINE:** It is a line normal to the level line at a point. It is commonly considered to be the line defined by a plumb line.
6. **DATUM:** In order to find out the elevations of points the assumed reference surface of known elevation is called as datum. For important works like dam, canal, mean the level of sea is taken as base line / datum line.
7. **BACK SIGHT:** It is the first staff reading taken, on a point of known elevation or on benchmark or a change point, after the level is set up and leveled. It is also called as plus sight.
8. **FORE SIGHT:** It is the last staff reading taken on a) A point whose elevation is to be determined before closing the work or b) A change point before shifting the instrument. It is also termed as minus sight.
9. **INTERMEDIATE SIGHT:** It is a staff reading taken on a point of unknown elevation / R.L. between back sight and fore sight. It is also called minus sight.
10. **CHANGE POINT:**

It is a point denoting the shifting of the level. It is a point on which the fore and back sights are taken. Fore sight is taken to find the reduced level of the change point and the backsight on the same is taken from the new instrument station to find out the new height of collimation. Any stable and well-defined object is used as a change point. A bench mark may also be taken as a change point.

### **6.3.3 BENCH MARK AND ITS TYPES**

It is a fixed reference point of known elevation. Types of benchmarks are,

- 1) GTS bench mark
- 2) Permanent bench mark
- 3) Temporary bench mark
- 4) Arbitrary bench mark

### **6.3.4 REDUCED LEVEL**

The Vertical distance above or below the datum is known as elevation. Its level is called as reduced level.

### 6.3.5 LEVELLING INSTRUMENTS

The instruments commonly used in direct levelling are

- i) Level
- ii) Levelling staff

### 6.3.6 DIFFERENT TYPES OF LEVELS

Levelling instrument is used to provide a horizontal line of sight and consists of a telescope and level tube. Based on its inner arrangements its types are

- 1) Dumpy level
- 2) Tilting level
- 3) Quick setting level
- 4) Laser level
- 5) Automatic level

### 6.3.7 SETTING UP THE INSTRUMENT

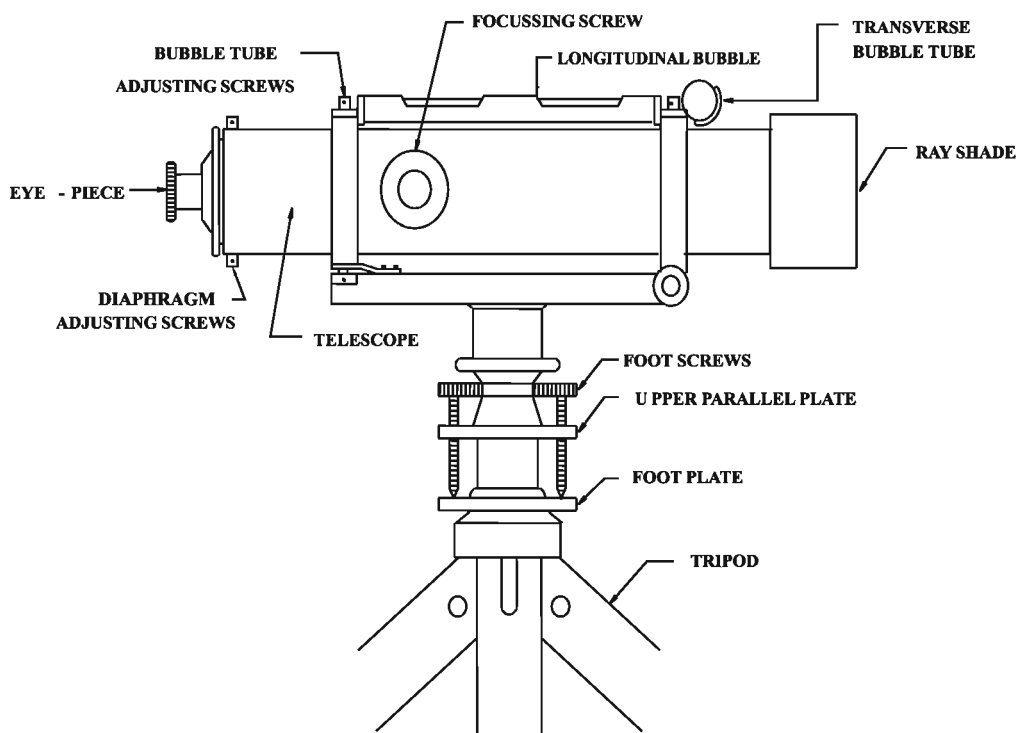

Fig. 6.14 DUMPY LEVEL

**1. TEMPORARY ADJUSTMENTS:** These consist of setting over the station, levelling up & elimination of parallax.

i. **SETTING UP THE INSTRUMENT:** Setting up includes fixing the instrument on the tripod and approximate levelling by adjusting the legs of the tripod.

ii) **FIXING THE INSTRUMENT ON THE TRIPOD:** The clamp screw is released. The level is held in the right hand. It is fixed on the tripod by turning round the lower part with the left hand and is firmly screwed over the tripod.

iii) **LEG ADJUSTMENT:** The instrument is placed at a convenient height with the tripod legs spread well apart and so adjusted that the tripod head is as nearly horizontal as can be, judged by the eye.

## 2. LEVELLING UP

### LEVELLING WITH A THREE SCREW HEAD:

- i) The bubble tube is kept parallel to any two foot screws. The two foot screws are turned both inwards or both outwards until the bubble is central as shown in Fig 6.15(a). The bubble will move in the direction of movement of the left thumb.
- ii) The telescope is rotated through  $90^\circ$  so that it lies over the third foot screw Fig 6.15 (b)

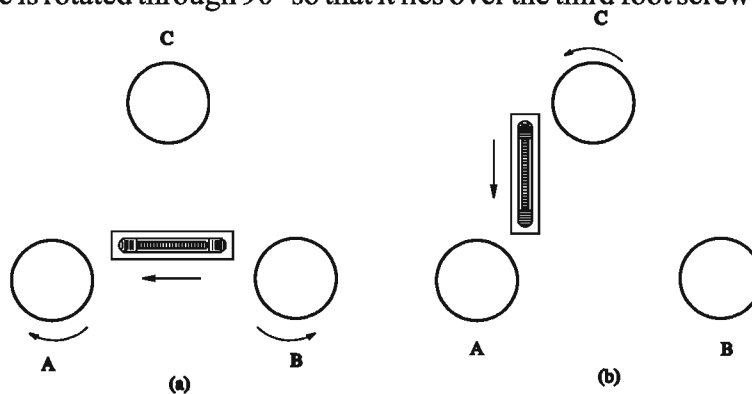

Fig. 6.15 LEVELLING WITH FOOT SCREWS

- iii) The third screw is turned until the bubble is central.
- iv) The telescope is rotated back through  $90^\circ$  to its original position and adjusted as in step 1. The procedure in steps 1 to 3 are repeated till the bubble remains central in both the positions.
- v) The telescope is now rotated through  $180^\circ$ . The bubble should remain central if the instrument is in proper adjustment.

**3. ELIMINATION OF PARALLAX:** It is defined as the process of making the image of an object to exactly fall on the plane of cross-hairs (diaphragm). It consists of focussing the eyepiece and objective of the level.

- i) **FOCUSSING THE EYEPiece:** This operation is done to make the cross-hairs to appear distinct and clearly visible. The following steps are involved
  - a) The telescope is directed towards sky or a sheet of white paper is held in front of the objective.
  - b) The eyepiece is moved in or out till the cross-hairs appear distinct.
- ii) **FOCUSSING THE OBJECTIVE:** This operation is done to bring the image of the object in the plane of the cross-hairs. The following steps are involved
  - a) The telescope is directed towards the staff.
  - b) The focussing screw is turned until the image appears clear and sharp.

### 6.3.8 LEVELLING STAFF

A levelling staff is a straight rectangular, wooden prism. It is painted, graduated into metres and small divisions, the foot of the staff representing zero reading. The purpose of the levelling staff is to determine the amount by which the station is above or below the line of sight. The various types of levelling staff (Fig 6.16) are

- 1) Solid staff
- 2) Folding staff
- 3) Telescopic staff and
- 4) Target staff

In the first 3 types, the reading can be directly taken by the surveyor through the telescope.

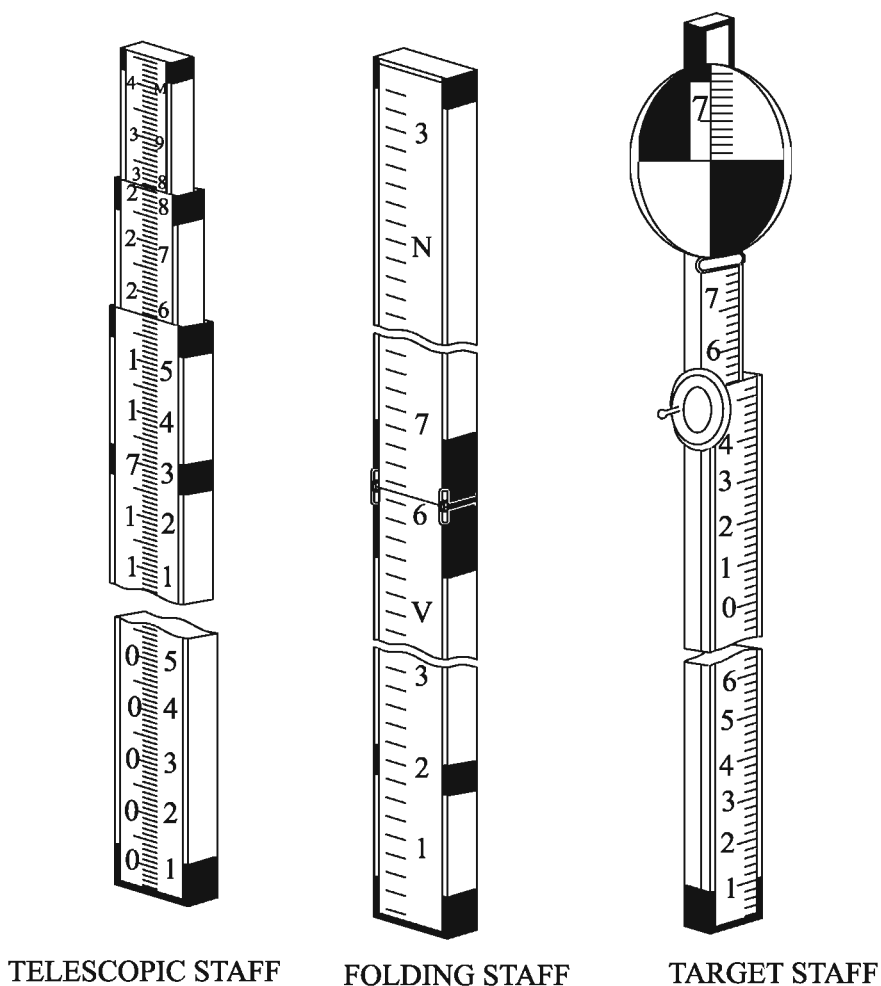
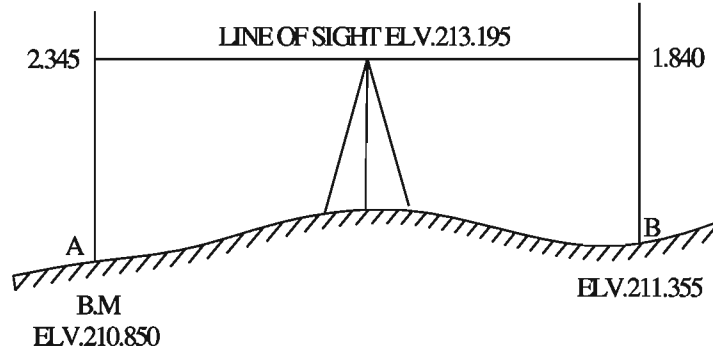

Fig. 6.16 LEVELLING STAFF

### 6.3.9 REDUCTION OF LEVELS

Reduction of levels means reducing the elevation of a point from the observed staff readings. It can be done by two methods.

- 1) Height of collimation method.
- 2) Rise and fall method



**1. HEIGHT OF COLLIMATION METHOD:** In this method, the reduced level of the line of collimation or height of collimation (HCL) is calculated for each setting of the instrument by adding back sight reading (plus sight) to the elevation of the B.M. or previous station. The reduced levels of the intermediate points and the first change point are then obtained by subtracting the staff readings taken on the points (IS&FS) from the plane of collimation (HCL). When the instrument is shifted to the second position, a new plane of collimation is setup. The elevation of the new plane of collimation is obtained by adding the backsight reading taken on the change point from the second position of the level to the reduced level of the first change point.

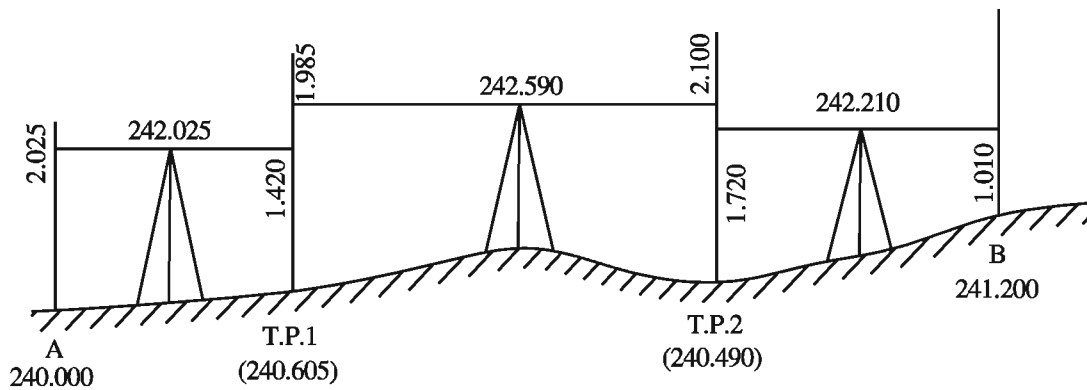

Height of collimation = R.L of Benchmark + Back sight reading

RL of other stations = Height of collimation (HCL) - I.S / FS reading.

**2. RISE AND FALL METHOD:** In this method, the difference of level between consecutive points is found by comparing the staff readings. The difference between their staff readings indicate a rise or fall according as the staff reading at the point is smaller or greater than that at the preceding point.

B.S -I.S (or) I.S -I.S(or)I.S -F.S

(+) ve value indicates rise and (-)ve value indicates fall. Reduced level of each point are found by adding the rise to or subtracting the fall from the reduced level of the preceding point.

In general

First reading - second reading = + rise or - fall

**Note:**

R.L of any point = R.L of preceding point + rise or - fall

**EXAMPLE 1:**

The readings taken on various stations are entered in the level field book as shown below. Reduce the levels by the

- a) Height of collimation method
- b) Rise and fall method

Station	B.S	I.S	F.S	R.L	Remarks
A	0.865			400.000	B.M <sub>1</sub>
B	1.025		2.105		Cp <sub>1</sub>
C		1.580			platform
D	2.230		1.865		Cp <sub>2</sub>
E	2.355		2.835		Cp <sub>3</sub>
F			1.760		BM <sub>2</sub>

**SOLUTION:**

**a) HEIGHT OF COLLIMATION METHOD**

Station	B.S	I.S	F.S	Height of collimation level (HCL)	R.L	Remarks
A	0.865			400.865	400.000	B.M <sub>1</sub> on Gate
B	1.025		2.105	399.785	398.760	CP <sub>1</sub>
C		1.580			398.205	Platform
D	2.230		1.865	400.150	397.920	CP <sub>2</sub>
E	2.355		2.835	399.670	397.315	CP <sub>3</sub>
F			1.760		397.910	BM <sub>2</sub>

Σ BS = 6.475

Σ FS = 8.565

**Note :** Height of collimation (HCL) = RL of BM+B.S reading on the BM.

(HCL - IS) or (HCL-FS) of next station = RL of that station

$$400.000 + 0.865 = 400.865; 400.865 - 2.105 = 398.760$$

$$398.760 + 1.025 = 399.785; 399.785 - 1.580 = 398.205$$

$$399.785 - 1.865 = 397.920$$

$$397.920 + 2.230 = 400.150$$

$$400.150 - 2.835 = 397.315$$

$$397.315 + 2.355 = 399.670$$

$$399.670 - 1.760 = 397.910$$

Arithmetic Check:  $\Sigma B.S - \Sigma F.S = 6.475 - 8.565 = -2.090$  m

R.L. of last point - R.L. of first point =  $397.910 - 400.000 = -2.090$  m

$$\% (\Sigma B.S - \Sigma F.S) = (\text{R.L. of last point} - \text{R.L. of first point})$$

Hence, the calculations are correct.

#### b) RISE AND FALL METHOD

Station	B.S	I.S	F.S	Rise	Fall	R.L	Remarks
A	0.865					400.000	B.M on Gate
B	1.025		2.105		1.240	398.760	CP <sub>1</sub>
C		1.580			0.555	398.205	Platform
D	2.230		1.865		0.285	397.920	CP <sub>2</sub>
E	2.355		2.835		0.605	397.315	CP <sub>3</sub>
F			1.760	0.595		397.910	BM <sub>2</sub>

$$\Sigma B.S = 6.475$$

$$\Sigma F.S = 8.565 \quad \Sigma \text{Rise} = 0.595 \quad \Sigma \text{Fall} = 2.685$$

Difference of level between consecutive readings is obtained by comparing the difference in the readings between them. If (first reading - second reading) is plus, the second station is at a higher level indicating rise. If the difference is minus, it indicates a fall.

Station

$$B = 0.865 - 2.105 = -1.240 \text{ (Fall)}$$

$$C = 1.025 - 1.580 = -0.555 \text{ (Fall)}$$

$$D = 1.580 - 1.865 = -0.285 \text{ (Fall)}$$

$$E = 2.230 - 2.835 = -0.605 \text{ (Fall)}$$

$$F = 2.355 - 1.760 = +0.595 \text{ (Rise)}$$

R.L of station: A = 400.000

$$B = 400.00 - 1.240 = 398.760$$

$$C = 398.760 - 0.555 = 398.205$$

$$D = 398.205 - 0.285 = 397.920$$

$$E = 397.920 - 0.605 = 397.315$$

$$F = 397.315 + 0.595 = 397.910$$

Arithmetic Check :

$$\begin{aligned} \text{Sum of B.S} - \text{sum of F.S} &= \text{Sum of Rise} - \text{Sum of fall} = \text{Last R.L} - \text{First R.L} \\ &= 6.475 - 8.565 = 0.595 - 2.685 = 397.910 - 400.000 \\ &= -2.090 = -2.090 = -2.090 \text{ m} \end{aligned}$$

Hence, the calculations are correct.

### EXAMPLE 2

The following consecutive readings were taken with a dumpy level:

1.420, 1.835, 1.545, 0.450, 1.125, 2.320, 1.980, 1.455, 1.905 and 0.550

The instrument was shifted after the second and the sixth readings. The first reading was taken on the staff held on the bench mark of R.L. +100.000 m. Calculate the reduced levels of the points and show the usual checks by :

- a) Height of collimation method                      b) Rise and fall method

### SOLUTION:

**a) HEIGHT OF COLLIMATION METHOD:** Since the instrument was moved after the second and the sixth readings 1.835 and 2.320 are foresights and 1.545 and 1.980 are the corresponding back sights. The first reading taken on the benchmark is back sight. The last reading is foresight. The other readings are intermediate sights. The reduced levels of points calculated by the height of collimation method are as follows :

Station	B.S	I.S	F.S	Height of collimation level (HCL)	R.L	Remarks
1	1.420			101.420	100.000	BM <sub>1</sub>
2	1.545		1.835	101.130	99.585	C.P <sub>1</sub>
3		0.450			100.680	
4		1.125			100.005	
5	1.980		2.320	100.790	98.810	C.P <sub>2</sub>
6		1.455			99.335	
7		1.905			98.885	
8			0.550		100.240	BM <sub>2</sub>

$$\Sigma \text{BS} = 4.945 \qquad \Sigma \text{FS} = 4.705$$



R.L of B.M+B.S=HCL ; HCL-I.S/FS=RL of next point

$$100 + 1.420 = 101.420; 101.420 - 1.835 = 99.585$$

$$99.585 + 1.545 = 101.130; 101.130 - 0.450 = 100.680$$

$$101.130 - 1.125 = 100.005$$

$$101.130 - 2.320 = 98.810$$

$$98.810 + 1.980 = 100.790$$

$$100.790 - 1.455 = 99.335$$

$$100.790 - 1.905 = 98.885$$

$$100.790 - 0.550 = 100.240$$

Arithmetic Check :

Sum of B.S - sum of FS = Last RL - First RL

$$4.945 - 4.705 = 100.240 - 100.000$$

$$0.240 \text{ m} = 0.240 \text{ m}$$

Hence the calculations are correct.

**b) RISE AND FALL METHOD:** Since the instrument was moved after the second and the sixth readings 1.835 and 2.320 are foresights and 1.545 and 1.980 are the corresponding backsights. The first reading taken on the benchmark is backsight. The last reading is Foresight. The other readings are intermediate sights. The reduced levels calculated by the rise and fall method are as follows :

Station	B.S	I.S	F.S	Rise	Fall	R.L	Remarks
1	1.420					100.000	B.M.1
2	1.545		1.835		0.415	99.585	C.P <sub>1</sub>
3		0.450		1.095		100.680	
4		1.125			0.625	100.005	
5	1.980		2.320		1.195	98.810	C.P <sub>2</sub>
6		1.455		0.525		99.535	
7		1.905			0.450	98.885	
8			0.550	1.355		100.240	BM2

$$\Sigma \text{BS} = 4.945$$

$$\Sigma \text{FS} = 4.705$$

$$\Sigma \text{Rise} = 2.975$$

$$\Sigma \text{Fall} = 2.735$$

Difference of level between consecutive readings is obtained by comparing the difference in the readings between them. If (first reading - second reading) is plus, the second point is at a higher level indicating rise. If the difference is minus, it indicates a fall.

Station

$$2 = 1.420 - 1.835 = -0.415 \text{ (Fall)}$$

$$3 = 1.545 - 0.450 = +1.095 \text{ (Rise)}$$

$$4 = 0.450 - 1.125 = -0.675 \text{ (Fall)}$$

$$5 = 1.125 - 2.320 = -1.195 \text{ (Fall)}$$

$$6 = 1.980 - 1.455 = +0.525 \text{ (Rise)}$$

$$7 = 1.455 - 1.905 = -0.450 \text{ (Fall)}$$

$$8 = 1.905 - 0.550 = +1.355 \text{ (Rise)}$$

R.L of station: 1 = 100.000

$$2 = 100.000 - 0.415 = 99.585$$

$$3 = 99.585 + 1.095 = 100.680$$

$$4 = 100.680 - 0.675 = 100.005$$

$$5 = 100.005 - 1.195 = 98.810$$

$$6 = 98.810 + 0.525 = 99.335$$

$$7 = 99.335 - 0.450 = 98.885$$

$$8 = 98.885 + 1.355 = 100.240$$

Arithmetic Check :

$$\Sigma B.S - \Sigma F.S = \Sigma \text{ Rise} - \Sigma \text{ fall} = \text{Last R.L} - \text{First R.L}$$

$$= 4.945 - 4.705 = 2.975 - 2.735 = 100.240 - 100.000$$

$$= 0.240 \text{ m} = 0.240 \text{ m} = 0.240 \text{ m}$$

Hence, the calculations are correct.

### EXAMPLE 3

The following consecutive readings were taken with a level and a 4 m staff on a continuously sloping ground.

0.650, 1.535, 1.955, 2.530, 2.985, 3.480, 1.250, 1.960, 2.400, 3.640, 0.800, 1.300, 1.630 and 2.755 m

The reduced level of the first point A was 100.000 m. Rule out a page of a level field book and enter the above readings. Calculate the reduced levels of the points by the collimation method and rise and fall method.

**SOLUTION:**The first reading of 0.650 at station A must be a backsight reading. Since the readings were taken on a continuously sloping ground with a 4.0m staff, the largest reading that can be taken is 4m. Therefore the position of the level must have been changed after the largest reading of each series, such as after 3.480 (of the 1<sup>st</sup> series) and 3.460 (of the 2<sup>nd</sup> series). The last observation of 2.755 must be a foresight reading. Hence, the observations 3.480, 3.640 and 2.755 are booked in the foresight column. Each of the foresight readings 3.480 and 3.640, at the change point, are preceded by backsight readings 1.250 and 0.800 respectively. All the remaining readings are intermediate sight readings.

- a) Height of collimation method
- b) Rise and fall method

**a) HEIGHT OF COLLIMATION METHOD**

Station	B.S	I.S	F.S	Height of collimation level (HCL)	R.L	Remarks
A	0.650			100.650	100.000	B.M <sub>1</sub>
		1.535			99.115	
		1.955			98.695	0
		2.530			98.120	
		2.985			97.665	
	1.250		3.480	98.420	97.170	C.P <sub>1</sub>
		1.960			96.460	
		2.400			96.020	
	0.800		3.640	95.580	94.780	C.P <sub>2</sub>
		1.300			94.280	
		1.630			93.950	
B			2.755		92.825	BM <sub>2</sub>

$\Sigma B.S = 2.700$

$\Sigma F.S = 9.875$

Arithmetic Check :

$\Sigma B.S - \Sigma F.S = 2.700 - 9.875 = - 7.175 \text{ m}$

R.L. of last point - R.L. of first point =  $92.825 - 100 = -7.175 \text{ m}$

$\therefore \Sigma B.S - \Sigma F.S = \text{R.L. of last point} - \text{R.L. of first point}$

Hence, the calculations are correct.

## b) RISE AND FALL METHOD

Station	B.S	I.S	F.S	Rise	Fall	R.L	Remarks
A	0.650					100.00	B.M <sub>1</sub>
		1.535			0.885	99.115	
		1.955			0.420	98.695	
		2.530			0.575	98.120	
		2.985			0.455	97.665	
	1.250		3.480		0.495	97.170	C.P <sub>1</sub>
		1.960			0.710	96.460	
		2.400			0.440	96.020	
	0.800		3.640		1.240	94.780	C.P <sub>2</sub>
		1.300			0.500	94.280	
		1.630			0.330	93.950	
B			2.755		1.125	92.825	BM <sub>2</sub>

Arithmetic Check :

$$\begin{aligned} \text{Sum of B.S} - \text{Sum of F.S} &= \text{Sum of Rise} - \text{Sum of fall} = \text{Last R.L} - \text{First R.L} \\ &= 2.700 - 9.875 = 0 - 7.175 = 92.825 - 100.000 \\ &= -7.175 \text{ m} = -7.175 \text{ m} = -7.175 \text{ m} \end{aligned}$$

Hence, the calculations are correct.

## QUESTIONS

### PART-A

Choose the correct Answer

(1 mark each)

- The primary objective of surveying is the preparation of -----.  
 a) boundaries      b) measuring distance      c) plan or map      d) right angles
- Geodetic surveying is carried out by -----.  
 a) Land reforms department      b) Great trigonometrical survey department of India  
 c) Highways department      d) P.W.D department
- does not belong to the classification based on the instrument used.  
 a) Mine surveying      b) Chain surveying  
 c) Plane table surveying      d) Theodolite surveying
- does not belong to the classification based on the object of surveying.  
 a) Engineering survey      b) Traverse survey      c) Military survey      d) Geological survey
- The instrument that is not used in chain surveying is -----.  
 a) Chain      b) Ranging rods      c) Pegs      d) Compass

- 6) In metric chain, length of one link is ----- .  
 a) 0.2 m                      b) 0.2 cm                      c) 200 cm                      d) 20 mm
- 7) Length of an Engineer's chain is -----.  
 a) 150 ft                      b) 100 ft                      c) 66 ft                      d) 125ft
- 8) ----- is not an obstacle in ranging.  
 a) Rising ground                      b) Hill                      c) Forest                      d) Building
- 9) Example for obstacles to both chaining and ranging is-----  
 a) building                      b) river                      c) lake                      d) pond
- 10) The first staff reading taken after any set up of the levelling instrument is called -----.  
 a) change point                      b) bench mark                      c) fore sight                      d) back sight
- 11) Two primary classification of surveying are -----&----- .  
 a) Chain surveying & marine surveying    b) land surveying & astronomical surveying  
 c) plane surveying & geodetic surveying    d) city surveying & archeological surveying\
- 12) Optical square is used to set out----- .  
 a) horizontal plane                      b) vertical plane                      c) datum line                      d) right angles
- 13) The staff reading taken between back sight and foresight is -----.  
 a) bench mark    b) reduced level                      c) intermediate sight                      d) change point
- 14) The last reading taken before shifting the instrument is-----.  
 a) fore sight                      b) back sight                      c) intermediate sight                      d) reduced level

**Answer in one or two words**

**(1 mark each)**

- 1) What are the two types of cross staff?
- 2) What are the two methods of reduction of levels?
- 3) What are the types of errors in chaining?
- 4) Mention any two uses of chain in surveying?
- 5) What do you mean by benchmark?
- 6) What is meant by reduced level and what is its alternative name?

## PART-B

Answer in one or two sentences

(4 marks each)

- 1) Define surveying.
- 2) What are the uses of surveying?
- 3) Classify surveying based on the object of survey?
- 4) What are the objects of chain surveying?
- 5) Write the principle of operation of optical square.
- 6) Define the term levelling.
- 7) What is the need for a change point in levelling?
- 8) Write the types of bench mark?
- 9) What are the different types of levels used in levelling?
- 10) Define levelling staff and mention its various types?

## PART-C

Answer shortly

(10 marks each)

- 1) What is meant by surveying? Classify surveying based on :
  - a) the nature of the field survey
  - b) the object of survey
  - c) the instruments used.
- 2) Explain with neat diagram the construction and working of an optical square.
- 3) Explain cumulative and compensating errors?
- 4) What is meant by levelling? Define the technical terms used in levelling?

## PART-D

Answer in detail

(20 marks each)

- 1) List the instruments used for chain surveying? Explain their functions and uses?
- 2) What are the different types of tapes? Explain each one of them in detail.
- 3) Explain how will you continue chaining past the following obstacles?
  - a) River
  - b) Rising ground
  - c) Building
- 4) Describe the Height of Collimation and Rise and Fall methods of reduction of the levels.
- 5) The following staff readings have been taken during levelling :

0.430	1.110	2.010	1.680
2.110	1.810	0.495	0.680
1.810	1.460	0.485	0.980
0.415			

The instrument has been shifted after second, fifth, seventh and tenth readings. Enter the readings in level book form and reduce the level by any one of the method. The R.L of the point of first reading is +30.000 m. Do the arithmetical check.

- 6) Staff readings taken by a levelling instrument are 1.420, 1.835, 0.450, 1.125, 2.320, 1.905, 1.455, 1.905 and 0.550. Instrument is shifted after 2nd and 6th reading. If the R.L. of first station is +100.000 m, calculate the reduced level of points by any one of the method. Do the arithmetical check.
- 7) The following readings were taken by a levelling instrument. Calculate the R.L. of the stations by the height of collimation method.

Station	B.S	I.S	F.S	R.L	Remarks
A	3.185			+100.000	BM 1
B	2.165		2.845		CP 1
C	2.785		2.645		CP 2
D	2.645		0.985		CP 3
E		0.430			
F	1.570		1.465		CP 4
G	1.945		0.790		CP 5
			0.565		BM 2

- 8) The following readings were taken by a levelling instrument. The instrument was shifted after second, fifth and eighth readings 0.675, 1.230, 0.750, 2.565, 2.225, 1.935, 1.835, 3.220, 3.115 and 2.875 m. R.L. of the point of first reading is +100.000 m. Enter the readings in a tabular column and find the RL of other points by the height of collimation method .

### Answers

- 1)c 2)b 3)a 4)b 5)d 6)a 7)b 8)d 9)a 10)d 11)c  
12)d 13)c 14)a

# UNIT - VII

## HYDRAULICS AND HYDRAULIC MACHINERY

### 7.1 HYDRAULICS

#### 7.1.1 INTRODUCTION

Fluid mechanics or hydraulics is a branch of science that deals with the behaviour of fluids (liquids or gases) at rest as well as in motion.

The study of fluid mechanics deals with statics, kinematics and dynamic aspects of fluids. The study of fluids at rest is called fluid statics. The study of fluids in motion, where pressure forces are considered is called fluid dynamics.

#### 7.1.2 FLUIDS

A fluid is a substance which flows from one place to another and offers no resistance to shear deformation and will continue to deform when subjected to shear stresses. A fluid has no definite shape and it takes the shape of the container in which it is contained. A small force on a fluid will change its shape. It is classified into liquids and gases.

#### 7.1.3 PROPERTIES OF FLUIDS

- 1) Density
- 2) Specific weight / weight density
- 3) Specific gravity / relative density
- 4) Surface tension
- 5) Viscosity
- 6) Capillarity

##### 1. Density:

Density or mass density is defined as the mass of the fluid per unit volume. The unit of density is  $\text{kg/m}^3$ . It is represented by the symbol  $\rho$  (rho).

$$\text{Density, } [\rho] = \frac{\text{Mass of fluid } (M)}{\text{Volume of fluid } (V)}$$

The density of water at  $4^{\circ}\text{C}$  at mean sea level is  $1000 \text{ kg/m}^3$ .

##### 2. Specific Weight / weight density

Specific weight is defined as the ratio of weight (W) to volume (V) of a fluid. It is denoted by the letter "w"

$$w = W/V$$

$$\begin{aligned} \text{But, Weight} &= \text{Mass} \times \text{Acceleration due to gravity} \\ &= M \cdot g \end{aligned}$$

$$\text{Specific weight } (w) = \frac{W}{V}$$

$$w = \frac{M \times g}{V}$$

$$w = \rho \cdot g \quad \text{where} \quad \rho = \frac{M}{V}$$



It helps in the determination of weight of liquids. The specific weight of water is  $9810 \text{ N/m}^3$ .

### 3. Specific gravity / Relative density:

Specific gravity is defined as the ratio of the weight density of a fluid to the weight density of a standard fluid. Standard fluid is taken as water for liquids and air for gases.

It is a dimensionless quantity and is denoted by the symbol 'S'. It helps in determining whether the given liquid is lighter or heavier than the standard liquid. The given liquid is lighter than the standard liquid if its specific gravity value is less than 1 and it is heavier than the standard liquid if its specific gravity value is more than 1. It also helps in knowing the number of times the liquid is heavier than the standard liquid.

$$S \text{ (for liquids)} = \frac{\text{weight density of liquid}}{\text{weight density of water}}$$

$$S \text{ (for gases)} = \frac{\text{weight density of gas}}{\text{weight density of air}}$$

The specific gravity of water and mercury are 1.00 and 13.60 respectively.

### 4. Surface Tension :

The property of a liquid which offers a tensile resistance at its surface in the longitudinal and transverse direction is called 'Surface Tension'. The surface tension of a liquid is measured in terms of the tensile strength of the surface film per unit width. It is represented by  $\sigma$  (sigma). The unit of surface tension is N/mm. i.e. Newton / millimeter

### 5. Viscosity :

Viscosity is defined as the property of a fluid which offers resistance to the movement of one layer of fluid over another adjacent layer of the fluid. It is denoted by the symbol  $\mu$ .

The unit of viscosity is  $\text{N}\cdot\text{s}/\text{m}^2$  or Poise

The viscosity of water at  $20^\circ\text{C}$  is 0.01 Poise

### 6. Capillarity

Capillarity is defined as a phenomenon of rise or fall of a liquid surface in a small tube relative to the adjacent general level of liquid when the tube is held vertically in the liquid. The rise of liquid surface is known as capillary rise (Fig 7.1 (a)) and the fall of liquid surface is known as capillary fall (Fig 7.1 (b)). It depends on the specific weight of the liquid, diameter of the tube and surface tension of the liquid

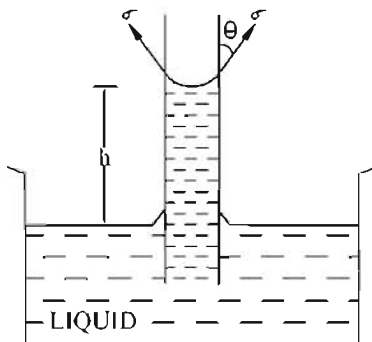

Fig. 7.1 (a) CAPILLARY RISE

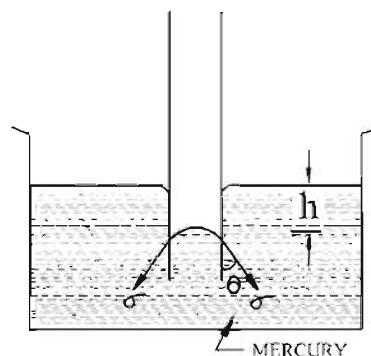

Fig. 7.1 (b) CAPILLARY FALL

### 7.1.4 PRESSURE (p)

The pressure at a point is defined as the ratio of the force or thrust to the area on which the force is distributed. It is also called as "Intensity of pressure" or "Pressure intensity".

$$p = \frac{F}{A} = \frac{\text{Force}}{\text{Area}}$$

The unit of pressure is  $\text{N/mm}^2$ , Pascal (Pa) etc.,

$$(\because 1\text{Pa} = 1\text{N/m}^2)$$

### 7.1.5 PRESSURE HEAD

The intensity of pressure "p" at any point in a fluid mass can be expressed in terms of the height "h" of the fluid column which causes the pressure. If the specific weight of the fluid is w then,

$$p = wh.$$

The height of the fluid 'h' is called the pressure head at the point

$$h = \frac{p}{w} = \frac{p}{\rho g}$$

For example the atmospheric pressure is 760 mm of mercury.

### 7.1.6 HYDROSTATIC PRESSURE ON SURFACE

The intensity of pressure increases when the depth of liquid increases from the surface of the liquid. This can be understood from the expression below.

$$p = w.H$$

$$p = \text{liquid pressure}$$

$$w = \text{specific weight of liquid}$$

$$H = \text{height of the liquid from the point of pressure measurement.}$$

### 7.1.7 TOTAL PRESSURE

Total pressure is defined as the force exerted by a static fluid on a surface either plane or curved, when the fluid comes in contact with the surface. This force always acts normal to the surface. It is represented by P.

$$P = wA. \bar{x} \quad A = \text{Area of the surface}$$

$$\bar{x} = \text{Depth of C.G. of the surface from the liquid level}$$

### 7.1.8 CENTRE OF PRESSURE

It is defined as the point of application of the resultant of the total pressure on the surface. It is represented by "C".

Idea on total pressure and centre of pressure helps in determination of magnitude and location of total force on vertical sluice gates in dams.

### 7.1.9 DEPTH OF CENTRE OF PRESSURE

It is the distance between the point of action of the total pressure on a immersed plate to the top surface of the liquid.

It is represented by  $\bar{h}$

## 7.1.10 THREE TYPES OF IMMERSED PLANE SURFACE AREA

### 1. Horizontally immersed plane surface (Fig 7.2)

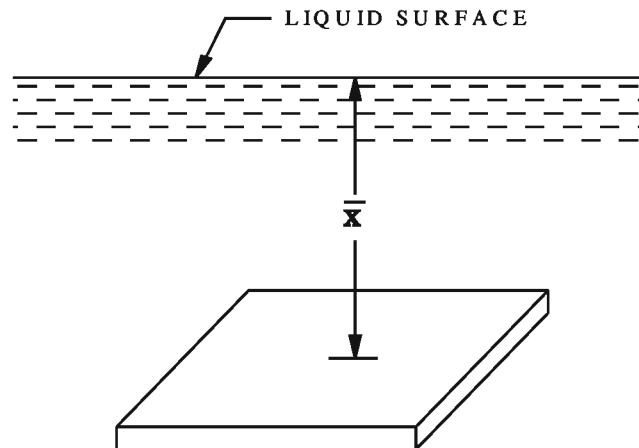

Fig. 7.2 HORIZONTALLY IMMERSED PLANE SURFACE

Depth of centre of pressure  $\bar{h} = \bar{x}$ .

where  $\bar{x}$  = distance of centre of gravity of the horizontal plane surface from the surface of the liquid

### 2. Vertically immersed plane surface (Fig. 7.3)

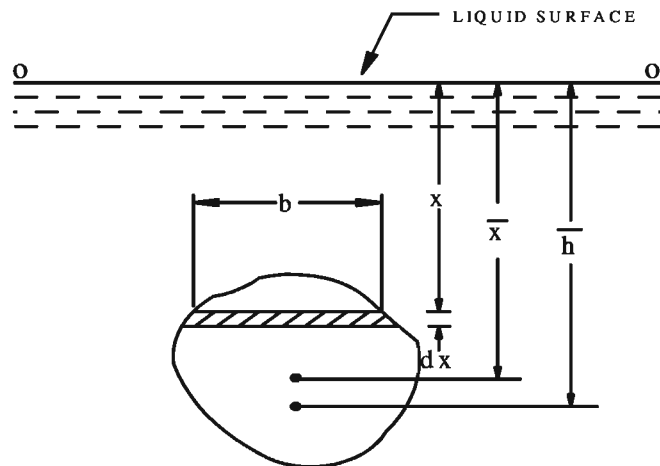

Fig. 7.3 VERTICALLY IMMERSED PLANE SURFACE

Depth of centre of pressure  $\bar{h} = \frac{I_G}{A\bar{x}} + \bar{x}$

Where,  $I_G$  – Moment of inertia of the area about an axis passing through C.G. of the area and parallel to the free surface of the liquid.

$A$  – Area of the plane surface

$\bar{x}$  - Distance of C.G. of the area from the free surface of the liquid.

### 3. Inclined immersed plane surface (Fig 7.4)

Depth of centre of pressure

$$\bar{h} = \frac{I_G \sin^2 \theta}{A\bar{x}} + \bar{x}$$

$\theta =$  Angle of Inclined plane immersed surface with horizontal

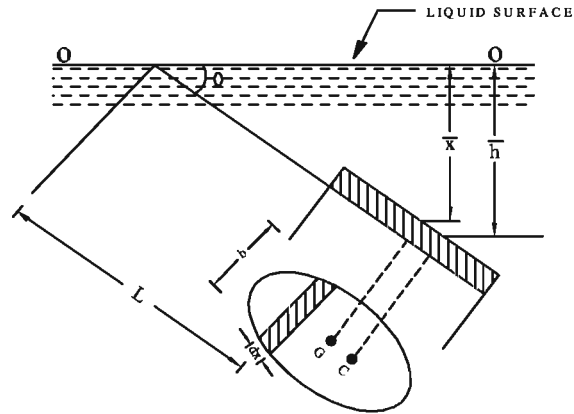

Fig. 7.4 INCLINED IMMERSSED PLANE SURFACE

#### Example 1

Determine the total pressure and depth of centre of pressure from the water level when a square plate of size 2m is immersed vertically in water :

- When the top of the plate coincides with water level
- When the top level of the plate is 2m below the water level.

**Solution:** Area of plate (A) =  $a^2$   
 $= 2^2 = 4\text{m}^2$

$$\text{Moment of inertia } (I_G) = \frac{a^4}{12} = \frac{2^4}{12}$$

$$= 1.33\text{m}^4$$

- a) When top of the plate coincides with water level.

$$\begin{aligned} \text{Total pressure (P)} &= wA\bar{x} & w &= 9810\text{N/m}^3 \\ &= 9810 \times 4 \times 1 \\ &= 39240 \text{ N (or) } 39.24 \text{ kN} \end{aligned}$$

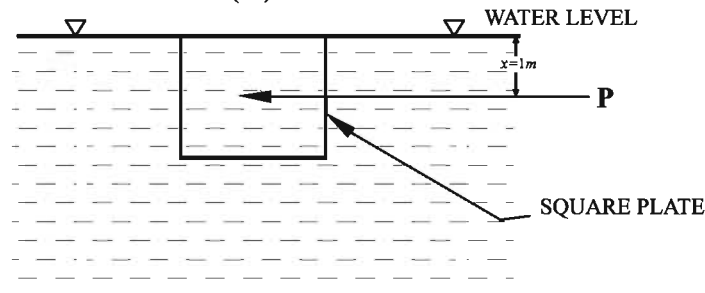

$$\begin{aligned} \text{Depth of centre of pressure } (\bar{h}) &= \frac{I_G}{A\bar{x}} + \bar{x} \\ &= \frac{1.33}{4 \times 1} + 1 \\ &= 1.30\text{m} \end{aligned}$$

- b) When the top level of the plate 2m below the water level

$$\begin{aligned} \text{Total pressure (P)} &= wA\bar{x} & \bar{x} &= 2+1=3\text{m} \\ &= 9810 \times 4 \times 3 \\ &= 117720 \text{ N (or) } 117.72 \text{ kN} \end{aligned}$$

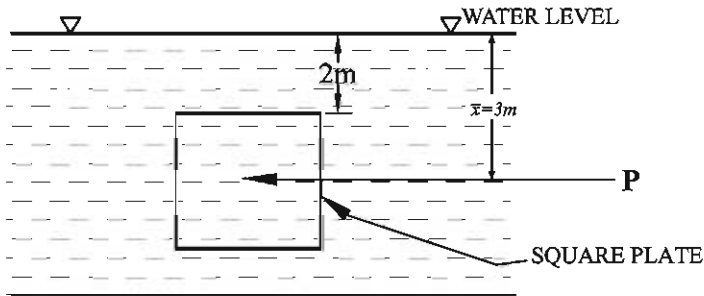

$$\begin{aligned} \text{Depth of pressure } (\bar{h}) &= (\bar{h}) = \frac{I_G}{A\bar{x}} + \bar{x} \\ &= \frac{1.33}{4 \times 3} + 3 \\ &= 3.10 \text{ m} \end{aligned}$$

### Example 2

Determine the total pressure and depth of centre of pressure from the water level when a rectangular plate of size 2m wide and 4m height is immersed vertically in water :

- when the top level of the plate coincides with water level.
- when the top level of the plate is 3m below the water level.

**Solution :** Area of the plate (A) =  $b \times d$   
 $= 2 \times 4$   
 $= 8 \text{ m}^2$

$$\begin{aligned} \text{Moment of inertia } (I_G) &= \frac{bd^3}{12} \\ &= \frac{2 \times 4^3}{12} = 10.7 \text{ m}^4 \end{aligned}$$

- When the top level of the plate coincides with the water level.

$$\begin{aligned} \text{Total pressure } (P) &= wA\bar{x} & w &= 9810 \text{ N/m}^3 \text{ (or)} \\ &= 9.81 \times 8 \times 2 & w &= 9.81 \text{ kN/m}^3 \\ &= 157 \text{ kN} \end{aligned}$$

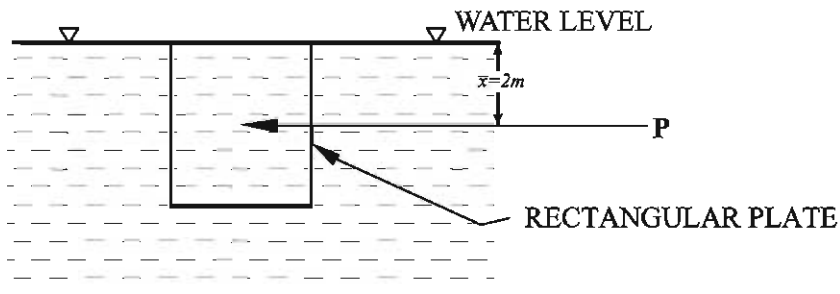

$$\begin{aligned} \text{Depth of centre of pressure } (\bar{h}) &= \frac{I_G}{A\bar{x}} + \bar{x} \\ &= \frac{10.7}{8 \times 2} + 2 \\ &= 2.7 \text{ m} \end{aligned}$$

b) When the top level of the plate is 3m below the water level

$$\begin{aligned} \text{Total pressure (P)} &= wA\bar{x} \\ &= 9.81 \times 8 \times (3+2) \\ &= 392.4 \text{ kN} \end{aligned}$$

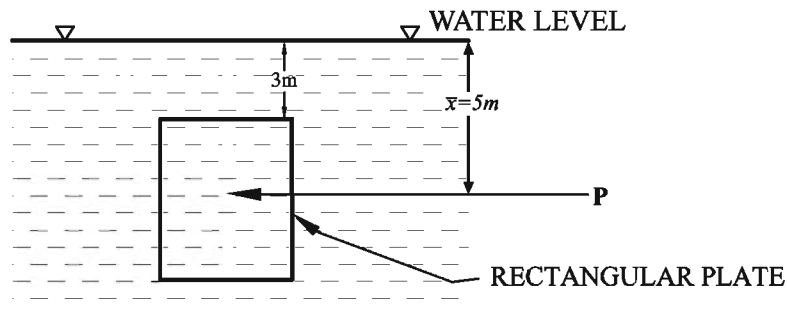

$$\begin{aligned} \text{Depth of centre of pressure } (\bar{h}) &= \frac{I_G}{A\bar{x}} + \bar{x} \\ &= \frac{10.7}{8 \times 5} + (3+2) \\ &= 5.3\text{m} \end{aligned}$$

### Example 3

Determine the total pressure and depth of centre of pressure when a circular plate of diameter 3m is immersed vertically in water.

- When the top of the plate coincides with water level
- When the top of the plate is 0.5m below the water level.

$$\begin{aligned} \text{Solution : Area of the plate (A)} &= \frac{\pi}{4} d^2 \\ &= \frac{3.14}{4} \times 3^2 \\ &= 7.1\text{m}^2 \end{aligned}$$

$$\begin{aligned} \text{Moment of inertia (I}_G) &= \frac{\pi}{64} \times d^4 \\ &= \frac{3.14}{64} \times 3^4 \\ &= 4.0 \text{ m}^4 \end{aligned}$$

- When the top of the plate coincides with water level.

$$\begin{aligned} \text{Total pressure (P)} &= wA\bar{x} \\ &= 9.81 \times 7.1 \times 1.5 \\ &= 104.5\text{kN} \end{aligned}$$

$$w = 9.81 \text{ N/m}^3$$

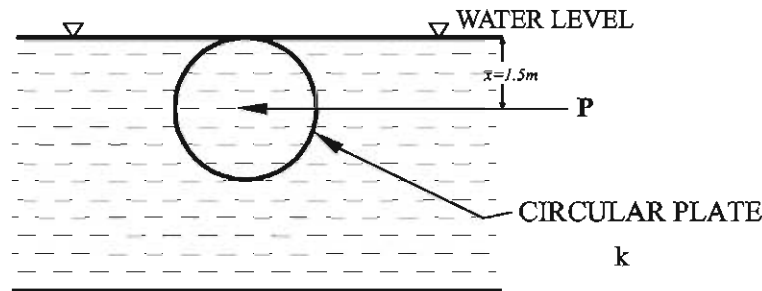

$$\begin{aligned} \text{Depth of centre of pressure } (\bar{h}) &= \frac{I_G}{A\bar{x}} + \bar{x} \\ &= \frac{4}{7.1 \times 1.5} + 1.5 \\ &= 1.9\text{m} \end{aligned}$$

b) When the top of the plate is 0.5 m below the water level

$$\begin{aligned} \text{Total pressure (P)} &= wA\bar{x} \\ &= 9.81 \times 7.1 \times (1.5 + 0.5) \\ &= 139.3 \text{ kN} \end{aligned}$$

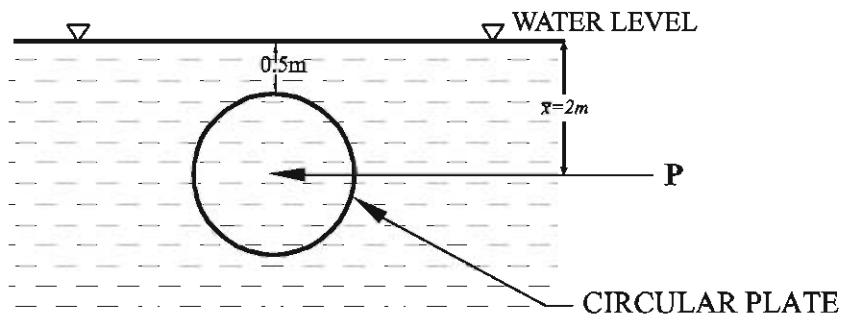

$$\begin{aligned} \text{Depth of centre of pressure } (\bar{h}) &= \frac{I_G}{A\bar{x}} + \bar{x} \\ &= \frac{4}{7.1 \times 2} + 2 \\ &= 2.3\text{m} \end{aligned}$$

### 7.1.11 FLOW THROUGH ORIFICE

**Orifice:** An orifice is a small opening of any cross-section (circular, triangular, rectangular etc.) in the wall or base of a vessel through which the fluid is flowing. Orifice is used to measure the rate of flow of fluid from the vessel, usually a tank.

### 7.1.12 CLASSIFICATION OF ORIFICE

1. According to size:
  - (i) Small orifice
  - (ii) Large orifice

## 2. According to shape

- (i) Circular orifice
- (ii) Rectangular orifice
- (iii) Triangular orifice
- (iv) Square orifice

## 3. According to shape of and edge:

- (i) Sharp edged orifice
- (ii) Bell Mouthed orifice.

## 4. According to nature of discharge:

- (i) Free discharging orifice
- (ii) Drowned or submerged orifice

**The submerged orifices are classified into two types :**

- (a) Fully submerged orifices.
- (b) Partially submerged orifices.

### 7.1.13 VENA CONTRACTA

When liquid flows out from a tank under pressure through an orifice, the diameter of the jet of liquid will be equal to the diameter of the orifice. But the diameter of the jet and liquid contracts at a particular place away from the orifice and then expands again. The point at which the diameter of the jet contracts to the maximum is called “Vena Contracta”.

### 7.1.14 HYDRAULIC CO-EFFICIENTS

The hydraulic co-efficients are

- (i) Co-efficient of contraction  $C_c$
- (ii) Co-efficient of velocity  $C_v$
- (iii) Co-efficient of discharge  $C_d$

#### (i) Coefficient of contraction $C_c$ :

The ratio of the area of the jet at vena-contracta to the area of the orifice is known as coefficient of contraction.

$$C_c = \frac{a_c}{a} \qquad C_c = \text{co-efficient of contraction}$$

$a_c$  - area of jet at vena contracta

$a$  - area of orifice

The value of  $C_c$  varies from 0.61 to 0.69.



(ii) Coefficient of velocity  $C_v$  :

The ratio of actual velocity ( $V$ ) of the jet at vena contracta to the theoretical velocity ( $V_{th}$ ) of jet is known as co-efficient of velocity.

$$C_v = \frac{\text{Actual velocity of jet at vena contracta}(V)}{\text{Theoretical velocity } (V_{th})}$$

$$C_v = \frac{V}{\sqrt{2gH}}$$

Where,  $V$  - actual velocity

$H$  - head under which the fluid flows out of the orifice.

The value of  $C_v$  varies from 0.95 to 0.99.

(iii) Coefficient of discharge  $C_d$  :

The ratio of actual discharge ( $Q$ ) through an orifice to the theoretical discharge ( $Q_{th}$ ) is known as coefficient of discharge.

$$C_d = \frac{\text{Actual discharge } (Q)}{\text{Theoretical discharge}(Q_{th})}$$

$$= \frac{\text{Actual area} \times \text{actual velocity}}{\text{Theoretical area} \times \text{theoretical velocity}}$$

$$C_d = C_c \times C_v$$

The value of  $C_d$  varies from 0.61 to 0.65.

### 7.1.15 FLOW THROUGH AN ORIFICE

Consider a tank fitted with a circular orifice in one of its sides as shown in figure 7.5. Let  $H$  be the head of the liquid flowing through the orifice. The liquid flows as a jet whose area of cross-section is less than that of orifice. The area of jet of fluid goes on decreasing and at a section  $C_c$ , the area is minimum

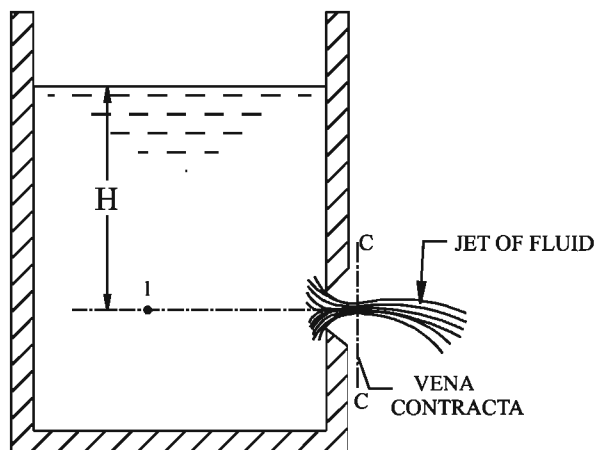

Fig. 7.5 TANK WITH AN ORIFICE

This section is approximately at a distance of half of the diameter of the orifice. At this section, the streamlines are straight and parallel to each other and perpendicular to the plane of the orifice. This section is called as vena contracta.

Beyond this section, the jet diverges and is attracted in the downward direction by the gravity.

Applying Bernoulli's theorem.

$$\frac{p_1}{\rho g} + \frac{V_1^2}{2g} + Z_1 = \frac{p_2}{\rho g} + \frac{V_2^2}{2g} + Z_2$$

$$Z_1 = Z_2$$

$$\frac{p_1}{\rho g} + \frac{V_1^2}{2g} = \frac{p_2}{\rho g} + \frac{V_2^2}{2g}$$

$$\frac{p_1}{\rho g} = H$$

$$\frac{p_2}{\rho g} = 0 \text{ (atmospheric pressure)}$$

$V_1$  is very small in comparison to  $V_2$  and hence  $V_1$  is neglected.

$$\therefore H + 0 = 0 + \frac{V_2^2}{2g}$$

$$\text{Theoretical velocity } V_2 = \sqrt{2gH}$$

## 7.2 FLOW THROUGH PIPES

### 7.2.1 PIPE

A pipe is a closed conduit (generally of circular section) which is used for carrying fluids under pressure. The flow in a pipe is termed pipe flow only when the fluid completely fills the cross section and there is no free surface of fluid.

### 7.2.2 TYPES OF FLOW

1. Laminar flow / Viscous flow
2. Turbulent flow / Non - viscous flow

#### Laminar flow:

A flow is said to be viscous or laminar if the Reynolds number is less than 2000 and the fluid flows in layers. Each layer of fluid slides smoothly over the adjacent layer. The path of individual fluid particles do not cross each other. Laminar flow occurs when the velocity of flow is less and viscosity is high.

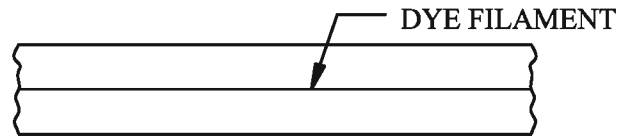

Fig. 7.6 (a) LAMINAR FLOW

**Turbulent flow:**

Turbulent flow is that type of flow in which the fluid particles move in a zig-zag way. Due to the movement of fluid particles in a zig -zag way, the eddies formation takes place which are responsible for high energy loss.

If the Reynolds number is more than 4000, it is called turbulent flow.

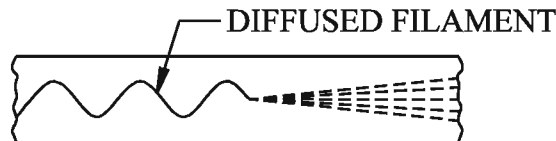

Fig. 7.6 (b) TURBULENT FLOW

A laminar flow changes to turbulent flow when,

- (i) Velocity is increased
- (ii) Diameter of pipe is decreased
- (iii) The viscosity of fluid is decreased.

If the Reynolds number is between 2000 to 4000, then the flow is called Transition flow, where the flow changes from laminar to turbulent.

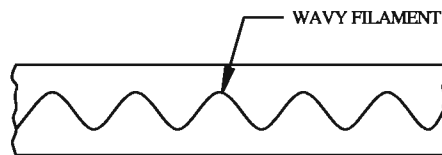

Fig. 7.6 (c) TRANSITION FLOW

**7.2.3 CRITICAL VELOCITY :- (V<sub>c</sub>)**

The velocity of flow at which the flow changes from laminar to turbulent is known as “critical velocity”. It is denoted by “V<sub>c</sub>”. The mathematical expression for critical velocity is

$$V_c = \sqrt{g \times h_c}$$

h<sub>c</sub> = critical depth

**Types of critical velocity:**

- 1. Lower critical velocity
- 2. Upper critical velocity

**1. Lower critical velocity**

In a continuous flow, the velocity calculated at the starting point where flow changes from laminar to transition flow is called lower critical velocity.

**2. Upper critical velocity**

In a continuous flow, the velocity calculated at the point where the flow completely changes from transition to turbulent flow is called upper critical velocity.

## 7.2.4 HYDRAULIC GRADIENT LINE :

It is defined as the line which gives the sum of pressure head ( $p/w$ ) and datum head ( $Z$ ) of a flowing fluid in a pipe with respect to some reference line or it is the line which is obtained by joining the top of all vertical ordinates, showing the pressure head ( $p/w$ ) of a flowing fluid in a pipe from the centre of the pipe.

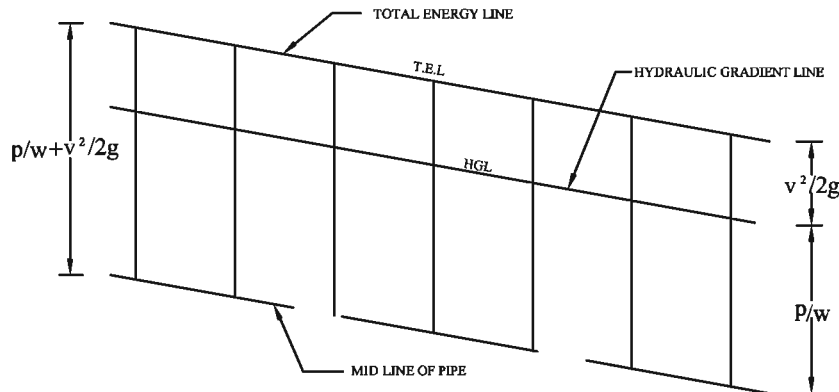

Fig. 7.7 HYDRAULIC GRADIENT LINE

## 7.2.5 TOTAL ENERGY LINE

It is defined as the line which gives the sum of pressure head ( $p/w$ ) + datum head ( $z$ ) and velocity head ( $v^2/2g$ ) of a flowing fluid in a pipe with respect to some reference line.

$$\text{Total energy head} = \left( \frac{p}{w} + \frac{v^2}{2g} + Z \right)$$

## 7.2.6 LOSS OF HEAD:

When a fluid is flowing through a pipe, the fluid experiences some resistance due to which some of the energy of fluid is lost. This is called as loss of head.

### Types of losses:

- 1) Major loss
- 2) Minor losses

#### 1. Major loss or loss of head due to friction:

Flowing liquid in a pipe experiences some resistance to its motion due to its contact with the inner surface of the pipe. This resistance is due to friction offered by the rough surface of the pipe to the flow. In overcoming this frictional resistance some energy is lost by the flowing fluid which is called as loss due to friction. This loss is much more when compared to all other losses in a pipe flow. Hence it is also called as “major loss”.

Major loss is due to friction and it is calculated by the following :

1. Darcy Weisbach formula
2. Chezy's formula

## 2. Minor losses:

In a pipe flow, at entrance, at exit, at sudden enlargement of pipe, at sudden contraction of pipe, due to obstruction, due to bends and due to special pipe fittings, loss of energy occurs. These losses are very less in magnitude and hence called as “minor losses”.

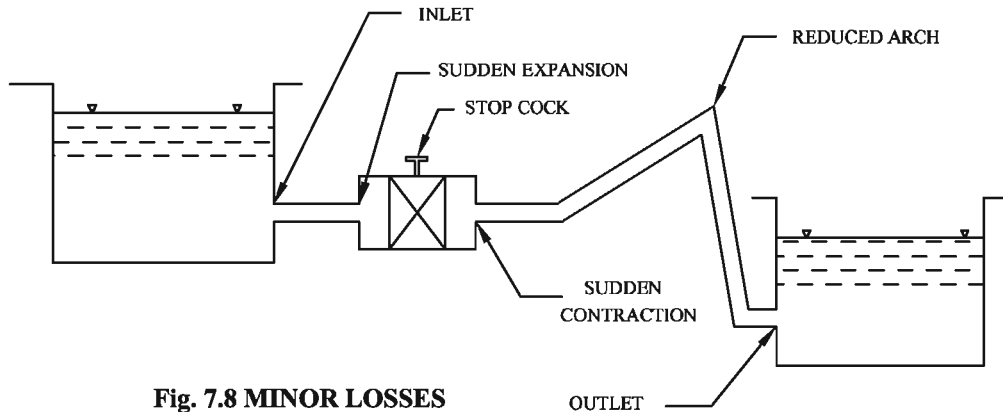

Fig. 7.8 MINOR LOSSES

### 7.2.7 WETTED PERIMETER(P):

In general, during the pipe flow the liquid wets the entire circumference of the pipe and flows. The wetted circular portion of the pipe is called the wetted perimeter.

In a circular section, if the water is flowing fully,  
the wetted perimeter,  $P = \text{Circumference of the circle}$   
 $= \pi d$

where 'd' is the diameter of pipe

### 7.2.8 HYDRAULIC MEAN DEPTH(m):

The ratio between the area of flow and the wetted perimeter is called hydraulic mean depth or hydraulic radius and is denoted by “m”

$$\begin{aligned} \text{Hydraulic mean depth (m)} &= \frac{\text{Area of flow (A)}}{\text{wetted perimeter(P)}} \\ &= \frac{A}{P} = \frac{A}{\pi d} \\ &= \frac{\pi d^2 / 4}{\pi d} \\ m &= d / 4 \end{aligned}$$

### 7.2.9 CHEZY'S FORMULA USED FOR THE DETERMINATION OF LOSS OF HEAD DUE TO FRICTION:

Mean velocity of flow,  $V = C \sqrt{mi}$  we get

$V$  = mean velocity of flow

$C$  = Chezy's constant

$m$  = Hydraulic mean depth

$i$  = (bed slope)

$$\text{Also } i = \frac{h_f}{l}$$

loss of head due to friction,

$$h_f = \frac{v^2 l}{C^2 m}$$

### 7.2.10 DARCY'S FORMULA FOR FINDING LOSS OF HEAD DUE TO FRICTION:

$$h_f = \frac{flv^2}{2gd} \text{ meter of water}$$

$h_f$  - loss of head due to friction

$f$  - co-efficient of friction

$l$  - length of pipe

$V$  - mean velocity of flow

$g$  -  $9.81\text{m/s}^2$

$d$  - diameter of pipe

### 7.2.11 DARCY'S FORMULA FOR FINDING DISCHARGE:

$$h_f = \frac{fLV^2}{2gd}$$

Discharge  $Q = A \times V$

$$V = Q/A$$

$$V^2 = Q^2/A^2$$

$$V^2 = \frac{Q^2}{\left\{ \frac{\pi d^2}{4} \right\}^2}$$

$$V^2 = \frac{Q^2}{\left\{ \frac{\pi^2 d^4}{16} \right\}} = \frac{16Q^2}{\pi^2 d^4}$$

Applying Darcy's formula,

$$h_f = \frac{fLV^2}{2gd}$$

$$= \frac{fL \left( \frac{16Q^2}{\pi^2 d^4} \right)}{2gd}$$

$$= \frac{16fLQ^2}{2g\pi^2 d^5}$$

$$h_f = \frac{fLQ^2}{12d^5}$$

**Example 4**

Water flows through a pipe of diameter 150 mm with a velocity 2.4 m/s. If the coefficient of friction is 0.02. Find the head loss due to friction for a length of 100m

Solution:

Diameter of pipe,  $d$  = 150 mm

Length of pipe,  $l$  = 100 m

Velocity of water,  $v$  = 2.4 m/s

Coefficient of friction,  $f$  = 0.02

Head loss due to friction,  $h_f$  = Required

Head loss due to friction,

$$h_f = \frac{fV^2}{2g.d} = \frac{0.02 \times 100 \times (2.4)^2}{2 \times 9.81 \times 0.15}$$

$$h_f = 3.91 \text{ m}$$

**Example 5**

Water flows through a pipe of diameter 300 mm and having length 400 m. It discharges water at 191 litres per second. Find the head loss due to friction. Assume coefficient of friction as 0.02.

Solution:

Diameter of pipe, (d) = 300 mm = 0.30 m

Length of pipe, (l) = 400 m

Discharge, (Q) = 191 l/s = 0.191 m<sup>3</sup>/s

Coefficient of friction, (f) = 0.02

Find: Head loss due to friction,  $h_f$  = Required

$$\begin{aligned} h_f &= \frac{fQ^2}{12d^5} \\ &= \frac{0.02 \times 400 \times (0.191)^2}{12 \times (0.30)^5} \\ &= 10.00 \text{ m.} \end{aligned}$$

Head loss due to friction ( $h_f$ ) = 10 m

**Example 6**

The pressure difference between two ends of pipe is 1.5m, the diameter and length of pipes are 300 mm and 250 m respectively. Determine the discharge of flow. Assume coefficient of friction  $f=0.04$ .

Solution:

Diameter of pipe,  $d$  = 300mm = 0.3m

Length of pipe  $l$  = 250m

Pressure difference,  $h_f$  = 1.5m

Coefficient of friction,  $f$  = 0.04

**Find:** Discharge (Q) = Required

$$h_f = \frac{f l Q^2}{12 d^5}$$
$$Q = \sqrt{\frac{12 d^5 \times h_f}{f l}}$$
$$= \sqrt{\frac{12 \times (0.3)^5 \times 1.5}{0.04 \times 250}}$$
$$= 0.07 \text{ m}^3/\text{s}$$

Discharge Q = 0.07 m<sup>3</sup>/s

### Example 7

A 150 mm diameter and 60 m long horizontal pipe is connected at the base of the tank and it is open at the top. 3m depth of water is filled in the tank above the centre of pipe. Take friction factor as 0.04 and determine the quantity of discharge from the pipe (neglect minor losses).

Solution : Diameter of pipe,  $d$  = 150 mm = 0.15 m  
Length of pipe,  $l$  = 60 m  
Loss of head,  $h_f$  = 3 m  
Friction factor,  $f$  = 0.04

Discharge of water Q = Required

According to Darcy's formula  $h_f = \frac{f l Q^2}{12 d^5}$

$$Q = \sqrt{\frac{h_f 12 d^5}{f l}}$$
$$= \sqrt{\frac{3 \times 12 \times 0.15^5}{0.04 \times 60}}$$
$$= 0.033 \text{ m}^3/\text{sec}$$

Quantity of discharge Q = 0.033 m<sup>3</sup>/sec

### Example 8

In a pipe of diameter 50mm and length 20m water is flowing at a velocity of 3m/s. Find the head loss due to friction. Assume Chezy's constant C=60.

**Solution:**

Diameter of pipe,  $d$  = 50mm = 0.05m  
Length of pipe,  $l$  = 20m  
Velocity of flow,  $V$  = 3m/s  
Chezy's constant,  $C$  = 60  
 $h_f$  = Required



$$V = C\sqrt{mi}$$

Head loss  $h_f = \frac{V^2 l}{C^2 m}$

$$m = d/4 = \frac{0.05}{4} = 0.0125m$$

$$h_f = \frac{3^2 \times 20}{60^2 \times 0.0125} = \frac{180}{45}$$

$$h_f = 4m$$

**Example 9.**

A pipe is connecting two tanks having pressure difference of 3 m. The diameter and length of pipe are 300 mm and 600 m respectively. Determine the velocity of flow. Assume Chezy's constant  $C = 60$ .

**Solution :**

Diameter of pipe  $d = 300 \text{ mm} = 0.30 \text{ m}$

Length of pipe  $l = 600 \text{ m}$

Pressure head difference,  $h_f = 3 \text{ m}$

Chezy's constant  $C = 60$

Velocity of flow  $V = C\sqrt{mi}$

$$m = d/4 = \frac{0.30}{4} = 0.075m$$

$$\left( i = \frac{h_f}{L} = \frac{3}{600} = 0.005m \right)$$

$$V = C\sqrt{mi}$$

$$= 60\sqrt{0.075 \times 0.005}$$

$$= 60\sqrt{0.000375}$$

$$= 1.2m/s$$

Velocity of flow,  $V = 1.2 \text{ m/s}$

## 7.3 FLOW THROUGH CHANNELS

A channel is defined as a passage (natural or artificial) in which liquid flows with its upper surface exposed to atmosphere.

The velocity changes at every point over the depth of the channel. Hence, average velocity of flow is taken into consideration for design of all channels. The channel is designed by considering uniform flow, uniform discharge, depth of flow, velocity, slope and considering cross-sectional area as constant. The flow is due to gravity in open channels. The flow conditions are greatly influenced by the slope of the channel. For the given cross-section and gradient if the discharge is maximum, such a cross section is called the most economical section.

### 7.3.1 AREA OF CHANNEL(A):

The cross-sectional area of the flow of water in a channel is taken as area of channel. It is represented by 'A'. The unit is m<sup>2</sup>.

### 7.3.2 WETTED PERIMETER(P):

When the water flows in a channel, wetted perimeter is the length of the sides in contact with water. It is denoted as "P". The unit for wetted perimeter is metre.

Its unit is "m".

### 7.3.3 HYDRAULIC MEAN DEPTH(m):

It is the ratio of cross-sectional area to the wetted perimeter of the channel. It is represented by the symbol 'm'. Unit for hydraulic mean depth is "metre".

$$m = \frac{\text{Cross-sectional Area}}{\text{Wetted perimeter}} = \frac{A}{P}$$

$$m = \frac{A}{P}$$

### 7.3.4. DISCHARGE THROUGH CHANNELS USING CHEZY'S FORMULA:

According to Chezy's formula,

$$\text{Velocity of flow } V = C\sqrt{mi}$$

Discharge through the channel

$$Q = A \times V$$

$$Q = A \times C\sqrt{mi}$$

Q = Discharge

A = Area of cross-section of the channel

C = Chezy's constant, which depends on the roughness.

m = hydraulic mean depth

i = bed slope.

**7.3.5. FORMULAE FOR FINDING AREA, WETTED PERIMETER AND HYDRAULIC MEAN DEPTH:**

Parameter	Rectangle	Trapezoidal
Area	$A = b \times d$	$A = (b + nd) d$
Wetted Perimeter	$P = b + 2d$	$P = b + 2d\sqrt{1 + n^2}$
Hydraulic Mean depth	$m = \frac{A}{P} = \frac{bd}{b + 2d}$	$m = \frac{A}{P} = \frac{(b + nd)d}{b + 2d\sqrt{1 + n^2}}$

**1. Rectangular section**

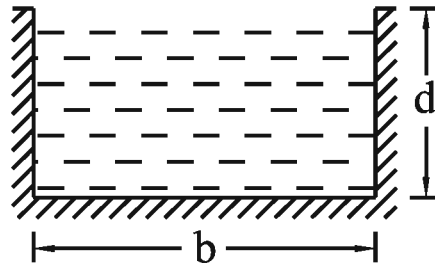

**2. Trapezoidal Section:**

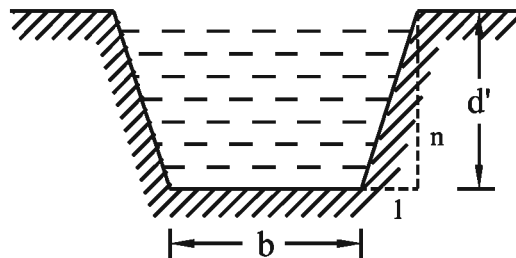

**Example 10**

Determine the rate of flow in a rectangular channel 4m wide running full for uniform flow of a depth of 1m. The channel is having a bed slope of 1 in 1000. Assume Chezy's constant C= 50.

**Solution:**

- Width of the rectangular channel,  $b = 4 \text{ m}$
- Depth of flow,  $d = 1 \text{ m}$
- bed slope,  $i = 1 \text{ in } 1000$
- Chezy's constant  $C = 50$
- Required : Discharge  $Q,$

Area of flow,

$$\begin{aligned}
 A &= b \times d \\
 &= 4 \times 1 \\
 &= 4\text{m}^2
 \end{aligned}$$

Wetted perimeter

$$\begin{aligned}
 &= b + 2d \\
 P &= 4 + 2(1) \\
 P &= 6\text{m}
 \end{aligned}$$

Hydraulic mean depth,

$$m = \frac{A}{P}$$

$$= \frac{4}{6} = 0.67m$$

$$\text{Discharge of flow, } Q = AC\sqrt{mi}$$

$$= 4 \times 50 \sqrt{0.67 \times \frac{1}{1000}}$$

$$= 5.2 \text{ m}^3/\text{s.}$$

$$\therefore \text{Discharge, } Q = 5.2 \text{ m}^3 / \text{sec}$$

### Example 11

A channel of trapezoidal section has bed width 1m and bed slope is 1/1600. If the depth of flow is 4m & side slopes of the channel are 1:1. determine the discharge carried by the channel. Assume Chezy's constant  $C=50$

**Solution :**

Depth of flow, $d$	=	4m
Bed width, $b$	=	1m
Slope (1:n)	=	1:1
$n$	=	1
Bed slope (i)	=	1/1600
Chezy's constant $C$	=	50
Discharge, $Q$	=	Required

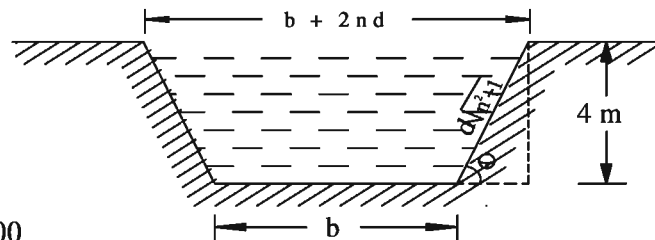

Area of trapezoidal section,  $A = (b+nd) d$

$$A = [1 + (1 \times 4)] \times 4$$

$$= 20 \text{ m}^2$$

Wetted perimeter,  $P$

$$= b + 2d \sqrt{1+n^2}$$

$$= 1 + (2 \times 4) \sqrt{1+1^2}$$

$$= 12.31 \text{ m}$$

Hydraulic mean depth,  $m$

$$= \frac{A}{P}$$

$$= \frac{20}{12.31} = 1.62m$$

Discharge,  $Q$

$$= A.C \sqrt{mi}$$

$$= 20 \times 50 \sqrt{1.62 \times \frac{1}{1600}}$$

$$= 31.8 \text{ m}^3/\text{s.}$$

### 7.3.6 MOST ECONOMICAL SECTION FOR CHANNELS:

Most economical section is also called the best section or the most efficient section as the discharge passing through a most economical section of channel for a given cross-sectional area(A), bed slope (i) and a resistance coefficient is maximum. The discharge, Q is given by

$$Q=AC\sqrt{mi}$$
$$=AC\sqrt{\frac{A \times i}{P}}$$

## 7.4 HYDRAULIC MACHINERY

### 7.4.1 PUMPS:

A pump is a device which transfers energy from impeller to the fluid. It converts the mechanical energy to hydraulic energy. It is used to lift water from a lower level to higher level. The study of various types of pumps helps in knowing the working principle and characteristics of pumps. It also helps in the selection of pumps.

### 7.4.2 CLASSIFICATION OF PUMPS:

- 1) Positive displacement pumps
- 2) Rotodynamic pumps

#### 1. Positive displacement pumps

- i) Reciprocating pump
- ii) Rotary pump

#### i. Reciprocating pump

- a) Single Acting reciprocating pump
- b) Double Acting reciprocating pump

#### ii. Rotary pump

- a) Gear pump
- b) Van pump

#### 2. Roto dynamic pumps

- i) Centrifugal pump
- ii) Axial pump

### 7.4.3 TYPES OF PUMPS

- 1) Reciprocating pump
- 2) Centrifugal pump
- 3) Jet pump
- 4) Deep well pump
- 5) Submersible type deep well pump
- 6) Gear pump

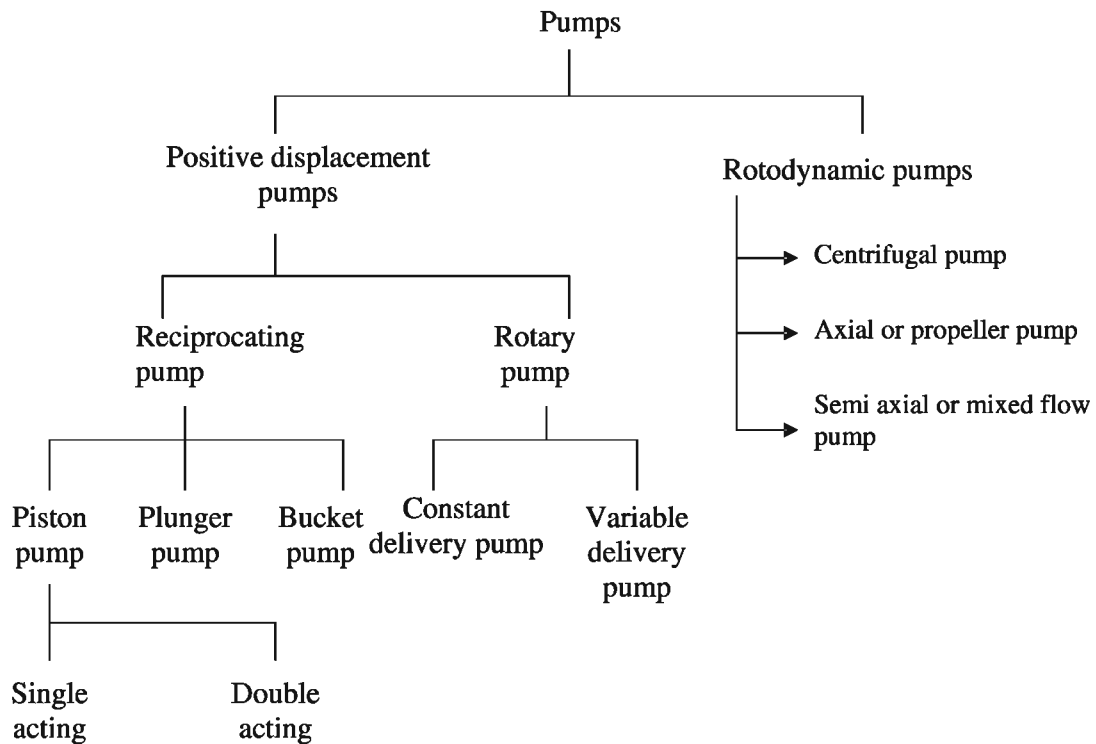

**1. SINGLE ACTING RECIPROCATING PUMP:**

**Structure:**

A piston or a plunger moves to and fro (reciprocates) in a stationary cylinder, alternatively drawing in and pushing out liquid through valves. The suction and delivery pipes are connected to cylinder where the suction valve and delivery valve are connected respectively. Piston rod and connecting rod are connected to shaft through crank. The revolving crank with an eccentricity and the connecting rod completes the arrangement. The length of travel of the piston is known as the stroke, which should be equal to the diameter of the rotating crank wheel.

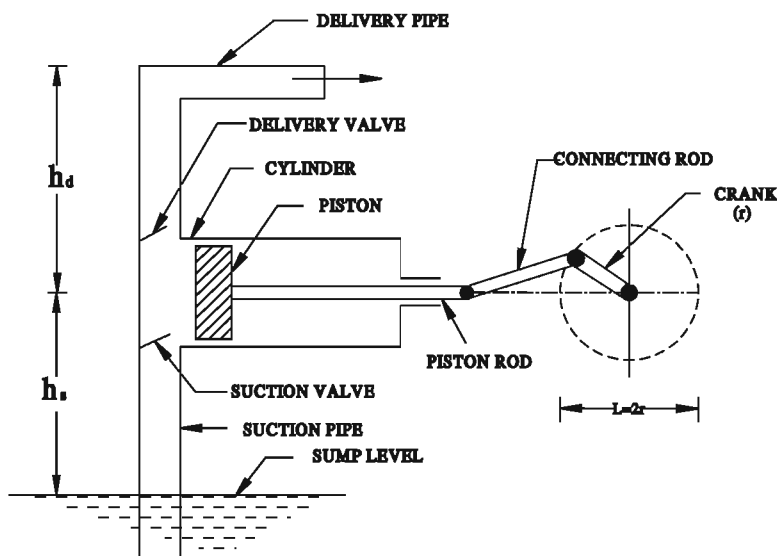

**Fig. 7.9 SINGLE ACTING RECIPROCATING PUMP**

### Working principle :

As the piston moves to the right, the pressure inside the cylinder drops below atmospheric. This causes the delivery valve to close and the suction valve to admit the liquid into the cylinder from the sump forced by the atmospheric pressure. It is the suction stroke. when the piston returns, the increased pressure closes the suction valve and opens the delivery valve to force the liquid out into the delivery pipe causing the delivery stroke. One rotation of the crank corresponds to one cycle of operation. The suction and delivery strokes are performed for every cycle and discharge.

The speed of the crank shall have to be low so that the liquid does not lag behind the piston during the suction stroke. A pump is single acting if there is only one suction or delivery stroke per cycle.

## 2. DOUBLE ACTING RECIPROCATING PUMP

### Working principle :

It is similar to single acting reciprocating pump. It has two suction and two delivery pipes and valves on either side of the piston connected to the cylinder.

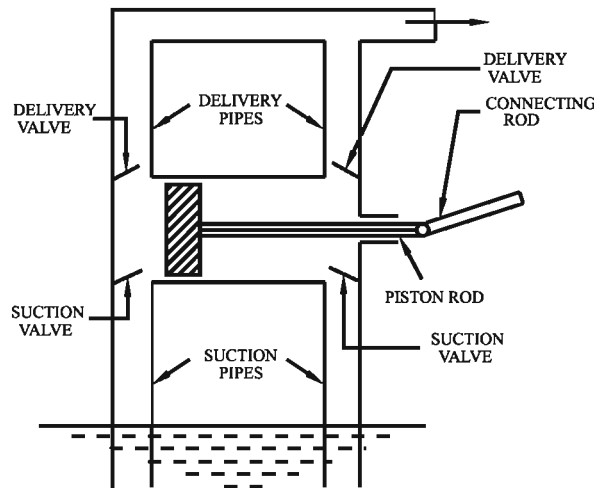

Fig. 7.10 DOUBLE ACTING RECIPROCATING PUMP

When the piston moves, water is collected on one side and discharged on other side, so that water is discharged continuously.

There are two suction strokes and delivery strokes during each revolution of the crank. Thus, water is supplied uniformly in the delivery pipe and the quantity of discharge is double that of single acting reciprocating pump.

Discharge of pump } = volume of water delivered in one revolution x No. of revolutions  
per second } per second

$$Q = \frac{2ALN}{60}$$

A – Area of cross-section of the cylinder.

L – Stroke length.

N – Speed of the pump (*rpm*)

#### 7.4.4 AIR VESSELS:

An air vessel is used to rectify the fluctuation in the flow of a reciprocating pump. An air vessel is fixed near the cylinder either in the suction pipe or delivery pipe or both. It is a chamber with full of air under pressure with an opening at the bottom. Water can enter either enter inside or exit outside the air vessel through the opening.

It is used to

- (i) obtain a continuous supply of water at uniform rate.
- (ii) save a considerable amount of work
- (iii) run the pump at a high speed without separation.

#### WORKING PRINCIPLE OF AIR VESSELS:

When the air vessel is fitted to the delivery pipe during the first half of delivery stroke, the piston moves with acceleration and forces the water into the delivery pipe with a velocity more than the mean velocity. The quantity of water in excess of the mean discharge will flow into the air vessel. During the second half of the delivery stroke the piston moves with retardation. The water already stored in the air vessel will start flowing into the delivery pipe and the velocity of flow in the delivery pipe beyond the point at which air vessel is fitted will be equal to the mean velocity. Hence the rate of flow of water in the delivery pipe will be uniform.

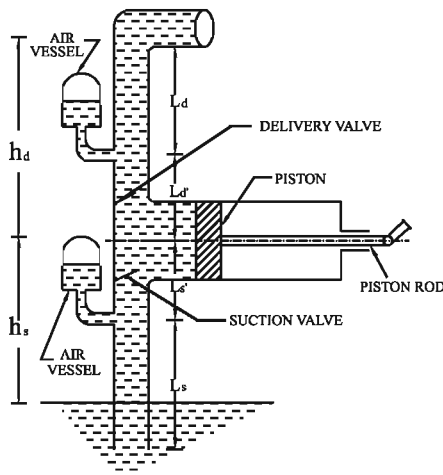

Fig. 7.11 WORKING PRINCIPLE OF AIR VESSELS

#### 7.4.5 COMPARISON BETWEEN SINGLE ACTING AND DOUBLE ACTING RECIPROCATING PUMPS:

Sl. No.	Single acting reciprocating pump	Double acting reciprocating pump
1	The flow is discontinuous	The flow is continuous
2	The water emerging out is less	The water emerging out is twice that of water flowing out in single acting reciprocating pump
3	The water is filled only on one side of the piston	The water is filled on both sides of the piston
4	The efficiency is less	The efficiency is more



### 7.4.6 CENTRIFUGAL PUMP

A hydraulic machine which converts the mechanical energy into the pressure energy by means of centrifugal force is called centrifugal pump.

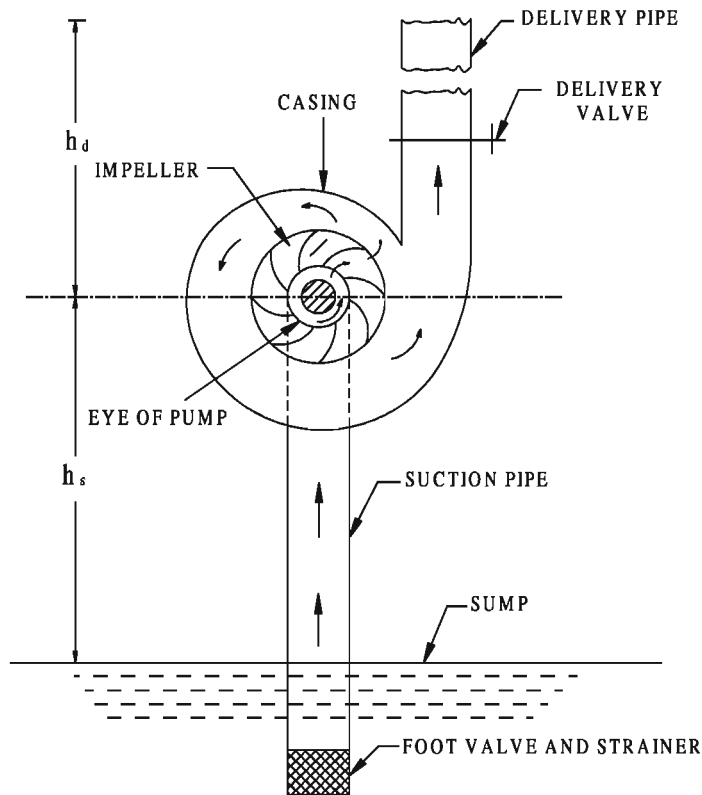

**Fig. 7.12 MAIN PARTS OF CENTRIFUGAL PUMP**

#### **Components of a centrifugal pump:**

- 1) Rotar (or) Impeller
  - 2) Casing
  - 3) Strainer
  - 4) Suction pipe
  - 5) Foot valve
  - 6) Delivery pipe
  - 7) Delivery valve
  - 8) Prime mover.
1. **ROTAR (or) IMPELLER** : It is like the heart of the pump. It is a rotating device with so many vanes in its outer portion. It consists of series of curved vanes fitted between two circular discs.

2. **CASING:** The path of water around the impeller is called casing. Casing consists of air holes and priming funnel. Area of this casing starts narrow and enlarges continuously so that the area is not uniform.
3. **SUCTION PIPE:** The pipe whose lower end is dipped into sump or well is called suction pipe. This pipe goes up to the entrance of the pump from the well or the sump. Water is drawn into the pump from the sump or well through this suction pipe.
4. **STRAINER:** It is fitted at the lower end of suction pipe. It is useful in avoiding the entry of floating bodies/debris inside the pump.
5. **FOOT VALVE:** It is fitted on the upper part of the strainer. As it is a one way valve (or) non-return valve water can only enter and not allowed to move downwards. Priming is necessary only when leakage takes place in the foot valve.
6. **DELIVERY PIPE:** The pipe through which the water pumped from the well is delivered is called delivery pipe.
7. **DELIVERY VALVE:** The rate of water is regulated by a delivery valve fitted close to the pump on its delivery side.
8. **PRIME MOVER:** It is an electric motor (or) oil Engine used to drive the pump.

#### **PRIMING:**

Priming of a centrifugal pump means the operation in which the suction pipe, casing of the pump and a portion of the delivery pipe up to the delivery valve is completely filled up from outside source with the liquid to be raised before starting the pump, thus the air from these parts of the pump is removed and filled with the liquid to be raised.

#### **WORKING PRINCIPLE:**

Before starting the pump, delivery valve should be closed. After the impeller gets its normal speed delivery valve is opened. As the impeller rotates continuously the stored water and entering water of the casing gets centrifugal head. So water is delivered with high pressure.

#### 7.4.7 COMPARISON OF CENTRIFUGAL PUMP AND RECIPROCATING PUMP

S.No	Centrifugal pump	Reciprocating pump
1	The assembly of the pump is not difficult.	The assembly of the pump is difficult because it consists of many parts.
2	The weight of the centrifugal pump is less.	The weight of the reciprocating pump is more.
3	It does not require more floor area or a strong foundation to fix the pump.	It requires more floor area and a strong foundation to fix/erect the pump.
4	It gives high flow percentage and works with low head	It gives low flow percentage and works with high head
5	Wear is less	Wear is more
6	The maintenance cost is less	The maintenance cost is more
7	It is used to lift/operate the polluted water also.	It does not work / operate when polluted water is used.
8	Working speed is high	Working speed is less
9	Priming is necessary	Priming is not necessary
10	Air vessel is not required	Air vessel is required
11	Efficiency of the pump is less	Efficiency of the pump is more
12	More attention is not required while working	More attention is required while working.
13	The flow is continuous	The flow is discontinuous in single acting reciprocating pump

## Part A

Choose the correct Answer

(1 mark each)

- 1) The property of fluid to move from one place to another place is \_\_\_\_\_  
a) liquid                      b) fluid                      c) water                      d) gas
- 2) The unit of density is \_\_\_\_\_  
a)  $\text{kg/m}^3$                       b)  $\text{N/mm}$                       c)  $\text{N-S/m}^3$                       d)  $\text{N/mm}^2$
- 3) The density of pure water is \_\_\_\_\_  
a)  $1000 \text{ kg/m}^3$                       b)  $1000 \text{ kg/m}^2$                       c)  $1000 \text{ kg-m}^4$                       d)  $100 \text{ kg/m}^2$
- 4) The pressure head is \_\_\_\_\_  
a)  $\frac{M \cdot g}{W}$                       b)  $\frac{M}{W}$                       c)  $\frac{A}{W}$                       d)  $\frac{P}{W}$
- 5) The diameter of jet is \_\_\_\_\_ when as compared to the diameter of hole  
a) varied                      b) equal                      c) small                      d) large
- 6) The flow of a liquid in different path in a pipe is called \_\_\_\_\_  
a) turbulent flow                      b) laminar flow                      c) viscous flow                      d) uniform flow
- 7) When the flow changes from transition to turbulent the velocity of flow is called \_\_\_\_  
a) turbulent velocity                      b) critical velocity                      c) upper critical velocity  
d) lower critical velocity
- 8) The major loss in pipe is \_\_\_\_\_  
a) frictional loss                      b) loss at entry                      c) loss at exit  
d) loss due to pipe fittings
- 9) The wetted perimeter of a circular pipe of diameter “d” is \_\_\_\_\_  
a)  $\pi d$                       b)  $1.5 d$                       c)  $d$                       d)  $d/4$
- 10) The hydraulic mean depth is the ratio of \_\_\_\_\_  
a)  $\frac{\text{Discharge}}{\text{Velocity}}$                       b)  $\frac{\text{Volume}}{\text{Cross Sectional Area}}$   
c)  $\frac{\text{Wetted Perimeter}}{\text{Cross Sectional Area}}$                       d)  $\frac{\text{Cross Sectional Area}}{\text{Wetted perimeter}}$
- 11) The rotating part in a centrifugal pump having vanes is \_\_\_\_\_  
a) casing                      b) impeller                      c) foot valve                      d) suction pipe

**Answer in one or two words**

**(1 mark each)**

- 1) List the various properties of fluids.
- 2) How is the ratio between weight of the volume of fluid is called?
- 3) What is the reason for the rise of water level in a small tube when immersed in it
- 4) In a flow through orifice what is the name of the section at which the diameter of jet contracts to a minimum diameter?
- 5) If Reynolds number is less than 2000, what is the type of flow?
- 6) What is the name of the velocity at which the flow changes from laminar to transition state?
- 7) State any two reasons for the occurrence of minor losses in a pipe?
- 8) What is the value of acceleration due to gravity?
- 9) What is the formula used to find the wetted perimeter of a rectangular channel?
- 10) What is the name of the hydraulic machine which transfers the energy from the impeller to the fluid?
- 11) In which type of reciprocating pump, the flow is discontinuous?
- 12) What operation is carried out in a centrifugal pump when water is not present in the suction pipe?
- 13) In which type of pump air vessel is used?

### **Part B**

**Answer in one (or) two sentences**

**(4 marks each)**

- 1) Define
  - a) Density
  - b) Relative density
- 2) Define
  - a) Surface tension
  - b) Specific weight
- 3) Define
  - a) Viscosity
  - b) Capillarity
- 4) Define
  - a) Pressure
  - b) Pressure head
- 5) Define
  - a) Centre of pressure
  - b) Depth of center of pressure

- 6) What is meant by major loss?
- 7) What are various minor losses? Show them with a neat sketch.
- 8) Write down the formula for finding the head loss using Darcy weisbach formula and explain the notations.
- 9) Write short notes on :
  - a) Wetted perimeter of a pipe.
  - b) Hydraulic mean depth of a pipe.
- 10) Write down the formula for finding velocity using Chezy's formula and also explain the notations.
- 11) Write short notes on :
  - a) Wetted perimeter of a channel.
  - b) hydraulic mean depth of a channel.
- 12) What is meant by most economical section of a channel?
- 13) How are pumps classified?
- 14) Compare single acting and double acting reciprocating pumps.
- 15) What is meant by priming in a centrifugal pump?
- 16) What are the uses of air vessels?

### **Part C**

**Answer shortly**

**(10 marks each)**

- 1) Draw the three types of immersed plane surfaces and give the expressions for total pressure and depth of centre of pressure for each type.
- 2) What is meant by orifice and explain with a neat sketch how theoretical velocity is determined for flow through an orifice ?
- 3) What are the three hydraulic coefficients? Explain.
- 4) What are the types of flow through pipes? Explain.
- 5) What is meant by critical velocity? How are they classified? Explain.
- 6) Explain with neat sketch: a) Hydraulic gradient line b) Total Energy line.
- 7) Draw a neat sketch and explain the function of a single acting-reciprocating pump.
- 8) Draw a neat sketch and explain the components and function of double acting reciprocating pump.
- 9) Explain with neat sketches of the working principle of centrifugal pump.
- 10) What are the uses of an air vessel? Explain its working principle.
- 11) Compare between centrifugal pump and reciprocating pump.
- 12) Write about vena contracta with a neat sketch.

## Part-D

### Answer in Detail

(20 marks each)

- 1) Determine the total pressure and depth of centre of pressure when a circular plate of diameter 2 m is immersed vertically in water.
  - a) When the top level of the plate coincides with the free water surface.
  - b) When the top level of the plate is 0.5 m below the water level.
- 2) Determine the total pressure and depth of centre of pressure when a square plate of size 3m is immersed vertically in water.
  - a) When top of the plate coincides with water level.
  - b) When top level of the plate is 2.5 m below the water level.
- 3) Determine the total pressure and depth of centre of pressure when a rectangular plate of size 1m wide and 2m height is immersed vertically in water.
  - a) When the top level of the plate coincides with water level.
  - b) When the top level of the plate is 1m below the water level.
- 4) In a pipe of diameter 100 mm and length 120 m, water is flowing at a velocity of 3m/s. Determine the loss of head. Assume Darcy's friction coefficient as 0.02.
- 5) Water flows through a pipe of diameter 150 mm and having length 400m. It discharges the water of 35.4 litres per second. Find the head loss due to friction. Take Darcy's frictional coefficient is 0.04.
- 6) A pipe of diameter 200 mm and 400 m length is connecting the two tanks having pressure difference 2m. Determine the quantity of water flow through the pipe. Assume coefficient of friction as 0.03.
- 7) A pipe of diameter 50 mm and 20 m length is connecting the two tanks having head difference 4m. Determine the velocity of flow through pipe. Take Chezy's constant  $C=60$ .
- 8) In a pipe of diameter 60 mm and length 30 m, water is flowing at a velocity of 3m/s. Determine the head loss due to friction. Take Chezy's constant  $C=60$ .
- 9) Find the quantity of water discharge through a rectangular channel 8 m wide for uniform flow at a depth of 3 m. The channel is having bed slope as 1 in 1000. Assume Chezy's constant  $C=55$ .
- 10) A channel of trapezoidal section has bed width 3m and bed slope is 1/1600. If the depth of flow is 2m and side slope of the channel is 1:1. Determine the discharge carried by the channel. Assume Chezy's constant  $C=50$ .
- 11) Find the rate of flow through a rectangular channel 6m wide for uniform flow at a depth of 4m. The channel is having bed slope as 1 in 1000. Assume Chezy's constant  $C=50$ .
- 12) A channel of trapezoidal section has bed width 8m and bed slope is 1/2000. If the depth of flow is 2m and side slope of the channel is 1:1, determine the discharge carried by the channel. Assume Chezy's constant  $C=40$ .

**Answers :** 1)b 2)a 3)a 4)d 5)b 6)a 7)c 8)a 9)a 10)d 11)b

# **UNIT - VIII**

## **HIGHWAY ENGINEERING**

### **8.1 INTRODUCTION**

Transport has a very important role to play in general development of the country and specially in its economic development. Transportation contributes to the economic, industrial, social and cultural development of any country.

#### **8.1.1 DEFINITION**

Highway engineering deals with the design, location, methods of construction and maintenance of all types of roads in plain country as well as in hilly areas.

#### **8.1.2 CHARACTERISTICS OF ROAD TRANSPORT**

- 1) Roads can be used by all types of vehicles. like cars, buses, trucks, two and three wheeled automobiles & animal driven carts.
- 2) It requires small investment and maintenance cost as compared to railways, airports, docks and harbours.
- 3) It offers flexibility of changes in direction of travel as per need, comfort and convenience.
- 4) In particular for short distance travel, road transport saves time. Because the road vehicles can be taken upto or very near to the part of destination.
- 5) It is nearest mode of transport for public.

#### **8.1.3 USES OF ROADS**

- 1) A good network of roads helps in the defence of a country during war and peace time.
- 2) Better law and order can be maintained.
- 3) Roads help in the growth of trade and other economic activities
- 4) Roads serving as feeder lines help the development of other means of communication.
- 5) Natural resources of an area can easily be tapped and improved.
- 6) Roads help to increase the land value enroute.
- 7) Roads aid good medical facilities to reach everyone.
- 8) They provide good commercial links between cities.
- 9) They facilitate communication on land
- 10) The improvement of highway system increases the mail facilities.

#### **8.1.4 HISTORY AND DEVELOPMENT OF ROADS IN INDIA**

The excavations of Mohanjo-daro and Harappa have revealed the existence of roads in India even 3500 years B.C. King Bithusara constructed pucca roads in Rajgir in Patna about 270 BC. Kautilya the first prime minister of emperor Chandra Gupta Maurya, has wrote a book known as Artha Shastra. He has mentioned the specifications for road widths, road surfaces, traffic control, etc. King Ashoka constructed a good network of roads during 270 B.C. During his period trees were planted on either side of the roads for giving shade to the travellers. Rest houses were provided at a distance of about 5 km to 7 km along the road for the comfort and convenience of the tired travellers.



During the Mughal period, the roads of India were greatly improved. 24 long roads connecting distant towns and cities were constructed during the mughal period. Sher Shah suri constructed the longest highway from Calcutta to Lahore, presently it is known as GT road NH1.

In 1855 AD during the regime of Lord Dalhousie, central and state public works departments (PWD) were formed.

Jayakar committee was formed in 1927 to investigate and report about the existing roads and the road development in the country. A central road organization was set up in 1930 and in 1935 a transport advisory committee was formed.

### **Golden Quadrilateral**

The “Golden Quadrilateral” is a highway network in India connecting Delhi, Mumbai, Kolkata and Chennai. It is the largest highway project in India consisting of four/six lane express highways at a cost of Rs.60,000crores. As of 2008, Golden quadrilateral carried about 40% of the country's traffic.

The Golden quadrilateral project establishes better and faster transport between many major cities and ports. It also accounts for smoother movement of products and people within India. It enables industrial and job development in smaller towns through access to markets. It provides opportunities for farmers through better transportation of their agricultural products to major cities and ports for export. It has enormously increased the economic growth of the country.

### **8.1.5 NAGPUR PLAN**

After the second world war, our country realized the deficiency of roads. A conference of the chief engineers of all the states and provinces was convened in 1943 by the central government at Nagpur. This was the first attempt to prepare a co-ordinate road development programme in a planned manner. This conference prepared the first 20year road development plan. It is popularly known as Nagpur plan.

#### **The following conclusions were drawn in Nagpur plan :**

- 1) To recommend an all Indian basis for geometric standards, highways and bridge specifications, road machinery and road organisations.
- 2) To classify all roads as National highways, State highways, District roads and Village roads.
- 3) To implement a balanced development of all classes of roads.
- 4) The central government to take up the complete financial responsibility of all the major roads.
- 5) The state government to take up the complete financial responsibility of all the other roads.

### **8.1.6 CLASSIFICATION OF ROADS**

#### **8.1.6.1 CLASSIFICATION OF ROADS ACCORDING TO LOCATION AND FUNCTION**

- |                           |                          |
|---------------------------|--------------------------|
| i) National Highways      | ii) State Highways       |
| iii) Major district roads | iv) Other district roads |
| v) Village roads          |                          |

### **i. National Highways (NH)**

These are major roads connecting major ports, foreign highways, capitals of states etc. National highways should have at least two lanes and be structurally strong and have best surface. The central government providing financial assistance for the construction of roads and maintenance is done by state governments.

### **ii. State Highways (SH)**

These are major roads within a state connecting district head quarters and important cities between themselves. Also it connects points in the national highways and other state highways. They should be preferably of two lanes.

### **iii. Major District Roads (MDR)**

District roads are constructed and maintained by corporation or municipality. These are the roads between district headquarters, commercial centres and other important places within the district. They establish connection with National, State highways and rail terminals.

### **iv. Other District roads (ODR)**

These roads connect important rural areas of production and market places with major district roads and state highways. These roads should have at least metalled surfaces and should be motorable throughout the years.

### **v. Village roads (VR)**

These roads connect villages with one another and with nearby cities. They may be metalled or stabilised earth roads. These are constructed and maintained by respective union offices.

## **8.1.6.2 CLASSIFICATION BASED ON THE MATERIAL USED FOR ROAD CONSTRUCTION**

- |                             |                          |
|-----------------------------|--------------------------|
| 1) Earth roads              | 2) Gravel road           |
| 3) Water Bound Macadam road | 4) Bituminous road       |
| 5) Asphalt road             | 6) Cement concrete road. |

## **8.2 HIGHWAY GEOMETRIC DESIGN**

The geometric design of a highway deals with the dimensions and layout of visible features of the highway such as alignment, cross section elements, sight distances and intersections.

The geometrics of highway should be designed to provide optimum efficiency in traffic operations with maximum safety at reasonable cost.

### 8.2.1 ROAD STRUCTURE (Fig 8.1)

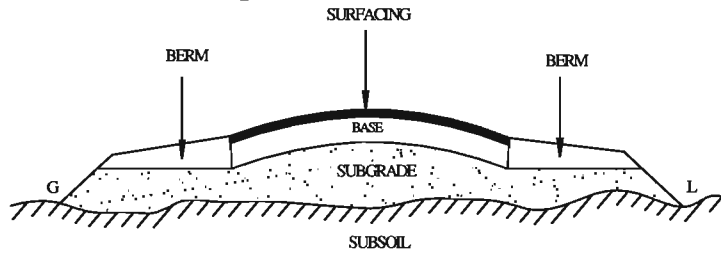

Fig. 8.1 ROAD STRUCTURE

1. **Subgrade** : It is the natural foundation on which the entire road structure rests. The life of road depends primarily on stable and dry subgrade.
2. **Formation** : It is the top surface of the subgrade.
3. **Sub-base**: It is the course laid between the base course and subgrade. It is used only when the bearing capacity of subgrade is poor or when the subgrade has poor drainage properties.
4. **Base course** : It is the structural foundation of the road. It is also termed as soling. The function of a road base is to transmit load of traffic from the surfacing to the subgrade. It should possess structural stability and should be of sufficient thickness to develop a good bond with the surfacing.
5. **Wearing course** : The topmost layer on which the traffic directly travels is known as wearing course. The road surfacing will provide a smooth and stable running surface. The surfacing should be impervious and should protect the base and the subgrade from the action of weather and rain water.

### 8.2.2 CAMBER OR CROSS SLOPE OR CROSS FALL (Fig 8.2)

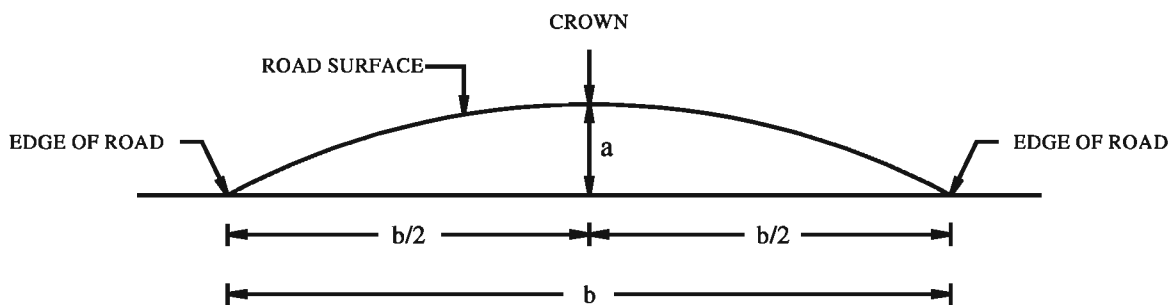

Fig. 8.2 CAMBER OR CROSS-FALL OF ROAD SURFACE

$$\text{Camber} = \frac{a}{b/2} = \frac{2a}{b}$$

The cross-section of a road surface shows the convexity upwards and the highest point on the curved surface is known as crown. Camber is defined as the slope of the line joining the crown and the edge of the road surface (Fig 8.2).

### 8.2.2.1 IRC RECOMMENDATIONS FOR ROAD CAMBER

Sl.No	Types of surface	Areas with greater than 100cm annual rainfall	Areas with less than 100cm annual rainfall
1	Earth, gravel, stabilised soil	1 in 16	1 in 24
2	Water bound macadam	1 in 36	1 in 48
3	Bituminous surfacings	1 in 60	1 in 60
4	Cement concrete roads	1 in 72	1 in 72

### 8.2.2.2 USES OF CAMBER

- 1) Provide surface drainage of rainwater.
- 2) Prevents the entry of water or moisture into the subgrade soil there by increasing the durability of the road.
- 3) Easy separation of up and down traffic.

### 8.2.2.3 TYPES OF CAMBER

- 1) **Sloped camber** i) Straight camber ii) Multiple camber
- 2) **Curved camber** i) Barrel camber ii) Parabolic camber iii) Elliptical camber
- 3) **Composite camber**

### 8.2.3 SUPER ELEVATION

On curves, there is a tendency for the vehicles to fall away from the outer portion of the curve due to the existence of centrifugal force. To overcome this effect, the outer edge of road is raised with respect to the inner edge. It is called as super elevation (Fig 8.3).

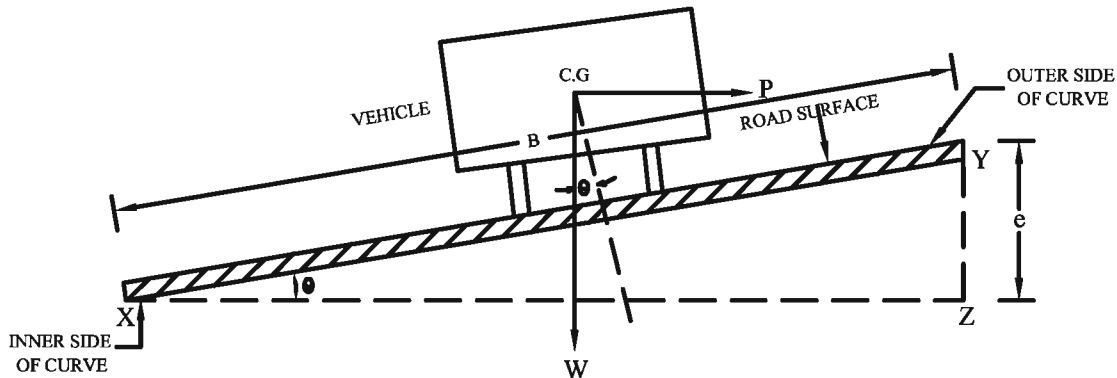

Fig. 8.3 SUPER ELEVATION

The amount of super elevation (e) can be calculated using the expression.

Where,

$$e = \frac{V^2}{126R}$$

V = Speed of vehicle in km/hr

R = Radius of curve in metre.

### 8.2.3.1 ADVANTAGES OF SUPER ELEVATION

- i) It increases the stability of fast moving vehicles on horizontal curves.
- ii) It counteracts the effect of centrifugal force.
- iii) On super elevated curves, the vehicles need not be slowed down.
- iv) The water can be drain off easily, therefore there is no possibility of formation of pot holes on the outer edge.
- v) It minimises the danger of skidding or toppling of fast moving vehicles.

### 8.2.4 ROAD GRADIENT

It is the rate of rise or fall of the road along its alignment. It is expressed as the ratio of difference in height of its extremes to the horizontal length between in them.

#### 8.2.4.1 Factors affecting gradient

- i) Topography of the country
- ii) Characteristics of the traffic
- iii) Rainfall in the locality
- iv) Drainage
- v) Safety

#### 8.2.4.2 Types of gradient

- i) Maximum gradient
- ii) Minimum gradient
- iii) Average gradient
- iv) Ruling gradient
- v) Exceptional gradient
- vi) Floating gradient

### 8.2.5 SIGHT DISTANCE

It is the distance along the centre line of the road over which a driver can see the opposite Vehicle on the road surface in order to avoid accident.

This distance should be such that the drivers and pedestrians are given sufficient time to react and not only avoid accident also to extent mutual road courtesy (Fig 8.4).

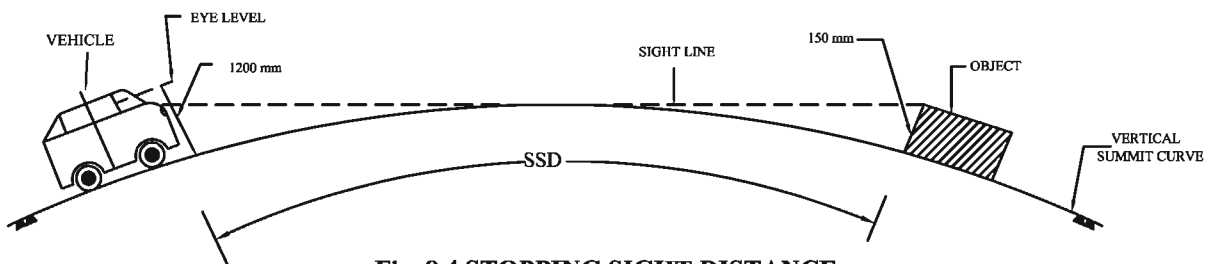

Fig. 8.4 STOPPING SIGHT DISTANCE

#### 8.2.5.1 TYPES OF SIGHT DISTANCE

- i) Crossing sight distance
- ii) Non-passing sight distance
- iii) Passing sight distance
- iv) Lateral sight distance

## 8.3 MATERIALS FOR HIGHWAY CONSTRUCTION

The materials required for the construction of highways can be broadly divided into the following two categories.

- 1) Aggregates
- 2) Binding materials. Example : Bituminous materials, cement.

### 8.3.1 TYPES OF ROAD AGGREGATES

The road aggregates can be classified in the following categories.

- i) Crushed rock aggregates
- ii) Gravels
- iii) Sand
- iv) Blast furnace slag

### 8.3.2 REQUIREMENTS OF GOOD AGGREGATE

Following are the desirable properties or requirements of a good road aggregate.

- i) Strength
- ii) Hardness
- iii) Toughness
- iv) Durability
- v) Shape
- vi) Adhesion with bitumen

### 8.3.3 TESTS FOR AGGREGATES

The following tests are carried out on the samples of road aggregates to ascertain its properties.

- 1) Water absorption test
- 2) Aggregate Crushing test
- 3) Aggregate Impact test
- 4) Attrition test

#### 1. Water absorption test

Three or four cubical stones of approximately 2.5 cm to 3 cm are dried in an oven for 72 hours. Its weight is recorded. Let it be  $W_1$ . Then the stones samples are immersed in water for 3 days. The water should be free from salt and impurities. After the immersion period, the stones samples are taken out and wiped by cloth. Its weight is taken. Let it be  $W_2$ . The water absorption is determined by using the following formula.

$$\text{Water absorption} = \frac{W_2 - W_1}{W_1} \times 100\%$$

For good aggregates, the water absorption should not exceed 0.6% of its dry weight.

## 2. Aggregate Crushing test:

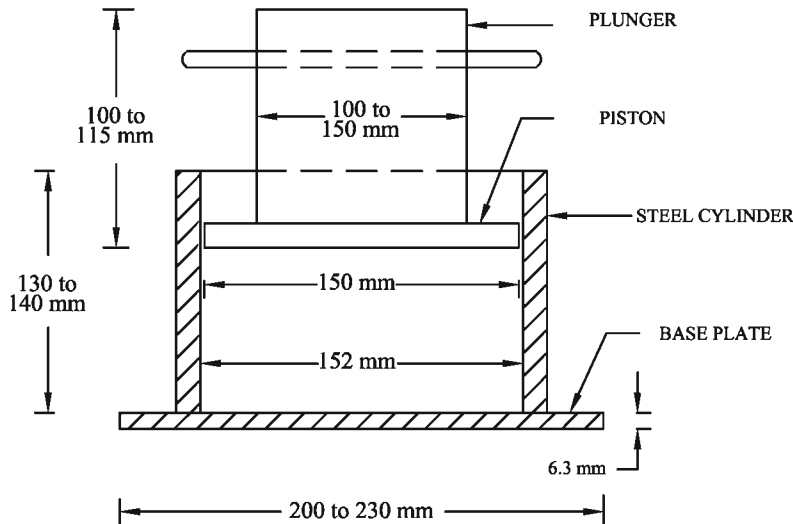

**Fig. 8.5 AGGREGATE CRUSHING TEST APPARATUS**

The sample of material taken for this test should pass through 12.5mm sieve and retained on 10mm I.S sieve. The material is heated to 1000-1100°C then it is cooled and it is weighed. let it be  $W_1$ . The material is placed in a cylinder in three equal layers, each layer being tamped 25 times by using a tamping rod. The plunger is placed on the upper surface and a load of 40 tonnes is applied at the uniform rate of 4 tonnes per minute by the compression machine. The crushed aggregate is removed and sieved on 2.36 mm IS Sieve. The material passing through this sieve is collected and weighed as  $W_2$ . The aggregate crushing value is obtained by the following expression (Fig 8.5).

$$\text{Aggregate crushing value} = \frac{W_2}{W_1} \times 100$$

## 3. Aggregate Impact test

The test is carried out on stone aggregates in a machine known as impact testing machine (Fig 8.6). It consists of a metal circular base firmly fixed on the floor. A cylindrical steel cup which is detachable is rigidly fastened to the base plate. The internal diameter and depth of cup are 10.2 cm and 5 cm, respectively. A metal hammer of weight about 13.5 to 14 kg, is free to move between the vertical guides. A key is also provided to support the hammer while fastening or removing the cup.

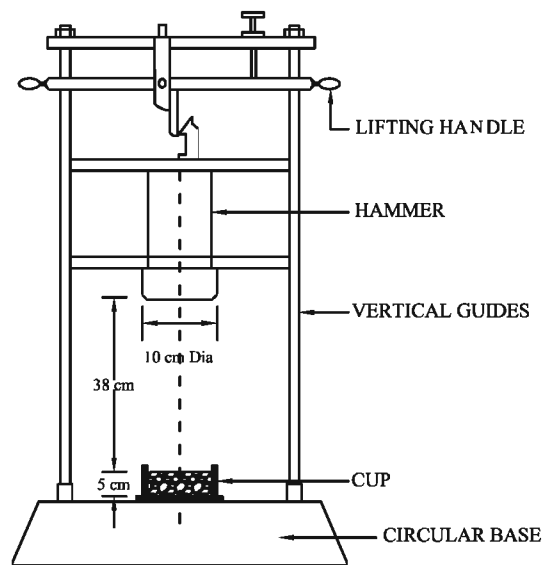

**Fig. 8.6 IMPACT TESTING MACHINE**

### The test procedure is given below

- 1) The sample is broken into chips passing through 12.5 mm I.S. sieve and retained on 10 mm I.S. sieve. The material is heated in an oven at a temperature of 1000°C to 1100°C for 4 hours and then cooled.
- 2) The sample is placed in the cup and the hammer is allowed to fall from a height of 38 cm for a total of 15 blows. It should be seen that each blow is delivered at an interval of not less than one second.
- 3) The crushed aggregate is then removed from the cup and it is sieved on 2.36 mm I.S. sieve. The material passing through the sieve is collected and weighed. The aggregate impact value is obtained by the following expression.

$$\text{Aggregate impact value} = \frac{W_2}{W_1} \times 100$$

Where  $W_1$  = Original weight of oven dry sample

$W_2$  = Weight of material passing 2.36 mm I.S. sieve.

### 4. Attrition test

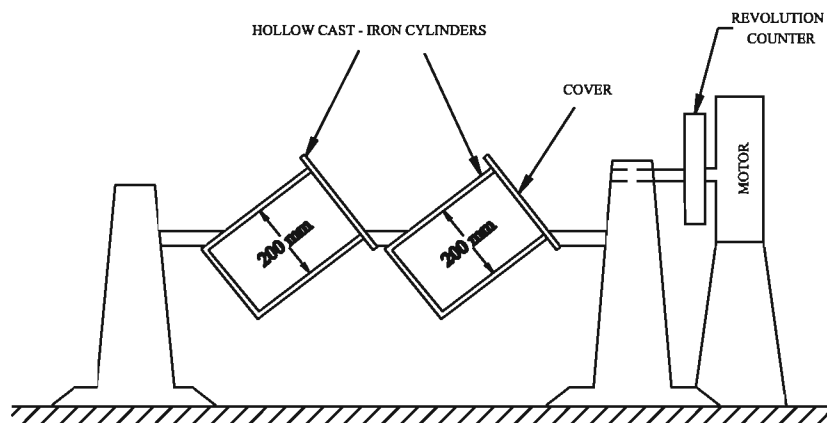

Fig. 8.7 DEVAL ATTRITION TESTING MACHINE

The test is conducted by using Deval attrition testing machine (Fig 8.7). It consists of two cast iron cylinders of inside diameter 200mm and length 300mm mounted on a shaft which makes an angle of 30° with the axis of rotation. Dry aggregate specimen of 5kg ( $W_1$ ) is placed in each cylinder. 6 numbers of steel spheres of 48mm diameter with weight of each being 390gm to 445gm is placed in each cylinder. The cylinders are rotated for 10,000 revolutions at an average speed of 30 to 33rpm. The material removed from the cylinder is sieved on 1.7mm IS sieve. The material retained on IS sieve is dried and weighed ( $W_2$ ).

The percentage of wear is worked out by the following expression

$$\text{Percentage wear} = \left[ \frac{W_1 - W_2}{W_1} \times 100 \right]$$

where,

$W_1$  = Original weight of sample

$W_2$  = Weight of material retained in IS 1.7 mm sieve.



### 8.3.4 TESTS FOR BITUMINOUS MATERIAL

Following are the tests for bituminous material

- 1) Ductility test
- 2) Loss on heat test
- 3) Float test
- 4) Penetration test
- 5) Softening point test
- 6) Solubility test
- 7) Specific gravity test

The first two tests that are commonly performed are discussed in detail.

#### 1. Ductility test:

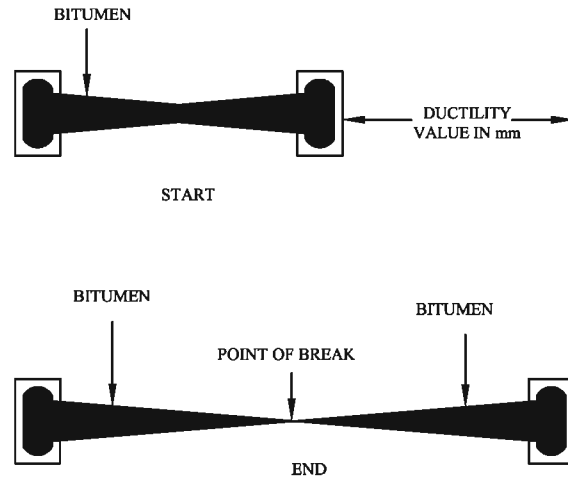

**Fig. 8.8 DUCTILITY TEST**

The sample is cast in standard briquette mould whose cross-section at the minimum width is 10mm x 10mm. The standard briquette of bitumen is stretched upto the thread breaks. The increase in length is measured in centimeter, it is called ductility value. The test is conducted at a temperature of  $27^{\circ}\text{C} \pm 0.5^{\circ}\text{C}$  at a rate of pull of  $50\text{mm} \pm 2.5\text{mm}$  per minute (Fig 8.8).

For satisfactory performance, the ductility value of bitumen should not be less than 50.

#### 2. Loss on heat test

- i) About 50 gm of sample is taken and it is weighed ( $W_1$ ).
- ii) It is heated for 5 hours at a temperature of  $163^{\circ}\text{C}$  in a special oven.
- iii) The specimen is taken out and it is weighed again ( $W_2$ ).
- iv) The loss in weight due to heating is expressed as a percentage by weight of original sample.

$$\text{Loss in weight on heating} = \frac{W_1 - W_2}{W_1} \times 100$$

For the bitumen used in pavement mix loss in weight on heat should not be greater than 1%.

## 8.4 STABILISATION AND CONSTRUCTION OF ROADS

Stabilisation is the process on soil to improve its strength or bearing power by reducing its susceptibility to the adverse influences of water and traffic.

### 8.4.1 OBJECTS OF SOIL STABILIZATION

- 1) To increase shear strength of soil
- 2) To increase resistance to softening action of water
- 3) To increase the flexibility without deformation and cracking under traffic.
- 4) To avoid changes in soil characteristics due to increase or decrease of water content.
- 5) To alter the chemical properties of soil to suit the traffic requirements.
- 6) To reduce shrinkage and swelling due to water content.
- 7) To increase the compressive strength of soil irrespective of moisture content.

### 8.4.2 METHODS OF SOIL STABILIZATION

Following are the various methods of soil stabilization.

- 1) Bituminous stabilization
- 2) Cement stabilization
- 3) Chemical stabilization
- 4) Complex stabilization
- 5) Electrical stabilization
- 6) Grouting stabilization
- 7) Lime stabilization
- 8) Mechanical stabilization
- 9) Thermal stabilization

### 8.4.3 EARTH ROADS

It is the cheapest type of road in construction because it is made from the natural soil available at the site. It provides a link for very light traffic.

#### 8.4.3.1 CONSTRUCTION OF EARTH ROAD:

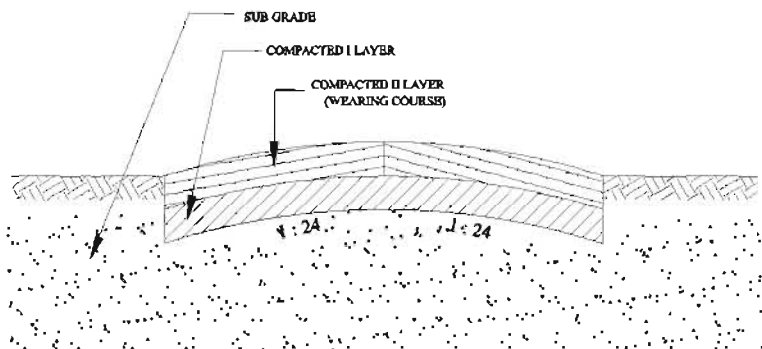

Fig. 8.9 CROSS SECTION OF EARTH ROAD

- 1) The centre line is fixed and reference pegs are driven for the guidance of vertical profile of road.
- 2) The ground is cleared by removing all vegetation.
- 3) The subgrade is prepared and it is provided with necessary camber (1 in 24) and longitudinal gradient.
- 4) The subgrade is properly compacted by rolling.
- 5) A layer of 10 cm graded soil is spread evenly and rolled at optimum moisture content with sheep foot rollers.
- 6) If required, another soil layer of 10 cm thick is also spread and rolled properly to act as wearing course.
- 7) The surface is water cured for 4 or 5 days without traffic.
- 8) The compacted earth road is allowed to dry for a period of about 5 to 10 days before opening it for traffic (Fig 8.9).

#### 8.4.3.2 MAINTENANCE OF EARTH ROAD

Proper and constant maintenance is required to keep the road in service. Hence, periodic repairs to pot holes and ruts are essential. The pot holes and ruts are filled with earth and compacted by hand rammers. Side drains are also properly maintained as the life and efficiency of the earth roads mainly depend on the efficient drainage system.

#### 8.4.4 GRAVEL ROADS

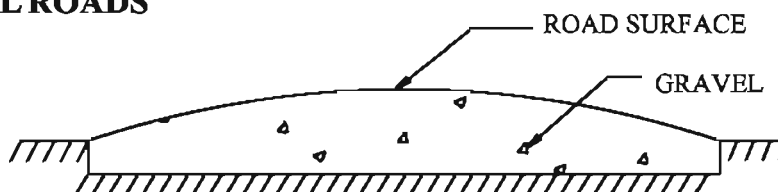

FIG.8.10 TRENCH TYPE CONSTRUCTION OF GRAVEL ROAD

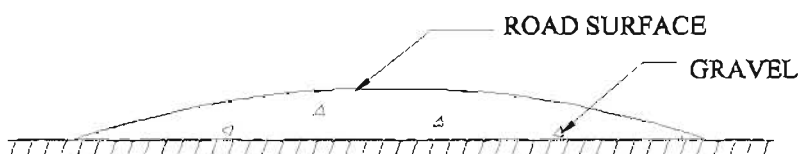

Fig. 8.11 FEATHER EDGE TYPE CONSTRUCTION OF GRAVEL ROAD

Gravel roads are considered superior to earth roads as they can carry heavier traffic. These roads are constructed with well graded quality gravel obtainable from river beds or by crushing the stones.

#### 8.4.4.1 METHODS OF CONSTRUCTION OF GRAVEL ROAD

- 1) Trench Spread method (Fig 8.10)
- 2) Feather edge spread method (Fig 8.11)

In the trench type construction subgrade is prepared by excavating a shallow depth. In the feather type construction gravel is spread on the existing base without cutting a trench.

#### 8.4.4.2 CONSTRUCTION OF GRAVEL ROAD

- 1) The subgrade is prepared to proper gradient, camber and compacted well.
- 2) On the prepared subgrade, a mixture of gravel, earth and sand are spread to the required thickness.
- 3) The compacted depth of gravel road is generally 200 mm. It is obtained in two layers, each of compacted thickness of about 100 mm.
- 4) The layer is rolled by using smooth wheeled light rollers starting from the edges and proceeding towards the centre.
- 5) During rolling, proper gradient and camber are maintained and sufficient care is taken to see that no pebbles get crushed under the roller.
- 6) The camber is checked at regular intervals and it is corrected if necessary.
- 7) A thin layer of sand of about 5 mm to 10 mm thickness is provided before opening the road to traffic.

#### 8.4.5 CONSTRUCTION OF WATER BOUND MACADAM ROAD (W.B.M. ROAD)

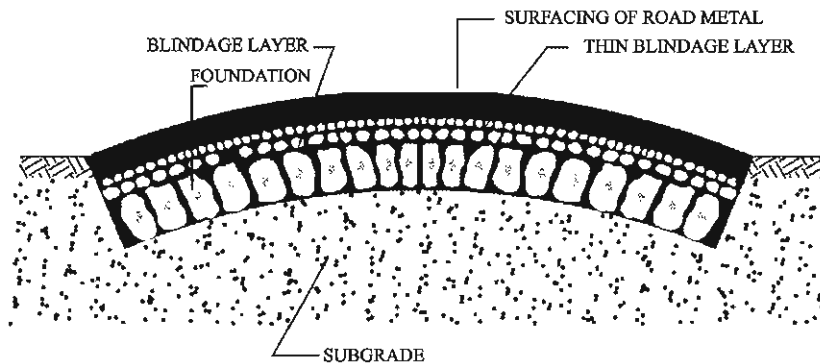

Fig. 8.12 CONSTRUCTION OF WATERBOUND MACADAM ROAD

The W.B.M. road (Fig 8.12) is constructed in the following stages

- 1) Subgrade
- 2) Sub-base
- 3) Base
- 4) Wearing course
- 5) Providing berms
- 6) Opening for traffic.

##### 1. Subgrade and kerbs

The subgrade is prepared to the required grade and camber. The depressions and pot holes on the existing road surfaces are filled up and the corrugations are removed by scarifying. Good earth is used in the construction of shoulder.

##### 2. Sub-base

It is provided only if necessary. It is prepared with locally available granular materials. The sub-base material is spread over the whole width of formation and rolled to the shape of the camber.

### 3. Base or foundation course

12 to 18mm size boulders or broken stones hand packed, with little voids as possible is spread and the surface is rolled with a 10 ton roller. The rolling should be started from edge of road to the centre. Each successive strip must overlap the preceding strip to avoid formation of weak points.

### 4. Wearing course

This can be laid in one or two layers, each layer not exceeding 15 cm thick, depending upon the total thickness required.

- a. **Spreading of metal** : Initially stone metal is spread over the prepared surface to the required thickness. After spreading, the metal is hand packed properly to the required gradient and camber.
  - b. **Rolling dry** : The layer of stone metal is then rolled by 8 ton roller, starting from the edges first and gradually shifting towards the centre. The dry rolling provides interlocking of aggregates.
  - c. **Screeding and wet rolling** : The screeding should be spread uniformly. The road surface is sprinkled with plenty of water on it and rolled. Hand brooms are used to sweep the wet screenings into the voids. Additional screedings are applied and rolled till the coarse aggregates are well bonded and firmly set.
  - d. **Topping, watering and rolling** : The next day, a final coating of sandy soil containing clay and moorum and 75% sand is spread to a thickness of 5mm. The surface is made wet by adding large quantity of water so that the materials reach the intersections of stones. The surface is then rolled with water sprinkling on the roller wheels to prevent the binding material from sticking to the roller surface.
  - e. **Curing** : The surface is kept wet for 7 to 9 days for curing.
5. **Providing berms** : Usually, earthen berms with outward slope are provided. By filling earth by the side of the kerbs the level is raised to the top of road surface.
6. **Opening for traffic** : After curing the road is opened for traffic.

#### 8.4.5.1 DEFECTS OF WBM ROAD

- i) Formation of pot-holes and ruts due to the loss of soil binder by rain water washing.
- ii) Disintegration of road materials caused by the large variation of temperature.
- iii) Damage caused by heavy traffic.
- iv) Excessive tensile stresses induced into the top layer of pavement due to wheel load.
- v) Loosening of surface metal by suction of binder caused by the fast moving pneumatic wheel tyres.
- vi) Crushing of road metal due to attrition and impact by steel-tyred wheels.
- vii) Blowing of the crushed and pulverised road metal by wind or by fast moving vehicles.

## 8.4.6 CONSTRUCTION OF BITUMINOUS ROADS (Fig 8.13)

There are number of techniques of constructing bituminous roads. Here we will discuss surface dressing with single coat.

### Surface dressing with single coat:

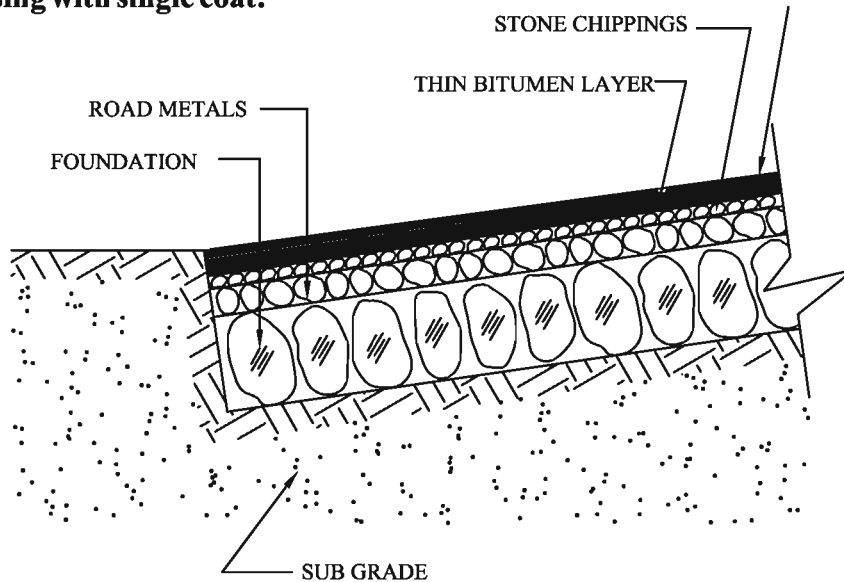

Fig. 8.13 BITUMEN SURFACE DRESSING (SINGLE COAT)

The construction procedure in surface dressing treatment of road surface with single coat is as follows:

#### 1. Preparation of road surface

The road surface is prepared to the required shape and camber removing all the depressions, pot holes, ruts or etc. It is made free of dust or loose materials. If the existing base course is of soil stabilized material or made of porous aggregates, a prime coat is applied.

#### 2. Application of bitumen

The bitumen is heated to the desired temperature and it is applied on the prepared road surface at the specified rate. The bitumen should be applied uniformly without formation of any pool on the surface.

#### 3. Spreading the stone chippings

The cover material in the form of stone chippings of specific qualities should be clean, hard, durable and cubical in shape. The chippings are spread on the surface immediately after the application of bitumen at the specified rate. The aggregates should be spread uniformly without accumulation of chippings at any particular spot.

#### 4. Rolling

The chippings are then rolled by a medium roller with the usual precautions and the rolling is continued until the chippings are thoroughly embedded in the bitumen. This can be observed when there is no movement of any metal when the roller is moving on the surface.

## 5. Finishing

The surface is then cleaned and it is checked for its cross profile. A tolerance of 2 mm in thickness per metre length is permitted. The road is then opened for traffic after 24 hours.

### 8.4.7 CONCRETE ROADS

Concrete road surfacings are superior than other kinds of road surfacings. The cement concrete road provides rigid surface.

#### 8.4.7.1 METHODS OF CONSTRUCTION OF CEMENT CONCRETE ROADS

- i. Alternative bay method
- ii. Continuous bay method

##### i. Alternative bay method :

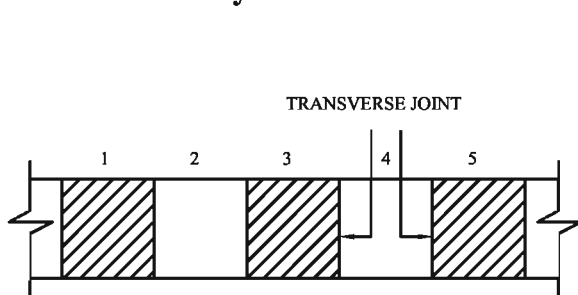

Fig. 8.14 SINGLE LANE ROAD

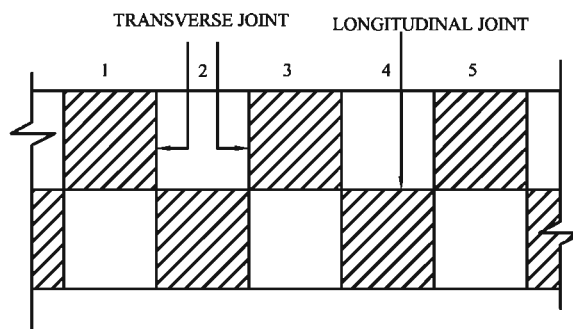

Fig. 8.15 DOUBLE LANE ROAD

In this method, if the road is of single lane, it is divided into suitable bays of 6m to 8m length and the construction work is carried out in alternate bays as shown in fig 8.14.

If the road is of double lane the construction work is carried out in odd bays in one lane and in even bays in the other lane as shown in fig 8.15.

The construction of other bays is commenced after the concrete laid in earlier bays dries out, i.e., nearly after one week or so.

##### ii. Continuous bay method :

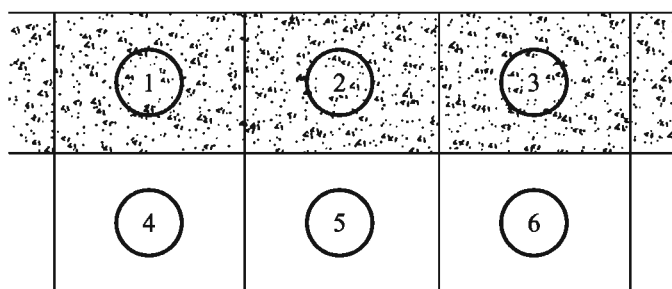

Fig. 8.16 CONTINUOUS CONSTRUCTION METHOD

In this method, all the bays 1, 2 and 3 are laid continuously without any break as shown in (Fig 8.16). Construction joints are provided at the end of the days work.

## **8.4.7.2 CONSTRUCTION PROCEDURE FOR CEMENT CONCRETE ROADS**

### **Stages of Construction**

- 1) Subgrade preparation
- 2) Base course preparation
- 3) Formwork
- 4) Watering the prepared base
- 5) Mixing, placing and spreading of concrete
- 6) Compaction and floating
- 7) Belting
- 8) Brooming
- 9) Checking the finished surface
- 10) Curing
- 11) Filling joints and edging.

#### **1. Subgrade Preparation**

The subgrade is properly compacted and is brought to the required gradient and camber. The surface is checked by means of a scratch template by placing it at right angles to the centre line of the road. The surface is brought to true profile.

#### **2. Base course preparation**

If found necessary, a base course or a foundation course is provided over the subgrade. It provides levelled, smooth and uniform support. The base course may be a water bound macadam or stabilized.

#### **3. Formwork**

After the base course is completed, formwork for the concrete slab is laid exact to grade, camber and alignment. The forms which are set on the edges may be of steel or timber. The depth of the formwork should be equal to the thickness of the slab and should be supported firmly throughout its length. Before setting, the form should be thoroughly cleaned. After setting, it should be oiled and checked for line and grade before concreting.

#### **4. Watering the prepared base**

The object of water is to saturate the subgrade or base so that it will not absorb any water from the concrete when it is laid over it. After the form work has been set, the surface of base or subgrade is wetted with as much water as it can readily absorb. Water should not be allowed to stand on the surface. The surface should be kept wet for about 12 hours before concreting.

#### **5. Mixing, placing and spreading of concrete**

The ingredients of concrete are mixed in proper proportion in concrete mixers adding exact quantity of water as per the designed water cement ratio. The concrete is placed in the form work to its full width in layers not exceeding 5 cm thick and proceeded lengthwise. The top most layer should be to the actual profile. Necessary transverse and longitudinal joints should be provided.

#### **6. Compaction and floating**

The compaction and consolidation of concrete may be done manually by means of hand tampers or by means of mechanical vibrators. The surface is tamped longitudinally. Then the surface is finished by hand floats to produce uniform and even surface without corrugations.



## **7. Belting:**

Belting is done to finish the surface. It is done with a canvas or rubber belt, 15 to 30 cm wide, fitted with handle at both the ends. It is applied cross-wise by two persons and moved longitudinally.

## **8. Brooming**

Brooming is resorted to when a rough and gritty surface is desired. The broom is lightly drawn across the centre line from edge to edge of the road surface. It is done immediately after belting and when concrete is partially set.

## **9. Checking the finished surface**

The road surface is now checked for the desired grade and camber and for evenness. The checking is done frequently with a 3 m long wooden straight edge during floating. If the tolerance is more than 2 mm per metre the portion of the road surface should be corrected.

## **10. Curing**

It is carried out for the concrete to harden. After about ½ to 2 hours of finishing the surface, the surface is moistened to prevent concrete from drying. On the next day, any regular curing system would be adopted.

**The curing system may be as follows.**

- a) Use of moist gunny bags
- b) Ponding
- c) Moist sand or earth covering
- d) Use of moist gunny bags for a day and followed by calcium chloride etc.,
- e) Steam curing, membrane covering, painting etc.

## **11. Filling joints and edging**

All the joints are to be filled properly with suitable material and finished to the profile of the surface.

After completion of concrete slab, before allowing traffic brick edging or W.B.M. pavement may be provided to protect the edge of the slab. In case of brick edging, earth is spread on the berms upto the top of brick edging.

### **8.4.7.3 MERITS OF CONCRETE ROADS**

The merits of concrete roads are listed below.

- 1) Low maintenance cost
- 2) Concrete roads are dustless, smooth and non-slippery.
- 3) Can be laid on any subgrade.
- 4) Can easily be reinforced when required.
- 5) Do not develop corrugations.

- 6) Last longer if laid properly.
- 7) Provide a smooth, safe and excellent surface under all conditions.
- 8) Have better weather resisting qualities.

#### **8.4.7.4 DEMERITS OF CONCRETE ROADS**

The demerits of concrete roads are listed below.

- 1) High initial construction cost.
- 2) Develop cracks due to temperature variation
- 3) Construction requires skilled workmanship & supervision.
- 4) Require time for curing.
- 5) Glare due to reflection of light may lead to accidents.
- 6) Cutting of the slab after laying for any purpose is difficult and costly.

### **8.5. ROAD SIGNALS**

#### **8.5.1 ROAD SIGNALS**

To control the movement of traffic, to regulate and to caution, the equipments that are operated in electricity emitting various colours of lights are called as Signal. The objectives for the installation of signals are as follows:

- i) To control and regulate the movement of traffic in a proper way
- ii) To control and reduce the speed of vehicles that move through major highways and other secondary highways.
- iii) To coordinate the movement of vehicles that move through or move towards a certain place and to proceed them with certain cautions.
- iv) To stop or halt the continuous movement of traffic for a short period of time in a particular road so as to enable pedestrians and other vehicles in the perpendicular roads to cross safely.
- v) To help and guide the vehicles to choose their respective roads or lanes.
- vi) To halt vehicles for a short period of time and to regulate them at major crossing and at places where disturbances are expected to occur for moving traffic.

#### **8.5.2 SITUATIONS FOR INSTALLATION OF SIGNALS**

- i) Various roads that intersect at a particular junction should have at least minimum number of vehicles and pedestrians utilizing them.
- ii) Heavy traffic zones in important roads where in signals need to be installed for easy negotiation.
- iii) Zones which have large number of intersections are prone for occurrence of accidents. Hence it becomes vital to install signals at the intersections.

- iv. Signals could also be installed on the following specific situations.
- a) School zones wherein the major number of pedestrians crossing will be infants and children.
  - b) Places where majority of the pedestrians are either blind, aged or physically challenged.  
Example:- Blind school
  - c) Places where the situation suddenly changes from a village to a city.
  - d) At the starting point where the roads attain steeper gradients.

### 8.5.3. TYPES OF SIGNALS

Signals can be classified as follows

- 1) Traffic control signals

This type may either be

- i) Fixed time signals (Fig 8.17)
  - ii) Traffic actuated signals
- 2) Pedestrian Signals
  - 3) Special Signals.

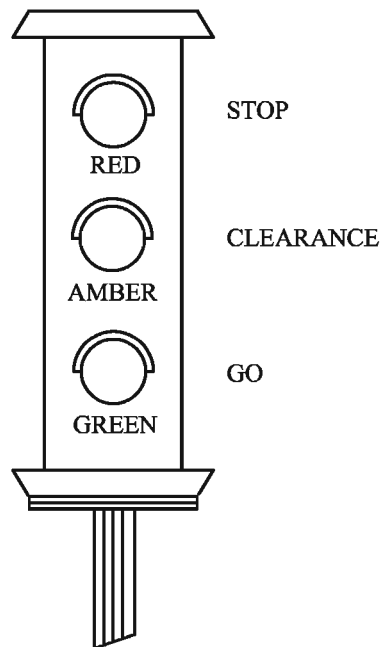

Fig. 8.17 FIXED TIME SIGNALS

## 8.6 ROAD SIGNS

The road sign or traffic sign is the most used and least costly of traffic control devices.

### 8.6.1 PURPOSE OF ROAD SIGNS

- i) To achieve regular, control and orderly movement of traffic.
- ii) To reduce the chances of accidents.
- iii) To cross the road by pedestrians at intersections.
- iv) To guide drivers about the road conditions ahead.
- v) To direct traffic on different routes.

### 8.6.2 TYPES OF ROAD SIGNS

The road signs are classified in the following three categories:

- 1) Regulatory or Mandatory signs
- 2) Warning or Cautionary signs
- 3) Guide or Informatory signs

#### 1. REGULATORY SIGNS OR MANDATORY SIGNS

These signs are used to inform the road users of certain laws, regulations and prohibitions. The violation of these signals is of legal offence (Fig 8.18).

Some of the regulatory signs are (Fig 8.19):

- i) Overtaking Prohibited, ii) No Parking, iii) Speed Limit, iv) Horn Prohibited,
- v) Restricted End Sign

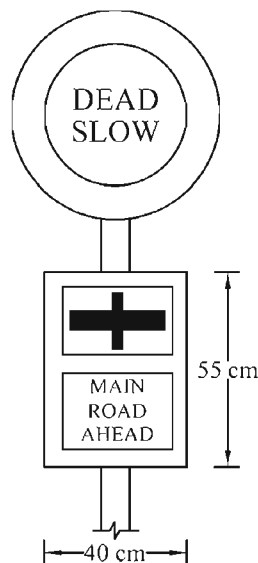

**Fig. 8.18 GENERAL SPECIFICATION OF REGULATORY SIGN**

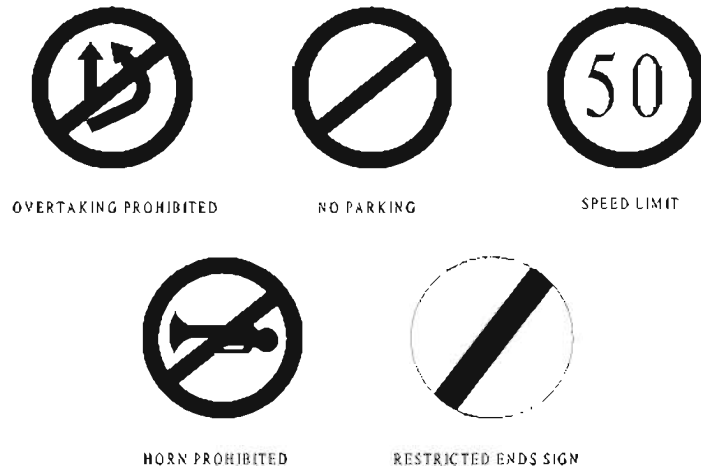

**Fig. 8.19 REGULATORY SIGN**

**2. WARNING SIGNS OR CAUTIONARY SIGNS (Fig 8.20)**

These signs are used to warn the road users of certain hazardous conditions that exist on or adjacent to the roadway. The warning signs are in the shape of equilateral triangle with its apex pointing upwards are provided adjacent to the road.

Some of the warning signs are (Fig 8.21) :

- i. Right hair pin bend    ii. Ferry    iii. Right side road    iv. Left side road, v. Narrow bridges
- vi. Right reverse bend    vii. Left hand curve    viii. School    ix. Hump or rough road    x. Right hand curve

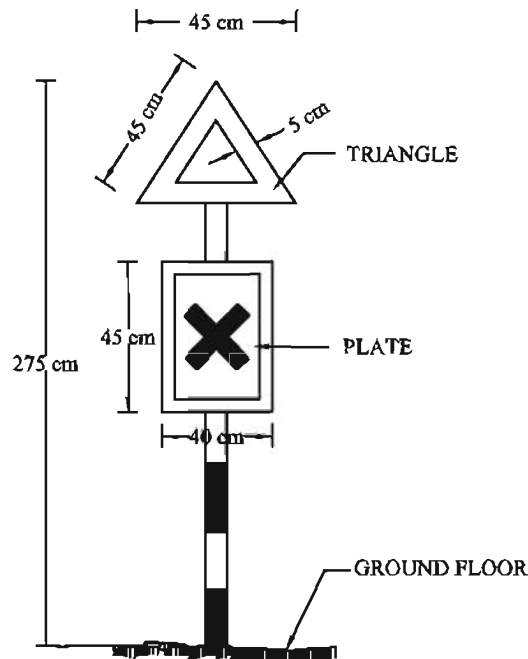

**Fig. 8.20 GENERAL SPECIFICATION OF WARNING SIGN**



Fig. 8.21 WARNING SIGNS

### 3. GUIDE OR INFORMATORY SIGNS

These signs are used to provide information and guidance for the road users. These signs also indicate the places and route identifications

Some of the informatory signs are (Fig 8.22):

- i. First aid post sign
- ii. Advance direction sign

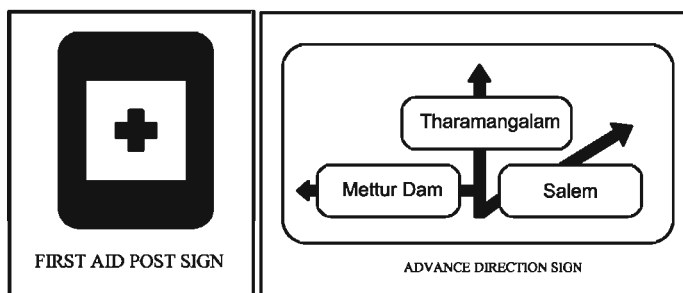

Fig. 8.22 INFORMATORY SIGNS

## 8.7 ROAD ACCIDENTS

Road accidents have increased in India during the last few years. To prevent accidents that occur in National Highways the vehicle drivers and pedestrians should always be alert and a feeling of unity should always prevail between them.

### Data regarding accidents and registration

Any accident that involves a motorized vehicle is classified as motor vehicle accident. There are many reasons for motor vehicle accidents. If the same situation prevails in a particular place as that of the previous one in which an accident has occurred, then there are plenty of chances for similar such accident to take place. Therefore if various informations regarding an accident in a particular place is collected, it will be helpful to avoid such accidents to occur in the same place. The speed of the vehicle, the route of the vehicle, the intensity of lighting at the accident zone, natural condition, road conditions, condition of driver, vehicle condition are the factors or details that are to be collected as information. Most important is that these information must be true and not biased.

To analyze the accidents elaborately, collision diagram and condition diagram are prepared. All accidents that are explained by means of schematic diagrams during the

investigation period are called as collision diagrams. The plan of a particular accident place is called as condition diagram. All details that are required for analysing an accident can be obtained from these two diagrams. Based on the information or details that are obtained from these diagrams, necessary preventive measures such as fixing caution sign boards, signals or construction of speed breakers could be adopted.

### **8.7.1 CAUSES OF ROAD ACCIDENTS**

Accidents may occur due to any one or more than one of the following reasons.

- 1) Driving the vehicle after consuming alcohol.
- 2) Driving the vehicle dangerously not caring about others on the road.
- 3) Driving the vehicle at very high speeds more than that specified.
- 4) Ignoring the sign boards and signals.
- 5) Carelessness on roads.
- 6) Standing in the middle of a road and watching something else other than traffic.
- 7) Crossing a road without noticing or keeping in mind the vehicles that pass through the road.
- 8) Children playing in roads.
- 9) Interceptions that disturb the movement of traffic for example grazing of cattle nearby a road which may lead to movement of cattle haphazardly across the road.
- 10) Parking the vehicles at wrong places.
- 11) Insufficient sight distances, narrow roads, dangerous curves and other defective geometric designs of roads.
- 12) Slow speed vehicles interrupting expressways.
- 13) Improper street lighting.
- 14) Fault mechanism in vehicle for example failure of brake mechanism due to defective parts.

### **8.7.2 EFFECTS OF ROAD ACCIDENTS**

World health organization in one of its reports published in the year 2009 has stated that the number of deaths in road accidents in India is greater than any other country in the world. As per the predictions of national crime records bureau, in India 13 persons die every hour due to road accidents. If 10 people die all over the world in road accidents there is one Indian in it.

All over the nation, every year around one and half lakhs people die in road accidents. Of this death toll 85 percent are male persons. They are mostly the head of their families taking care of it in their individual income. The family gets shattered followed by their sudden demise. The position of the family is totally turned upside down in a day due to such deaths. Reports say that the life of their children is totally changed to a different unexpected direction.

### **8.7.3 SAFETY MEASURES**

The main objective of the safety measures is to make the vehicles and pedestrians utilize the roads in a better way.

- 1) By constructing barricades or hand rails on either side of the road, the path of the heavy vehicles could be separated from the pedestrian's platform.
- 2) Construction of subways for the pedestrians to cross important congested roads.
- 3) Proper markings on roads could be made at the road intersections so as to enable and guide the pedestrians to cross the roads with ease.
- 4) Controlling the speed of the vehicles that enter the city by severe supervision

These are some of the safety measures that are adopted to prevent accidents.

## **8.8 ROAD SIDE DEVELOPMENTS**

It is the art or science of planting and growing of trees along the sides of the highway.

### **8.8.1 USES OF ROAD SIDE ARBORICULTURE**

- 1) To provide shade to the road users.
- 2) To provide fruit bearing trees and timber.
- 3) To stop soil erosion.
- 4) To provide very attractive landscape of road sides.
- 5) To purify the air.
- 6) To aid rainfall.
- 7) To absorb noise and intercept exhaust fumes from road vehicles.
- 8) To act as a crash barrier for vehicles out of control.

### **8.8.2 SELECTION OF TREES FOR ROAD SIDE ARBORICULTURE**

Trees are selected on the basis of the following considerations.

- 1) They should provide a large and dense crown.
- 2) They should be easy to establish, develop fast and be strong to resist heavy wind blows.
- 3) They should withstand lopping and pruning.
- 4) They should have long life.
- 5) They should yield atleast fruit or timber
- 6) They should not be clumsy and should grow centrally.
- 7) They should provide shade always.
- 8) They should resist diseases.



## QUESTIONS

### PART-A

Choose the correct Answer

(1 mark each)

- 1) Which department is formed by Lord Dalhousy?  
a) Central Public Works Department                      b) Indian Railway Department  
c) Air Transport Department                                  d) None of the above
- 2) When did our country realize the shortage of road?  
a) After First World war                                      b) After Second World war  
c) During war against china                                  d) During war against pakistan
- 3) The road connecting state capitals is called \_\_\_\_\_.  
a) National highway      b) State highway      c) District roads      d) Village roads
- 4) The camber for earthen road constructed at a locality having rainfall more than 100cm is  
a) 1 in 16                      b) 1 in 36                      c) 1 in 60                      d) 1 in 72
- 5) Mention the weight of roller used in water bound macadam road for compacting the foundation course.  
a) 7 tonnes                      b) 8 tonnes                      c) 9 tonnes                      d) 10 tonnes

Answer in one or two words

(1 mark each)

- 1) Which transport is suitable for short distance travel?
- 2) How many number of long roads were constructed during Mughal Period?
- 3) In which year Nagpur conference was held?
- 4) What is the name of the slope joining the edge and highest point of the road surface?
- 5) What is the camber to be provided for cement concrete road?
- 6) Which type of road has high initial cost?
- 7) Draw the sign to indicate "Over taking prohibited".
- 8) Draw the sign of "Informatory Sign Board".
- 9) Draw the sign to indicate "Narrow bridge"?
- 10) What are the two methods of construction of gravel roads?
- 11) What are the two methods of construction of concrete roads?

## **PART-B**

**Answer in one or two sentences**

**(4 marks each)**

- 1) What are the objectives of highway engineering?
- 2) Classify the roads according to administrator.
- 3) Classify the roads according to materials used.
- 4) What is meant by camber? What are its types?
- 5) What are the uses of camber?
- 6) What is meant by super elevation ?
- 7) What are the uses of super elevation?
- 8) What is meant by sight distance?
- 9) What are the types of sight distance?
- 10) Name some of the materials used as aggregates for road construction.
- 11) What are the requirements of good aggregates for construction of roads?
- 12) Name any four methods of soil stabilization?
- 13) Write any four disadvantages of WBM Road.
- 14) What are the points to be kept in mind while selecting trees for Arboriculture?
- 15) Draw any two cautionary signs. which are provided in roads.

## **PART-C**

**Answer shortly**

**(10 marks each)**

- 1) What are the uses of roads?
- 2) Explain the history of road development in India?
- 3) Explain Nagpur plan?
- 4) What are the purposes of soil stabilisation?
- 5) Write the merits and demerits of cement concrete road?
- 6) What are the uses of road Arboriculture?
- 7) What are the objectives of providing traffic signals?
- 8) What are the purposes for which traffic signals are provided?

## **PART-D**

**Answer in detail**

**(20 marks each)**

- 1) Classify the roads according to administration. Explain in detail.
- 2) What are the tests to be conducted for road aggregates? Explain in detail.
- 3) Explain the construction procedure for Earthen road with a neat sketch.
- 4) Explain the construction procedure for WBM road with a neat sketch.
- 5) Explain the construction procedure for Bitumen road with a neat sketch.
- 6) Explain the construction procedure for Concrete road with a neat sketch.
- 7) State the causes for accidents on roads and explain the safety measures adopted to prevent accidents.

**Answers :**    1) a    2) b    3) a    4) a    5) d





## Part B

ANSWER ANY TEN IN ONE (OR) TWO SENTENCES

10 x 4 = 40

31. Distinguish between enamel paint and cement paint?
32. What are the requirements of good roof?
33. Match the following
  - a) Easy chair - entertainment
  - b) Teapoy - placing articles and music system
  - c) Table and chair - relaxation
  - d) Radio and television - necessary hospitality to guests
  - e) Built in cupboard - studying
34. What are the types of Filtration?
35. Write the need for ventilation of sewers.
36. What are the principles of design?
37. What are the uses of surveying?
38. What is the need for a change point in levelling
39. What is meant by most economical cross-section of a channel?
40. What are the uses of air vessels?
41. Classify the roads according to materials used?
42. Draw any two cautionary signs which are provided in roads.

## Part C

ANSWER ANY FIVE SHORTLY

5 x 10 = 50

43. Explain the procedure of painting old & new iron and steel works.
44. Write the important points followed while constructing a kitchen in a house
45. Discuss the need for protected water supply and importance of public water supply scheme?
46. Write about selection of colours at home? Explain.
47. Explain with neat diagram the construction and working of an optical square.
48. What are the types of flow through pipes? Explain.
49. What are the purposes of soil stabilisation?

## Part D

4 x 20 = 80

### ANSWER ANY FOUR IN DETAIL

50. Explain the types of paints and their uses.
51. What is meant by per capita demand of water and explain the factors affecting the per capita demand.
52. Define Air pollution. Explain its effect on human being, plants, materials, animals?
53. The following staff readings have been taken during levelling

0.430   1.110   2.010   1.680

2.110   1.810   0.495   0.680

1.810   1.460   0.485   0.980

0.415

The instrument has been shifted after second, fifth, seventh and tenth readings. Enter the readings in level book form and reduce the level by any one of the method. The R.L of the point of first reading is +30.000. Do the arithmetical check

54. Find the quantity of water discharge through a rectangular channel 8m wide for uniform flow at a depth of 3m. The channel is having bed slope as 1 in 1000. Assume Chezy's constant  $C=55$ .
55. Explain the construction procedure for W.B.M road with neat sketch?

## BLUE PRINT OF QUESTION PAPER

Sl. No.	Subject	QUESTION ALLOTMENT				Remarks
		Part - A	Part - B	Part - C	Part - D	
		one Marks	Four Marks	Ten Marks	Twenty Marks	
1.	<b>BUILDING CONSTRUCTION</b>	5	2	1	1	
2.	<b>PLANNING OF HOUSE</b>	2	1	1	-	
3.	<b>WATER SUPPLY ENGINEERING</b>	5	1	1	1	
4.	<b>SANITARY ENGINEERING</b>	4	1	-	1	
5.	<b>AESTHETICS</b>	2	1	1	-	
6.	<b>SURVEYING</b>	4	2	1	1	(Problems only)
7.	<b>HYDRAULICS &amp; HYDRAULIC MACHINERY</b>	4	2	1	1	(Problems only)
8.	<b>HIGHWAY ENGINEERING</b>	4	2	1	1	
	<b>TOTAL NUMBER OF QUESTIONS</b>	30	12	7	6	