

BIOCHEMISTRY
HIGHER SECONDARY - SECOND YEAR

Untouchability is a sin
Untouchability is a crime
Untouchability is inhuman

TAMIL NADU
TEXT BOOK CORPORATION
College Road, Chennai - 600 006

© Government of Tamilnadu
First Edition - 2005

Chairperson

Dr.D. Sakthisekaran

Professor of Biochemistry, University of Madras,
Taramani Campus, Chennai - 600 113

Reviewers

Dr.P. Samudram

Asst.Prof. of Biochemistry (Retd.)
Institute of Biochemistry
Madras Medical College
Chennai - 600 003

Dr.(Mrs.) C.S. Shyamala Devi

Prof. and Head (Retd.)
Dept.of Biochemistry
University of Madras
Guindy Campus, Chennai -25

Dr.(Mrs.) P. Varalakshmi

Professor & Head, Dept. of Medical Biochemistry
University of Madras, Taramani Campus, Chennai - 600 113

Authors

Dr.(Mrs.) A.Geetha

Reader in Biochemistry
Bharathi Women's College
Chennai - 600 108.

Thiru. P.N. Venkatesan

P.G.Assistant
Govt. Higher Secondary School
Paradarami, Vellore - 632 603

Dr.(Mrs.) R. Sheela Devi

Lecturer , Dept. of Physiology
University of Madras
Taramani Campus, Chennai -113.

Dr. S. Subramanian

Lecturer, Dept. of Biochemistry
University of Madras
Guindy Campus, Chennai - 25.

Dr. (Mrs.) P. Kalaiselvi

Lecturer, Dept. of Medical Biochemistry
University of Madras, Taramani Campus, Chennai - 600 113

Price : Rs.

This book has been prepared by the Directorate of School
Education on behalf of the Government of Tamilnadu

This book has been printed on 60 GSM Paper

Printed by Offset at:

CONTENTS

	Page
1. Cell Membrane	1
2. Digestion	27
3. Carbohydrate Metabolism	43
4. Protein Metabolism	73
5. Lipid Metabolism	101
6. Nucleic acid Metabolism	121
7. Inborn Errors of Metabolism	143
8. Biological Oxidation	157
9. Enzyme Kinetics	179
10. Immunology	199
11. Practicals	233

CHAPTER I

Cell Membrane

Introduction

The outer living boundary of the cell is called as the cell membrane or 'Plasma membrane'. The term cell membrane was coined by C.J. Nageli and C. Crammer in 1855. Apart from the cell membrane, each and every organelle in the cell is also covered by membranes. The cell membrane not only limits the cell cytosol, but it has a variety of functions like membrane transport, signal transduction and neuro transmission.

1.1 Chemical Composition

To study the chemical composition of the cell membrane, the preferred source is RBC, because they lack cell organelles and thus no contamination of other cellular organelle membranes. The membranes of the RBCs devoid of cytosol are called as 'ghosts'.

Four major constituents are present in the cell membrane. They are (i) lipids (28 – 79%) (ii) proteins (20 – 70%). (iii) oligosaccharides (only 1 – 5%) and (iv) water (20%).

1.1.1 Lipids

Depending upon the tissue from which the cell membrane is isolated, the composition also differs. Nearly 80% of the myelin sheath is made up of lipids, while in liver, it constitutes only 28%.

The main lipid components of the membranes are phospholipids, cholesterol and glycolipids. The major phospholipids present are phosphatidyl choline (lecithin), phosphatidyl ethanolamine, phosphatidyl serine and phosphatidyl inositol.

Membrane lipids are amphipathic in nature and they have a head portion, which is hydrophilic and a tail portion which is hydrophobic. As the membranes are exposed to the hydrophilic environments, the lipids arrange themselves to form a bilayer in which the hydrophobic core is buried inside the membrane.

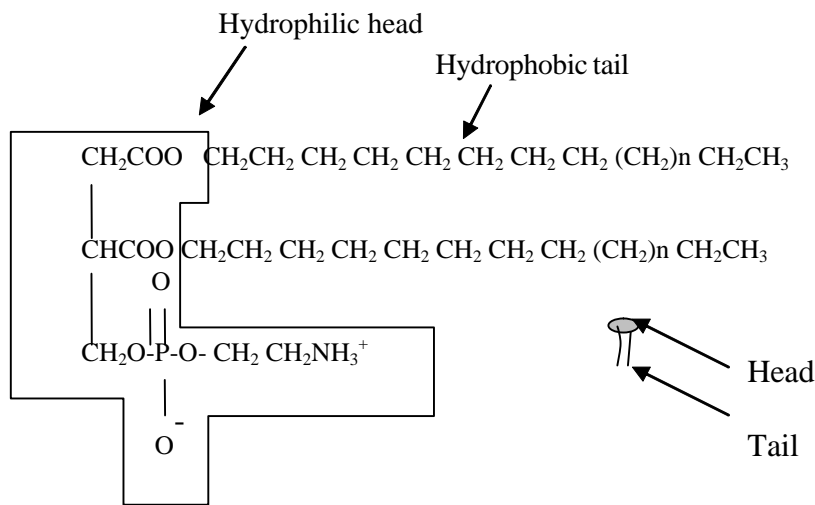

Structure of phospholipid

1.1.2 Proteins

All the major functions of the plasma membrane are executed by the proteins present in the membrane. Proteins account for about 20 – 70% of the membrane depending on the type of the cell. They can be classified into two types. Integral membrane proteins and peripheral membrane proteins.

Integral Proteins

Some of the membrane proteins are tightly embedded in the membrane and they cannot be isolated unless, the membrane is disintegrated. They are called as Integral or Intrinsic membrane proteins. They are again classified into two. (a). Transmembrane proteins, which traverse (pass through) or span the membrane. These proteins will have domains on either side of the membrane. Many cell surface receptors belong to this class. (b). Lipid anchored proteins that are present either on the cytosolic side or on the extracytosolic side. They insert themselves in the membrane by a lipid (acyl chain) attached to the N terminal end.

Transmembrane proteins are of two types. Single pass transmembrane proteins that traverse the membrane only once. Multipass transmembrane proteins that traverse the membrane more than once.

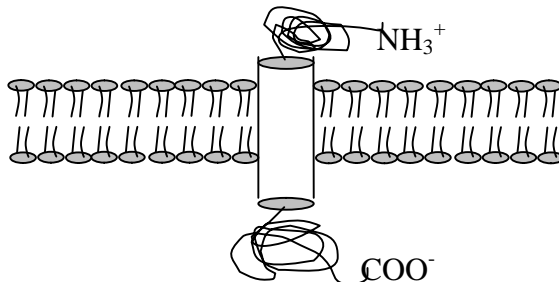

Fig. 1.1 Single pass transmembrane Protein

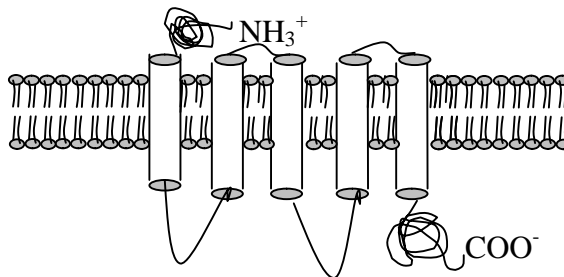

Fig. 1.2 Multipass transmembrane Protein

Peripheral Proteins

Those proteins that are present on the surface of the membrane are called as peripheral proteins. They can be easily isolated from the membrane. eg. spectrin present in the RBC membrane.

1.2 Models proposed for the plasma membrane

1.2.1 Monolayer Model

Overton was the pioneer to postulate that plasma membrane is a thin layer of lipid. He proposed this because he found that lipid soluble substances are easily transported across the membrane.

1.2.2 Lipid Bilayer Model

The amount of lipids present in the erythrocyte membrane was nearly twice that of its total surface area. This made Gorter and Grendel to propose that lipids in the membrane exist as bilayers.

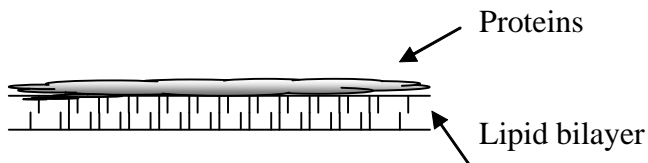

Fig. 1.3 Lipid bilayer membrane model

1.2.3 Unit Membrane Model

This model was proposed by Davson and Danielli and was shaped by Robertson. Experiments showed that the surface tension of the biological membranes are lower than that of the pure lipid bilayers, suggesting the presence of proteins in them. Based upon this, Davson and Danielli proposed that proteins are smeared over the lipid bilayer.

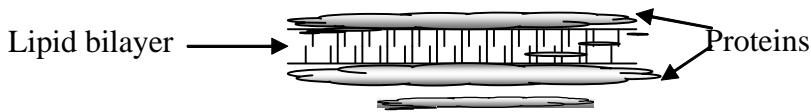

Fig. 1.4 Unit membrane model

When electron microscope was invented, plasma membrane appeared as three layers. With this observation, Robertson formulated a unit membrane model, which states that the proteins are present on either side of the lipid bilayer. According to this model, the membrane will be like a lipid layer sandwiched between two protein layers.

1.2.4 Fluid Mosaic model

This is the universally accepted model for plasma membrane. On the basis of several experiments, S.J. Singer and G.L. Nicolson in 1972 proposed this model.

The essential features of the Fluid mosaic model are

1. Lipids and proteins are present in a mosaic arrangement within the bilayer.
2. Phospholipids act as a fluid matrix, in which some proteins are integral and others are associated with the surface of the membrane.
3. Lipids and proteins are mobile in the membrane.
4. They can move laterally, rotate but not from one monolayer to the other.
5. The membrane is asymmetric in nature, the outer and inner leaflets of the bilayer differ in composition.

1.3 Membrane Transport

One of the vital functions of the plasma membrane is membrane transport. Such a transport is important to carry out the life processes of the cell. Hydrophobic molecules and small polar molecules rapidly diffuse

in the membrane. Uncharged large polar molecules and charged molecules do not diffuse and they need proteins to get transported.

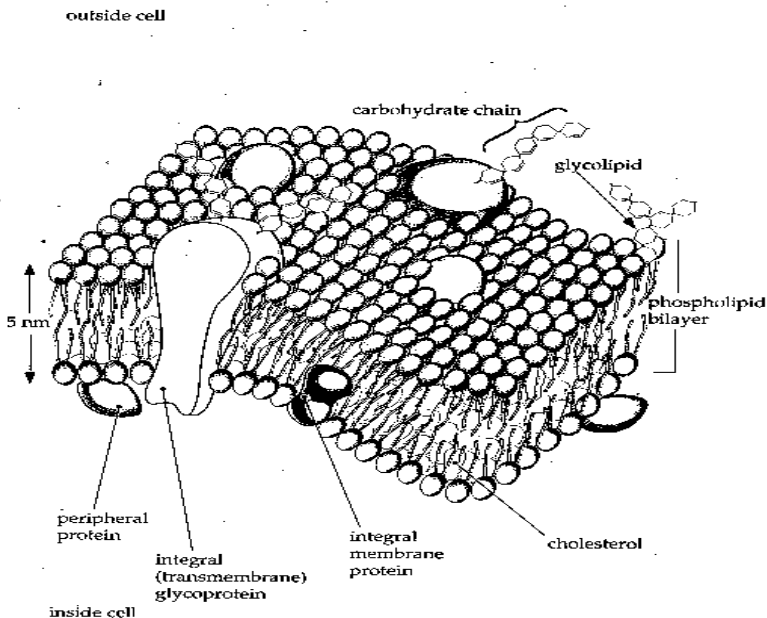

Fig. 1.5 Fluid Mosaic model of cell membrane

Depending upon the energy required and movement of the solute for or against the concentration gradient, the transport can be classified into two, active transport and passive transport.

1.3.1 Passive transport

Passive transport is also called as passive diffusion. In passive transport, the substances move from higher concentrations to lower concentrations generally without the help of any protein. The transport

continues until the concentration of the substance becomes same on both the sides of the membrane. O₂, CO₂ and urea can easily diffuse across the membrane.

1.3.2 Facilitated Diffusion

Eventhough, the concentration of certain hydrophilic substances like glucose are high across the membrane, they cannot pass through the membrane and need a carrier for their transport. Such a transport is called as facilitated diffusion. The proteins involved in such processes are called as carrier proteins. Carrier proteins are present in all biological membranes. Some important characteristics of carrier proteins are

1. They facilitate transport from high concentrations of the solute to low concentrations.
2. They speed up the process of attaining equilibrium
3. They do not need energy for their transport.
4. They are highly specific in nature.

Some common examples are glucose transporter and anion transporters in red blood cell membranes.

Carrier proteins are classified into three major types.

1. Uniporters that transport single solute from one side of the membrane to the other.
2. Symporters that transport two different solute molecules simultaneously in the same direction.
3. Antiporters that transport two different solute molecules in opposite directions.

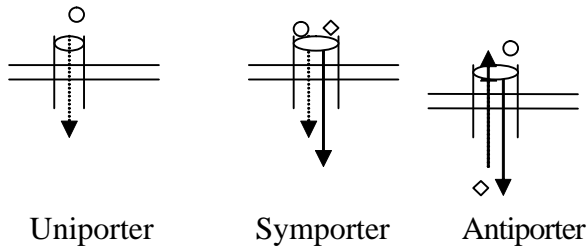

1.3.3 Active transport

Cells have to transport substances against the concentration gradient, i.e. from low concentrations to high concentrations. This transport called active transport is a thermodynamically unfavourable reaction. Hence, it needs energy to drive the reaction which is acquired by ATP hydrolysis. Active transport is also mediated by carrier proteins and they are called as pumps. Na^+K^+ ATPases that is required to maintain the potassium concentration high inside the cell and sodium concentrations low is an example for pumps.

1.3.4 Endocytosis

Endocytosis is the active process of engulfing large size particles of food substances or foreign substances. Depending upon the nature of the material that is ingested, endocytosis may be classified into two. Pinocytosis, in which the fluid material is engulfed and phagocytosis, in which large sized solid material is engulfed.

During the process, the plasma membrane invaginates into tiny pockets, which draw fluids from the surroundings into the cell. Finally, these pockets pinch off and are known as pinosomes or phagosomes, which fuse with lysosomes and liberate their contents into the cell cytosol.

Exocytosis is the process of exuding the secretory products from the cells. Vesicles containing secretory materials fuse with the plasma membrane and discharge their contents into the exterior. Pancreatic cells pass out their enzyme secretions to the exterior by exocytosis.

Table 1 Similarities and differences between facilitated diffusion and active transport

Facilitated Diffusion	Active Transport
1. Needs a carrier protein and they are named as transporters or channels.	Needs a carrier protein and they are named as pumps
2. Highly specific in nature	Highly specific in nature
3. Saturable	Saturable
4. Inhibited by competitive inhibitors	Inhibited by competitive inhibitors
5. Solutes are transported from high concentrations to low concentrations	Solutes are transported from low concentrations to high concentrations
6. No energy is needed.	Energy is needed.

1.4 Viscosity

If two tubes, one containing water and the other containing castor oil are tilted together, the latter will flow slowly, when compared to the former. This is because of the frictional force that exists between liquid layers. This resistance for the flow of the liquid is termed as Viscosity.

Viscosity is defined as the internal resistance against the free flow of a liquid to the frictional forces between the fluid layers moving over each at different velocities. Each and every liquid has its own characteristic viscosity co-efficient. The co-efficient of viscosity of a liquid is defined as the force in dynes required to maintain the streamline flow of one fluid layer of unit area over another layer of equal area separated from one another by 1 cm at a rate of 1cm/sec. Viscosity is measured in poises or millipoises.

1.4.1 Factors affecting viscosity

1. Density

Density and viscosity are directly proportional to each other. They are related by Stoke's law. If a small sphere of radius 'r' and density 'ρ' falls vertically through a liquid with the density 'ρ'' at a steady velocity 'u', inspite of the acceleration due to gravity (g), the co-efficient of viscosity and density are related as follows.

$$\eta = \frac{2r^2g(\rho - \rho')}{9u}$$

2. Temperature

Temperature and viscosity are inversely related to each other. As temperature increases, viscosity of the liquid decreases.

3. Solute

Dissolved substances in the pure solvent increases the viscosity of the solvent. For eg. a protein solution is highly viscous than pure water. Size and Shape of the solute particles also affect the viscosity of the solution.

1.4.2 Biological Applications

1. Carbohydrate and protein solutions are highly viscous in nature.
2. Blood plasma has a normal viscosity of 15 – 20 mpoises. Alterations in the viscosity is an indication of diseased condition. Viscosity increases during macroglobulinemia, retinal hemorrhages and congestive heart failure.
3. Viscosity of blood is 30 – 40 mpoises and is due to the red blood cells. Viscosity of blood decreases during anemia.
4. Blood viscosity is useful in streamlining the blood flow.
5. The lubricating property of the synovial fluid is achieved mainly by the viscous nature of the mucopolysaccharides present in the synovial fluid.

1.5 Surface tension

A molecule inside the liquid mass (a) is pulled uniformly on all the sides by intermolecular forces. But a surface molecule (b) suffers a much greater intermolecular attraction towards the interior of the liquid than towards the vapour phase, because fewer molecules are present in the vapour phase. The excess of inward force on the surface layer accounts for the surface tension. Surface tension (γ) is defined as the force acting perpendicularly inwards on the surface layer of a liquid to pull its surface molecules towards the interior of the liquid mass.

1.5.1 Factors affecting surface tension

1. Density - Macloed's equation relates surface tension to the density of the liquid (ρ) and that of its vapour (ρ').

$$\gamma \propto (\rho - \rho')^2.$$

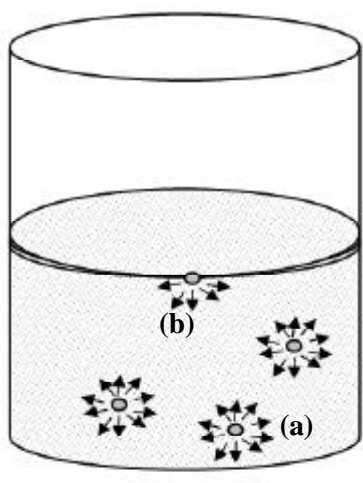

Fig. 1.6 Unequal force of attraction experienced by a surface molecule

2. **Temperature-** Temperature and surface tension are inversely related to each other. As the temperature of the liquid increases, the surface tension decreases and becomes zero at the critical temperature.
3. **Solutes -** Solutes that enter the liquid raise the surface tension of the solvent, while solutes that concentrate on the surface lower the surface tension.

1.5.2 Biological Importance

1. **Emulsification of fats by bile salts -** Bile salts lower the surface tension of the fat droplets in the duodenum, which aids in digestion and absorption of lipids.
2. **Surface tension of plasma:** The surface tension of plasma is 70 dynes/cm, which is slightly lower than that of water.
3. **Hay's test for bile salts -** The principle of surface tension is used to check the presence of bile salts in urine. When fine sulphur

powder is sprinkled on urine containing bile salts (as in jaundice), it sinks due to the surface tension lowering effect of bile salts. If there are no bile salts in urine as in normal individuals, it floats.

4. Dipalmitoyl lecithin is a surfactant that is secreted by the lung alveoli, which reduces the surface tension and prevents the collapse of lung alveoli during expiration. Certain pre-mature infants have low levels of this surfactant leading to acute respiratory distress.

1.6 Osmosis

If a protein solution is separated by a semipermeable membrane from pure water, water tends to flow from the latter to the former. The property of the movement of solvent particles is called as osmosis. Osmosis is the net diffusion of water from the dilute solution to the concentrated solution. Osmosis is a colligative property of solution that depends on the number of molecules or ions of the solute in the solutions. Osmol units give the number of osmotically active particles per mole of a solute. Each mole of a non-ionized solute is equivalent to 1 osmol. Osmolarity of a solution is its solute concentration in osmols/litre. Osmolality of a solution is its solute concentrations in osmols/kg of the solvent.

Two solutions with identical osmotic pressures are called as iso-osmotic solutions. A solution having lower or higher osmotic pressure with respect to the other is called as hypo-osmotic or hyperosmotic solutions respectively.

The plasma membrane is a semipermeable membrane and it allows only certain solutes to diffuse. The osmotic pressure exhibited by these impermeable solutes is called as the tonicity of the solution. Tonicity is an important physiological parameter.

Two solutions with identical tonicities are called as isotonic solutions. A solution having lower or higher tonicities with respect to the other is called as hypotonic or hypertonic solutions respectively.

1.6.1 Biological Significance

1. Hemolysis and Crenation. The physiological or isotonic saline is 0.9% NaCl. When red blood cells are suspended in 0.3% NaCl (hypotonic solution), water will enter into the cells and the cell will burst releasing all its contents. This kind of lysis is called as hemolysis. The resulting membranes are called as ghosts. On the other hand, when the cells are placed in 1.5% NaCl, water comes out of the cell, leading to shrinkage of cells. The process is called as crenation.
2. The erythrocyte fragility test is based upon the osmotic diffusion property. The ability of the membrane to withstand hypotonic solution depends upon the integrity of the membrane. Certain genetic disorders like sickle cell anemia and deficiency of vitamin E makes the erythrocyte membrane more fragile.
3. Osmotic pressure of blood is largely due to its mineral ions such as sodium, potassium, chloride, calcium and protein. The osmotic pressure exerted by proteins is of considerable biological significance owing to the impermeability of the plasma membrane to the colloidal particles.
4. Absorption of water in the intestine is due to osmosis. Formation of urine in the kidneys may be attributed to osmotic pressure. The net difference in the hydrostatic pressure and osmotic pressure is responsible for the filtration of water at the arterial end of the capillary and the reabsorption of the same at the venous end. At the arterial end, the hydrostatic pressure is 22 mmHg and the osmotic pressure is 15 mm Hg. The pressure to drive out the fluid is 7 mm Hg. At the venous end, the hydrostatic pressure is 15 mm Hg and osmotic pressure is 7 mm Hg. The net absorption pressure to draw water back into the capillaries is $15 - 7 = 8$ mm Hg. This is called as Starling's hypothesis.

5. The renal excretion of water is regulated partly by the osmotic pressure exerted by the colloids in the blood plasma. Increased urination (polyuria) occurring in diabetes patients is due to the increased water retention by the urinary glucose.

6. **Donnan Membrane Equilibrium**

Let us consider two compartments separated by a semi permeable membrane, which is permeable to water and crystalloids, but not to colloidal particles. One of the compartment (A) is filled with a moles of NaCl, and the other compartment (B) is filled with b moles of NaR, in which R happens to be a non diffusible ion.

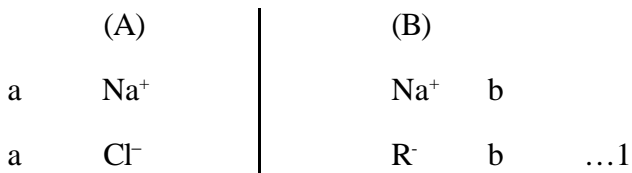

NaCl diffuses from (A) to (B) and after some time, the system attains equilibrium. At equilibrium, let us consider that x moles of NaCl have diffused from (A) to (B). So, the ionic concentration at equilibrium in both the compartments will be as follows,

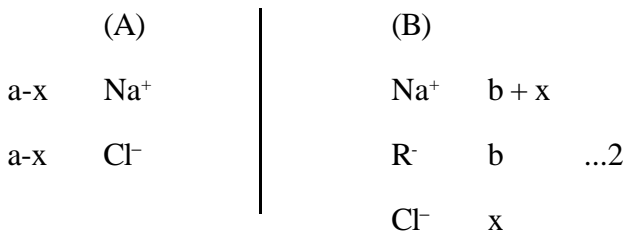

At equilibrium, the number of ions that move from one compartment to other will be equal, and this will occur only, when the ionic products of the concerned ions are equal.

Therefore, $[\text{Na}^+][\text{Cl}^-]$ in both the compartments at equilibrium should be equal.

$$(a-x)(a-x) = (b+x)x$$

$$(a-x)^2 = bx + x^2$$

$$a^2 - 2ax + x^2 = bx + x^2$$

$$a^2 - 2ax = bx$$

$$a^2 = bx + 2ax$$

$$a^2 = (b + 2a)x$$

$$x = \frac{a^2}{(b + 2a)}$$

On substituting numerical values for a and b as 2 and 1 moles respectively,

$$x = \frac{2^2}{1 + (2 \times 2)}$$

$$= \frac{4}{5}$$

$$= 0.8$$

Calculating the total moles present in compartment (A) and (B) at equilibrium.

(A)				(B)
$2 - 0.8 = 1.2$	Na^+		Na^+	$1 + 0.8$
$2 - 0.8 = 1.2$	Cl^-		R^-	1
			Cl^-	0.8
2.4				3.6

From this we can derive that:

- (i) The concentration of solutes in the non-diffusible ion side (B) is greater than the other.
- (ii) There will be accumulation of the oppositely charged ion (Na^+) in the side containing the non-diffusible ion (R^-).

In biological systems, Donnan membrane equilibrium prevails due to the non-diffusible proteins and is also significant for the functional aspects of the cell.

If the non-diffusible ion happens to be R^- and one of the diffusible ion H^+ , then there will be a change in the pH. Due to imbalance in the electrolytes, swelling of proteins occur, which is called as Donnan osmotic effect.

1.7 Buffers

A buffer may be defined as a solution which resists the change in pH that will occur on addition of small quantities of acid or base to the solution. Buffers are mixtures of weak acid and its salt or weak base and its salt. The pH of the solution is defined as the negative logarithm of hydrogen ion concentration. The pH of buffers are determined by Henderson Haselbach equation, which is derived as follows

Let us consider a weak acid that ionizes as follows

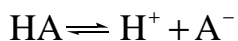

Then equilibrium constant K will be

$$K_a = \frac{[\text{H}^+][\text{A}^-]}{[\text{HA}]}$$

Rearranging the equation, we get,

$$K_a [\text{HA}] = [\text{H}^+][\text{A}^-]$$

$$[\text{H}^+] = \frac{K_a[\text{HA}]}{[\text{A}^-]}$$

Taking log on both the sides,

$$\log [\text{H}^+] = \log K_a + \log \frac{[\text{HA}]}{[\text{A}^-]}$$

Multiplying by -1, we get

$$-\log [\text{H}^+] = -\log K_a - \log \frac{[\text{HA}]}{[\text{A}^-]}$$

$$\boxed{\text{pH} = \text{p}K_a + \log \frac{[\text{A}^-]}{[\text{HA}]}}$$

The pH of blood is 7.4 and it should be maintained constant. If pH increases above 7.5, alkalosis occurs and beyond 7.8 death occurs.

If it falls below, 7.3, acidosis occurs and below 7.0 is incompatible for life. Due to metabolism and dietary intake, large quantities of acids and bases are produced in the body and they have to be transported through blood for elimination. This should occur without any major changes in the pH. This is effectively done in the body by means of the buffers present in the blood and by two mechanisms, namely the respiratory mechanism and the renal mechanism.

The buffer systems of blood are as follows

Plasma	Erythrocytes
$\frac{\text{H}_2\text{CO}_3}{\text{BHCO}_3}$	$\frac{\text{H}_2\text{CO}_3}{\text{BHCO}_3}$
$\frac{\text{H.Protein}}{\text{B.Protein}}$	$\frac{\text{H.Hb}}{\text{B.Hb}}$
$\frac{\text{BH}_2\text{PO}_4}{\text{B}_2\text{HPO}_4}$	$\frac{\text{H.Hb O}_2}{\text{B.Hb O}_2}$
$\frac{\text{H.Organic acid}}{\text{B.Organic acid}}$	$\frac{\text{BH}_2\text{PO}_4}{\text{B}_2\text{HPO}_4}$
	$\frac{\text{H.Organic acid}}{\text{B.Organic acid}}$

The numerators are acid components and the denominators are salts.

Since the concentrations of phosphate and organic acids are low in plasma, they do not play a major role in regulation of pH.

The major buffer in plasma is bicarbonate buffer and the pKa of carbonic acid is 6.1. Substituting it in the Henderson Hasselbach equation,

$$7.4 = 6.1 + \log \frac{\text{BHCO}_3}{\text{H}_2\text{CO}_3}$$

$$7.4 - 6.1 = \log \frac{\text{BHCO}_3}{\text{H}_2\text{CO}_3}$$

$$1.3 = \log \frac{\text{BHCO}_3}{\text{H}_2\text{CO}_3}$$

Since antilog of 1.3 is 20,

$$\frac{\text{BHCO}_3}{\text{H}_2\text{CO}_3} = \frac{20}{1}$$

To effectively maintain the pH of blood, according to Henderson Hasselbach equation, the ratio of bicarbonate to carbonic acid should be 20 : 1. The carbon dioxide produced by metabolism is buffered by the hemoglobin buffer system as follows.

Hemoglobin buffer system

The buffering capacity of hemoglobin is due to the presence of imidazole groups in its histidine residues. The degree of dissociation of the imidazole groups is dependant upon the degree of oxygenation of Hb. If hemoglobin is oxygenated, it is more acidic and therefore exists in its dissociated form. When it is not bound with oxygen, it will be in the reduced form.

In the tissues, where oxygen tension is reduced, HbO_2 dissociates to give oxygen to the tissues. In turn, the CO_2 produced in the tissues will combine with H_2O to form H_2CO_3 , which dissociates to H^+ and HCO_3^- . The reduced Hb devoid of O_2 combines with H^+ ions to form HHb resulting a very little change in the pH.

When the blood returns to the lungs, O_2 tension in the lungs is high resulting in the oxygenation of Hb. As mentioned earlier, HbO_2 has lesser affinity to H^+ and releases it. It combines with HCO_3^- ions to form H_2CO_3 that dissociates to H_2O and CO_2 .

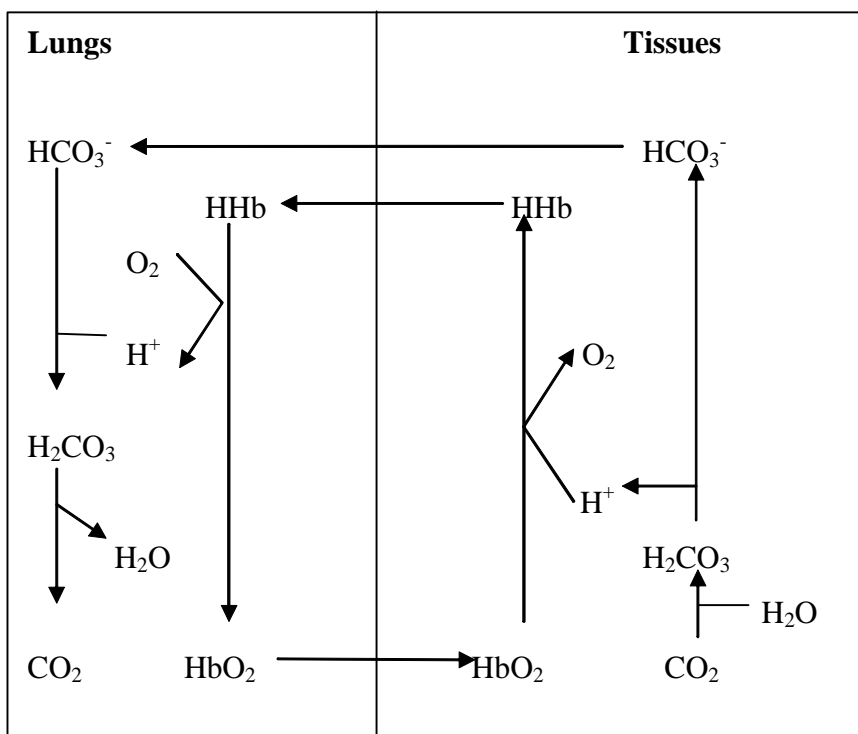

Fig. 1.7 Buffering action of Hemoglobin

It has been found that more than 80% of the buffering capacity of blood is due to red blood cells. But the buffered HCO_3^- is transported in the plasma. The process of transport of the formed HCO_3^- from the RBCs into the plasma needs chloride ions and the phenomenon is called as Hamberger's chloride bicarbonate shift.

When CO_2 liberated from the tissues enters the RBC via plasma, it combines with water to form carbonic acid, the reaction catalysed by an enzyme called as carbonic anhydrase. The same enzyme can also dissociate carbonic acid to carbon dioxide and water. Carbonic acid dissociates into HCO_3^- and H^+ ions.

The formed bicarbonate is exchanged for one chloride ion with the plasma. The chloride that enters the cell forms neutral potassium chloride in the cell. The bicarbonate that enters the plasma reacts with the sodium ions to form sodium bicarbonate. Thus, the bicarbonate ions are transported in the plasma.

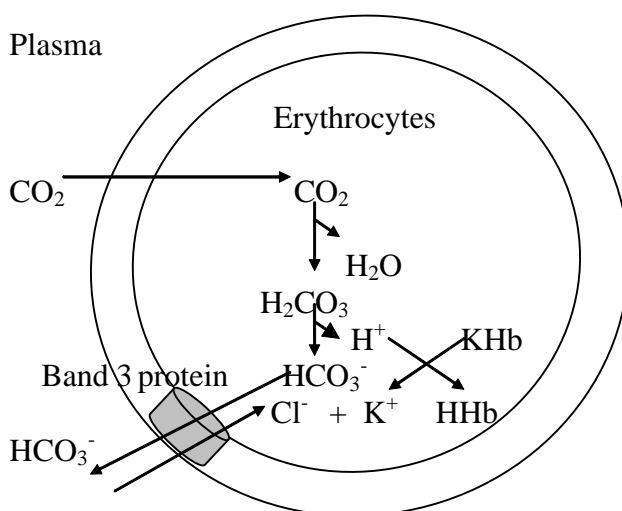

Fig. 1.8 Hambergers Chloride Bicarbonate Shift

Regulation by Respiratory mechanism

Respiratory mechanism plays an important role in the regulation of acid-base balance because the respiratory centre is sensitive to the changes in $p\text{CO}_2$.

If there is an increase in $p\text{CO}_2$, increased respiration occurs, helping to remove the excess CO_2 . This continues until the blood regains normal $p\text{CO}_2$ and pH. Similarly a fall in the $p\text{CO}_2$ leads to slow, shallow respiration, hypoventilation and retention of CO_2 .

Regulation by renal mechanism

The lungs can remove only volatile acids like CO_2 but not the organic acids like lactic acid and pyruvic acids. These acids are effectively buffered by the bicarbonate system, but at the expense of the bicarbonate, which is called as the alkali reserve of the body. Lungs can eliminate H_2CO_3 , but cannot restore bicarbonate. This is done by the kidneys, which are the ultimate regulators of acid base balance. In acidemia, in order to bring the low pH to normal, the excessive H^+ ions should be excreted and bicarbonate excretion should be reduced. This is done by excreting a highly acidic urine (pH 4.5). On the other hand, during alkalemia, the kidneys excrete the excess bicarbonate producing an alkaline urine (pH 8.2). The three important mechanisms attributed by the kidneys to regulate the blood pH are

- (i) Reabsorption of bicarbonate
- (ii) Buffering by phosphate buffers
- (iii) Formation of ammonium ions.

Exercises

I Choose the correct answer from the four alternatives

- a. The term cell membrane was coined by
1. C.J. Nageli and Crammer
 2. Singer and Nicolson
 3. Robertson
 4. Gorter and Grendel
- b. Proteins are needed for
1. Facilitated diffusion
 2. Passive transport
 3. both of them
 4. None of the above
- c. The pH of blood is
1. pH 7.4
 2. pH 6.1
 3. pH 1.3
 4. pH 4.7
- d. The major buffer system of the red blood cells are
1. Phosphate buffer
 2. Hemoglobin buffer
 3. Carbonate buffer
 4. Acetate buffer
- e. The unit of viscosity is
1. Osmols
 2. Poises
 3. Dynes
 4. Newtons

II. Fill up the blanks

1. Two solutions with identical osmotic pressures are called _____.
2. The proteins that are tightly embedded in the membrane are called as _____.
3. The red blood cell membrane devoid of cytosol are called as _____.
4. The lubricating property of the synovial fluid is due to the presence of _____ in it.
5. The non-volatile acids are buffered by _____ mechanism.

III. Say true or false

1. Carbohydrates are the major components of the cell membrane.
2. Facilitated diffusion is an energy dependant process.
3. Viscosity of blood is increased during anemia.
4. The buffering action of hemoglobin is due to the lysine residues present in it.
5. When RBCs are placed in hypotonic solution, crenation occurs.

IV. Match the following

- | | | |
|-------------------------------|---|----------------------|
| 1. Erythrocyte Fragility Test | - | Surface tension |
| 2. Hays test | - | Dipalmitoyl lecithin |
| 3. Surfactant | - | Osmosis |
| 4. Unit membrane model | - | Nicolson |
| 5. Fluid mosaic model | - | Robertson |

V. Give one word answer

1. Give one example for peripheral proteins.
1. What is the viscosity of blood?
2. How are fluids absorbed into the cell?
3. Name the protein that exchanges chloride and bicarbonate ions in red blood cells.
4. Which ions will accumulate on the side containing a non-diffusible protein anion (R^-).

VI. Answer the following briefly

1. Give an account on membrane proteins.
2. Briefly discuss the various models proposed for cell membranes.
3. List the biological applications of surface tension and viscosity.
4. How is CO_2 transported in the blood without any change in the blood pH?
5. Write briefly on Donnan Membrane Equilibrium.

CHAPTER II

Digestion

Introduction

The conversion of food into a form that can be absorbed by the body is called digestion. It describes how the body breaks down food and uses it for energy, cell repair and growth. It starts in the mouth, continues in the stomach and small intestine and is completed in the large intestine. The liver and pancreas add enzymes and juices that aid in this process. Carbohydrates are broken down to glucose, proteins to amino acids, fats to glycerol and fatty acids.

2.1 Carbohydrates

The major carbohydrates present in our diet are starch, glycogen, sucrose, lactose, maltose and very little concentrations of fructose and pentose.

2.1.1 Digestion in mouth

Milk and other fluid items like juices escape digestion in the mouth as they do not reside in the mouth for a longer time, whereas, starch and glycogen containing solid foods are masticated with saliva thoroughly. Saliva contains ptyalin, an α amylase, which attacks the α 1-4 linkages resulting in the formation of monosaccharide glucose, disaccharide maltose and trisaccharide maltotriose. However, because of steric hindrance caused by the branches, some of the interior α 1-4 linkages are inaccessible for the enzyme. This results in the formation of a highly branched structure called as limit dextrin.

The optimum pH for salivary amylase is pH 6.7. Ptyalin needs chloride ions for their effective action.

Glycogen, Starch \longrightarrow Glucose, Maltose, Maltotriose, Limit Dextrin

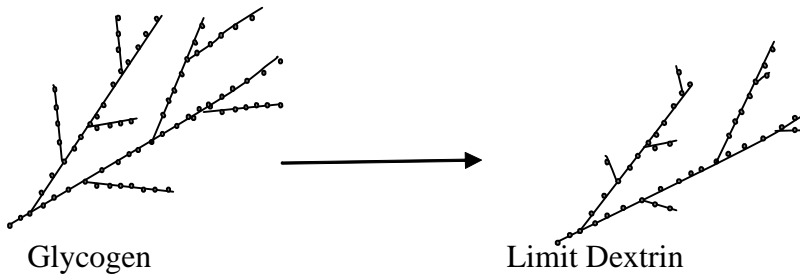

When food along with ptyalin reaches the stomach, ptyalin is inactivated due to low pH. There are no enzymes to act upon carbohydrates in the stomach. No change to polysaccharides occurs in the stomach. Dietary sucrose may be hydrolyzed to equimolar quantities of glucose and fructose by the HCl present.

2.1.2 Digestion in duodenum

When the food bolus reaches the duodenum, it is mixed with the pancreatic juice, which contains α amylase. Its action is similar to that of the ptyalin, but it is more powerful because

- (i) It can act upon raw starch.
- (ii) It can hydrolyze the interior linkages of the starch, which were inaccessible for ptyalin.

The optimum pH of pancreatic amylase ranges between 6.9 – 7.1 and it needs chloride ions for its action

2.1.3 Digestion in small intestine

Five enzymes are present in small intestine to hydrolyze the carbohydrates completely to monosaccharides.

a. **Intestinal amylase** : It hydrolyses the terminal α 1-4 linkages in polysaccharides and oligosaccharides releasing free glucose molecules.

b. **Lactase** : It is a β -galactosidase that hydrolyses lactose molecule to equimolar amounts of glucose and galactose. Its optimum pH is 5.4 – 6.0



c. **Maltase** : It is a glucosidase that acts on α 1-4 linkages of maltose yielding glucose molecules. Five different maltases have been identified in the intestinal epithelial cells. Its optimum pH ranges between 5.8 – 6.2.



d. **Sucrase**: It hydrolyzes sucrose to equimolar amounts of glucose and fructose by hydrolyzing β 1-2 linkages.



e. **Isomaltase** : It hydrolyses the α 1-6 branch points of limit dextrin and liberates maltose and glucose.

There are no enzymes present in our digestive system to hydrolyze β 1,4 linkages in cellulose, so it cannot be digested.

2.1.4 Absorption of carbohydrates

Only monosaccharides can be absorbed by the intestinal mucosa. A few disaccharides can be pinocytosed and hydrolyzed to monosaccharides by disaccharidases. The absorption rate of the monosaccharides is in the following order:

Galactose > Glucose > Fructose > Mannose > Xylose > Arabinose

Mechanism of absorption

1. **Simple Diffusion:** Initially, when the concentration of glucose in the intestinal lumen is high, by simple diffusion it crosses the membrane.
2. **Active Transport:** To speed up the absorption process, active transport mechanisms are involved. Absorption of glucose is a secondary active transport process, which involves ATP hydrolysis indirectly.

The steps involved in the transport of glucose are :

- (i) One molecule of Na^+ and glucose binds to the transporter.
- (ii) Binding of sodium and glucose induces a conformational change in the transporter.

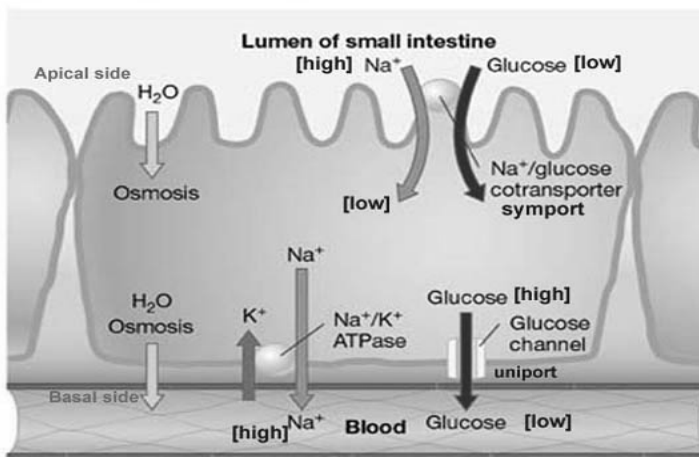

Fig 2.1 Model of glucose absorption

- iii) The conformational change leads to the delivery of sodium and glucose molecules to the intestinal cells.

- iv) Sodium is pumped out of the cell resulting in the net absorption of glucose molecule alone.

Step (iv) needs energy that is derived by ATP hydrolysis.

2.1.5 Factors affecting rate of absorption

1. If the intestinal mucosa is damaged, absorption is reduced.
2. Hormones like thyroid hormone, adrenal cortex hormones and pituitary hormones enhance the absorption of carbohydrates.
3. Insulin has no effect in the absorption of glucose.
4. Pyrimidine and pantothenic acid deficiencies diminish the absorption.
5. Inherited enzyme deficiency states like lactose intolerance decreases the absorption.

2.2 Proteins

Proteins in diet are from animal sources and vegetable sources. Animal sources like milk, dairy products, meat, fish, liver and eggs are rich sources of proteins.

Vegetable sources like cereals, pulses, peas, beans and nuts are rich in protein.

2.2.1 Digestion in mouth

There are no enzymes in mouth to degrade the protein.

2.2.2 Digestion in stomach

HCl : HCl secreted by the gastric mucosa destabilizes the secondary structures of the proteins such that it can be easily acted upon by the enzymes.

The proteolytic enzymes present in the gastric juice are pepsin, rennin, gastricin and gelatinase.

Pepsin : It is a potent proteolytic enzyme and is present in the gastric juices. It is secreted in the inactive zymogen form called as pepsinogen, which has a molecular weight of 42,500 daltons. In the acidic medium, pepsinogen is cleaved to pepsin and the reaction is favoured autocatalytically. Pepsin having a molecular weight of 34,500 daltons is an endopeptidase. An endopeptidase is an enzyme that acts on the peptide linkages in the interior of the protein.

Pepsin acts on protein to convert it to proteoses and peptones, which are low molecular weight peptides.



It has a broader specificity and acts on peptide linkages constituted by the carboxyl group of an aromatic / hydrophobic amino acid or amino group of a dicarboxylic acid.

It hydrolyzes the soluble casein in milk , which along with calcium forms insoluble paracaesinate.

The optimum pH for pepsin is 1.6 – 2.5

Rennin

Rennin is present in infants only and it is secreted by the gastric mucosa as pro –rennin. It is converted to active rennin by HCl. It also converts casein in milk to insoluble calcium paracaesinate.

2.2.3 Digestion in duodenum

The chief enzymes of the pancreatic juice that acts on proteins are a) trypsin b) chymotrypsin c) carboxy peptidase d) elastases and e) collagenases

Trypsin

Trypsin, a proteinase is secreted in the inactive zymogen form called trypsinogen. It is activated by enterokinase and also autocatalytically in the presence of calcium.

It is an endopeptidase that is specific for peptide linkages formed by carboxyl groups of basic amino acids, namely arginine, lysine. The hydrolytic products are polypeptides, proteoses, peptones, di and tri peptides. It cannot hydrolyze peptide linkages which involves proline.

It activates proelastase to elastase, chymotrypsinogen to chymotrypsin, fibrinogen to fibrin. The optimum pH for trypsin is 8 – 9.

Chymotrypsin

It is an endopeptidase, which is secreted in the inactive form as chymotrypsinogen. It is activated by trypsin and also autocatalytically. It hydrolyses peptide linkages with carboxyl group of aromatic amino acids like tryptophan, tyrosine and phenyl alanine.

The optimum pH for chymotrypsin is 7 - 8

Carboxy peptidase

Two types of carboxy peptidases, carboxy peptidase A and B are known. Carboxy peptidase A is a metallo enzyme that contains zinc. Both are exopeptidases. Carboxy peptidase A is specific for aromatic amino acids at the C terminal end, while carboxy peptidase B is specific for basic amino acids at the C terminal end.

The optimum pH for both of them lies between 7-8.

2.2.4 Digestion in small intestine

The proteolytic enzymes present in the intestinal juice are enterokinase, amino peptidase, prolidase and di and tri peptidases.

Enterokinase is an enzyme that activates trypsin in the presence of calcium. Aminopeptidases are capable of removing one amino acid from the N terminal end of the peptide. They cannot hydrolyze the linkages of di-peptides or if the N terminal amino acid is proline. Prolidases are enzymes that hydrolyze linkages involving proline.

Thus by the concerted action of all the above enzymes, proteins are broken down to di and tri-peptides. Di and tri peptidases present in the intestinal mucosal cells or inside the absorptive cells cleave them to amino acids.

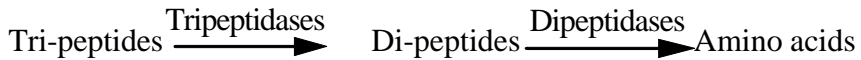

2.2.5 Absorption of amino acids

Amino acids and small peptides that are absorbed will reach liver through the portal circulation.

Naturally occurring L-amino acids are absorbed actively, while D-amino acids are absorbed passively. Absorption of amino acids are similar to those of carbohydrates and they need a carrier and sodium ions.

Amino acids are absorbed via glutathione cycle. The steps involved in glutathione cycle are

- a. Glutathione combines with amino acids to form γ -glutamyl amino acid and cysteinyl glycine.
- b. γ -glutamyl amino acid is transported and hydrolyzed to oxo proline and L.amino acid, which is absorbed.
- c. Cysteinyl glycine is cleaved to cysteine and glycine.
- d. Oxoproline is converted back to glutamate.
- e. Glutamate, cysteine and glycine combine together and form glutathione.

2.2.6 Factors affecting absorption

1. Dinitro phenol or cyanide decreases the absorption of amino acids.
2. Amino acids compete with one another for absorption. High concentrations of one amino acid reduces the absorption of the others.
3. Glutathione is needed to absorb the amino acids via glutathione cycle.

2.3 Digestion of Lipids

As all the enzymes involved in digestion are water soluble, lipids pose a special problem due to their insoluble nature. The problem of fat digestion is solved by emulsification of fats (i.e). breaking of large fat particles to small particles such that there is an increase in the surface area, which facilitates the interaction of fats with the fat hydrolyzing enzyme lipase.

Dietary sources of fat are from animal as well as vegetable origin. Animal sources include dairy products like milk, butter, ghee, meat, pork, eggs and fish. Vegetable sources include various cooking oils. Vegetables sources are superior to animal sources because of the presence of the various polyunsaturated fatty acids.

2.3.1 Digestion in mouth

Recently, a lingual lipase has been detected in mouth. Its optimum pH is 4 to 4.5. It acts on the food in the stomach, where it resides for some time. Lingual lipase is best suited to act on milk.

2.3.2 Digestion in stomach

Gastric lipase acts on triglycerides to some extent only because,
(a) no emulsification of fats takes place in the stomach.

- (b) the quantity of enzyme present is very low.
- (c) it has an optimum activity at pH 7.8

Satiety value

Fats delay the rate of emptying of stomach, by inhibiting the gastric motility via the hormone enterogastrone. Thus they have a high satiety value (fillingness of the stomach).

2.3.3 Digestion in duodenum and small intestine

The digestion of fats takes place mainly in the duodenum and small intestine because of the presence of powerful enzyme lipase in the pancreatic juice and emulsification of fats by the bile salts.

Pancreatic lipase is called as steapsin and it acts on the triglycerides present in the diet. It has an optimum pH at the alkaline range.

The action of lipase on triglycerides occurs by the following steps.

- (a) Conversion of triglyceride to α , β diglyceride by removal of the terminal fatty acid.
- (b) Removal of α fatty acid to produce β monoglyceride.
- (c) β monoglycerides are not acted upon by lipases, so they are isomerized to α monoglyceride.
- (d) Complete hydrolysis of α monoglyceride to free fatty acid and glycerol.

The other enzymes present in pancreatic juice are phospholipases and cholesterol esterase.

There are four different phospholipases that can cleave phospholipids to glycerol, free fatty acids, phosphoric acid and the base. They are phospholipase A₁, phospholipase A₂, phospholipase C and phospholipase D. The site of actions of phospholipases are as follows.

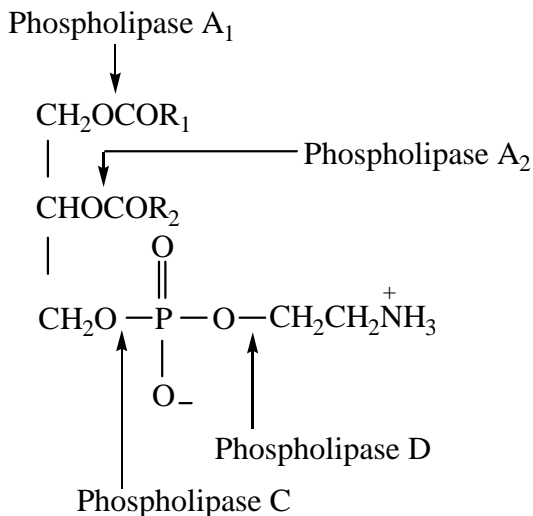

The action of cholesterol esterase is,

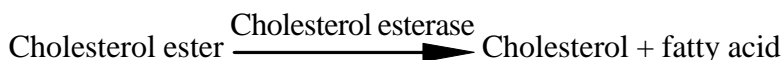

2.3.4 Absorption of fats

1. Free fatty acids are absorbed by the absorptive cells of the intestinal walls by simple diffusion. As the entering fatty acids are rapidly converted to triglycerides, the above process is speeded up.
2. A part of glycerol and short chain fatty acids are directly absorbed by the portal circulation and taken to the liver.
3. Glycerol and fatty acids that enter to the intestinal epithelial cells are converted to triglycerides and in the lacteals, they are covered with a layer of hydrophilic phospholipids, cholesterol, cholesterol

esters and an apoprotein apo B. After being packaged to a more hydrophilic soluble form, they enter into the lymphatic circulation and finally enters the systemic circulation via the thoracic duct.

2.3.6 Factors affecting absorption

1. Short chain fatty acids are absorbed at a faster rate than long chain fatty acids. They also enhance the absorption of long chain fatty acids.
2. Plant sterols like stigmasterol and sitosterol inhibit cholesterol absorption.
3. Bile salts enhance the digestion of fats. Absence of bile in jaundice reduces the digestion of fats.
4. Absorption of cholesterol is facilitated by unsaturated fatty acids and bile salts.

2.4 Digestion of Nucleic acids

2.4.1 Digestion in mouth and stomach

There are no enzymes to digest nucleic acids in the mouth.

The highly acidic medium in the stomach destabilizes the nucleoprotein structure and the proteolytic enzymes split them to nucleic acids and proteins.

2.4.2 Digestion in duodenum

Pancreatic juice contains two enzymes ribonuclease and deoxyribonuclease that can hydrolyze the nucleic acids to mononucleotides.

Depending upon the site of action, nucleases can be either endonuclease that attacks the interior linkages and exonuclease that attacks the terminal linkages.

The intestinal juice (succus entericus) contains the following two enzymes that digest nucleic acids.

- a. Nucleotidases that hydrolyze nucleotides to nucleosides and phosphoric acid.
- b. Nucleosidases that hydrolyzes the nucleosides to their respective sugars and bases.

2.4.3 Gastro Intestinal Hormones

There are three major gastro intestinal hormones secreted by the gut. They are gastrin, secretin and cholecystokinin. All of them are polypeptides synthesized by the mucosal endocrine cells of the stomach and small intestine.

Gastrin is produced by the mucosal cells of the pyloric region of the stomach and is the most effective activator of gastric acid secretion. Two gastrins, Gastrin I and Gastrin II have been identified. Gastrin I has 17 amino acids and Gastrin II has 14 amino acids. Gastrin secretion increases with age, vagal stimulation, acetyl choline and intake of foods rich in proteins and amino acids particularly glycine. The terminal four amino acids of gastrin are responsible for its hormonal action.

Secretin is a polypeptide with 27 amino acids of which 14 amino acids are identical to that of glucagon. It is formed in the duodenal mucosal cells. The secretion is stimulated by HCl and it increases the secretion of electrolytes and fluid components of pancreatic juice. It is one of the factors that increase the secretion of bile by the liver. It can act like glucagon by increasing the cardiac output and lipolysis.

Cholecystokinin and Pancreozymin are two hormones that stimulate the secretion of pancreatic juice. Pancreozymin also stimulates the pancreas to secrete insulin and glucagons. Due to this action of

pancreozymin, insulin secretion is higher when glucose is given orally than intravenously. Out of the 33 amino acids present in the pancreozymin, the eight C terminal amino acids are biologically active.

Cholecystokinin causes contraction of the gall bladder and discharge the bile into the duodenum. Discharge of bile is also stimulated by secretin and bile salts.

Other gut hormones

Hepatocrinin stimulates the formation of bile, which is low in bile salts. Motilin increases gastric motility. Enterogastrone and gastric inhibitory polypeptide inhibit gastric acid secretion and gastric motility. Enterocrinin stimulates the secretion of enzymes by the intestinal mucosa. Chymodenin stimulates the secretion of chymotrypsin from pancreas.

Exercises

I. Choose the correct answer from the four alternatives

- a. The enzyme which is not of pancreatic origin is
i) trypsin ii) amylase iii) sucrase iv) chromotrypsin

- b. There are enzymes in the stomach to digest
i) proteins ii) minerals iii) vitamins iv) none of the above

- c. Pepsin is activated by
i) autocatalytically ii) rennin iii) HCl iv) HCl & autocatalytically

- d. Satiety value is high for
i) carbohydrates ii) proteins iii) fats iv) vitamins

- e. D amino acids are absorbed by
 i) passive diffusion ii) active transport
 iii) both of them iv) none of the above
- f. Which ions are needed for glucose transporter?
 i) Na⁺ ii) K⁺ iii) Mg²⁺ iv) Ca²⁺
- g. Which one is not a pancreatic enzyme ?
 i) trypsin ii) chymotrypsin iii) pepsin iv) elastases

II. Fill up the blanks

- Pancreatic lipase is also called as _____.
- Cholecystinin and _____ are two hormones that stimulate pancreatic juice secretion.
- _____ or cyanide decreases the absorption of amino acids.
- Secretin is a polypeptide with _____ amino acids.
- The enzymes that digest nucleic acids are present in the _____.

III. Say true or False

- Lactase is an enzyme present in the pancreatic juice.
- Chloride ions are needed for the action of amylase.
- Absorption of amino acids is carried out by amino acid transporters.
- Dipeptides cannot be absorbed by the mucosal cells of the intestine.
- Gastrin is an enzyme involved in protein digestion.
- Fats are hydrolysed by acidic pH in the stomach.

IV. Match the following

- | | | | |
|----|---------------------|---|------------------------------|
| 1. | Bile salts | - | Endopeptidase |
| 2. | Chymotrypsin | - | Exopeptidase |
| 3. | Carboxy peptidase A | - | GI tract hormone |
| 4. | Lysolecithin | - | Emulsification |
| 5. | Secretin | - | Phospholipase A ₂ |

V. Give one word answer

1. Name the tripeptides involved in the absorption of amino acids.
2. Give the reaction by which maltose is converted to glucose?
3. Name the enzymes in the stomach to digest proteins.
4. What is the action of HCl on nucleoproteins?.
5. Name the hormone that influences the absorption of carbohydrates.
6. What is the enzyme that cleaves the branch points in starch?
7. Why cellulose cannot be digested by humans?
8. List any two GI hormones.

VI. Answer the following briefly

1. Give an account on digestion of proteins.
2. Briefly a note on GI tract hormones.
3. Discuss the factors that affect carbohydrates and lipid absorption.
4. How are fats digested?
5. How are carbohydrates absorbed from the diet?

CHAPTER III

Carbohydrate Metabolism

Introduction

Glucose is the major form of sugar moiety present in blood and other body fluids. The digestion of food carbohydrates, such as starch, sucrose, and lactose produces the monosaccharides glucose, fructose and galactose, which pass into the blood stream. The study of synthesis (Anabolism) and degradation (Catabolism) of biomolecules is biochemically termed as metabolism.

Anabolism + Catabolism = Metabolism
(Synthesis) (Degradation)

Since glucose is the most important carbohydrate existing in physiological amounts in the body and is easily absorbed from the diet, the metabolism of carbohydrate resolves itself to the study of the metabolism of glucose and its main derivatives. The monosaccharides galactose and fructose are converted to glucose in the liver. All the monosaccharides are completely absorbed in the small intestine.

The glucose in the circulating blood and tissue fluids is drawn upon by all the cells of the body and used for the production of energy. Normally carbohydrate metabolism supplies more than half of the energy requirements of the body. In fact the brain largely depends upon carbohydrate metabolism as a source of energy and quickly ceases to function properly when the blood glucose level falls much below normal.

3.1 Carbohydrate as a source of energy

The major function of carbohydrate in metabolism is to serve as fuel and get oxidised to provide energy for other metabolic processes. The metabolic intermediates are used for various biosynthetic reactions. For this purpose, carbohydrate is utilized by the cells mainly in the form of glucose. A major part of dietary glucose is converted to glycogen for storage in liver. Glucose is degraded in the cell by way of a series of phosphorylated intermediates mainly via two metabolic pathways.

1. Glycolysis
2. Tricarboxylic acid cycle

3.2 Glycolysis

Oxidation of glucose to pyruvate is called glycolysis. It was first described by Embden-Meyerhof and Parnas. Hence it is also called as Embden-Meyerhof pathway.

Glycolysis occurs virtually in all tissues. Erythrocytes and nervous tissues derive the energy mainly from glycolysis. This pathway is unique in the sense that it can proceed in both aerobic (presence of O_2) and anaerobic (absence of O_2) conditions.

All the enzymes of glycolysis are found in the extra mitochondrial soluble fraction of the cell, the cytosol.

3.2.1 Reactions of glycolytic pathway

Series of reactions of glycolytic pathway which degrades glucose to pyruvate are represented below. The sequence of reactions occurring in glycolysis may be considered under four stages.

Stage I

This is a *preparatory phase*. Before the glucose molecule can be split, the rather asymmetric glucose molecule is converted to almost symmetrical form, fructose 1,6-diphosphate by donation of two phosphate groups from ATP.

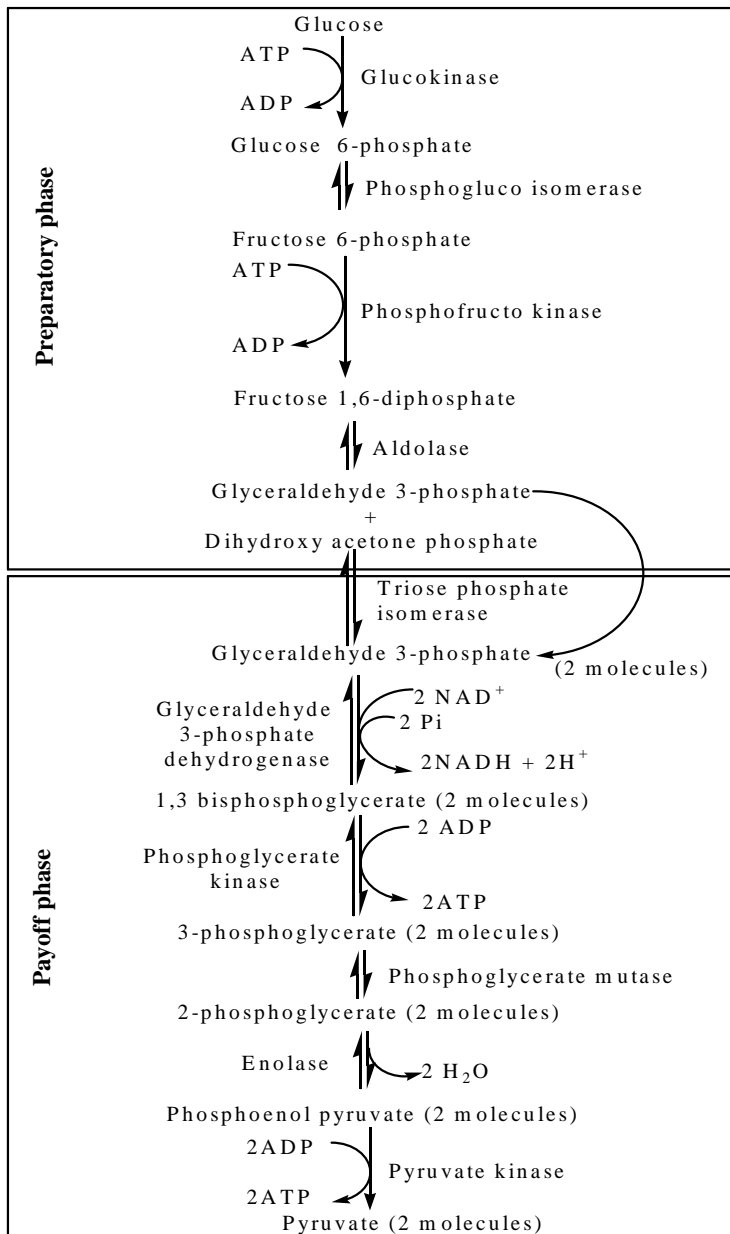
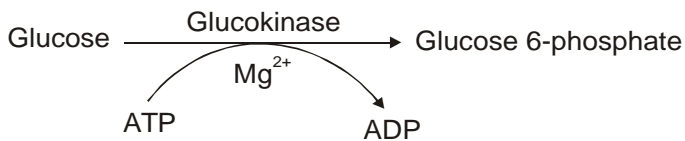

Fig.3.1 The glycolytic pathway

1. Uptake of glucose by cells and its phosphorylation

Glucose is freely permeable to liver cells, intestinal mucosa and kidney tubules where glucose is taken up by 'active' transport. In other tissues insulin facilitates the uptake of glucose. Glucose is phosphorylated to form glucose 6-phosphate. The enzyme involved in this reaction is glucokinase. This reaction is irreversible.



2. Conversion of glucose 6-phosphate to fructose 6-phosphate

Glucose 6-phosphate is converted to fructose 6-phosphate by the enzyme phosphoglucose isomerase.



3. Conversion of fructose 6-phosphate to fructose 1,6-diphosphate

Fructose 6-phosphate is phosphorylated irreversibly at 1 position catalyzed by the enzyme phosphofructokinase to produce fructose 1,6-diphosphate.

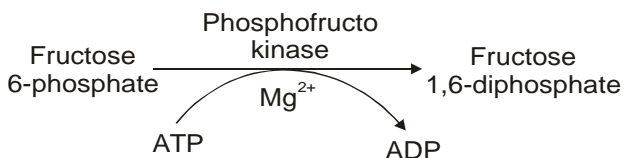

Stage II

1. Actual splitting of fructose 1,6 diphosphate

Fructose 1,6 diphosphate is split by the enzyme aldolase into two molecules of triose phosphates, an aldotriose-glyceraldehyde 3-phosphate and one ketotriose - dihydroxy acetone phosphate. The reaction is reversible. There is neither expenditure of energy nor formation of ATP.

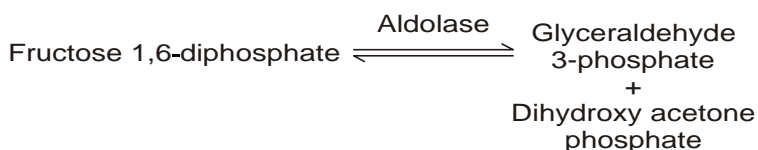

2. Interconversion of triose phosphates

Both triose phosphates are interconvertible

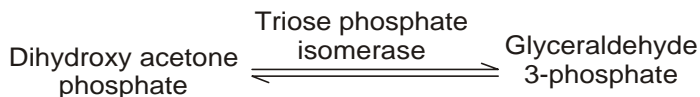

Stage III

It is the energy yielding stage. Reactions of this type in which an aldehyde group is oxidised to an acid are accompanied by liberation of large amounts of potentially useful energy.

1. Oxidation of glyceraldehyde 3-phosphate to 1,3-bisphosphoglycerate

Glycolysis proceeds by the oxidation of glyceraldehyde 3-phosphate to form 1,3-bisphosphoglycerate. The reaction is catalyzed by the enzyme glyceraldehyde 3-phosphate dehydrogenase

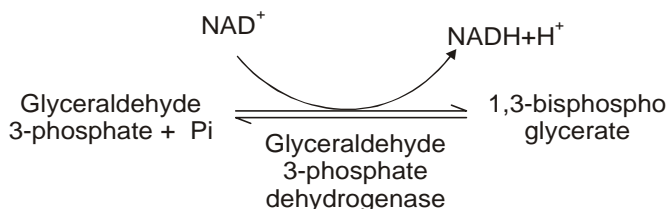

2. Conversion of 1,3-bisphosphoglycerate to 3-phosphoglycerate

The reaction is catalyzed by the enzyme phosphoglycerate kinase. The high energy phosphate bond at position - 1 is transferred to ADP to form ATP molecule.

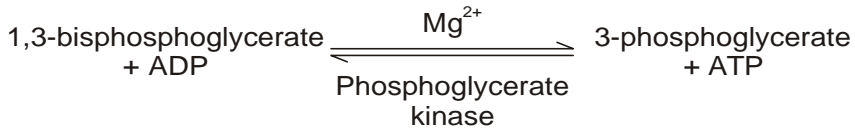

Stage IV

It is the recovery of the phosphate group from 3-phosphoglycerate. The two molecules of 3-phosphoglycerate, the end-product of the previous stage, still retains the phosphate group, originally derived from ATP in Stage I.

1. Conversion of 3-phosphoglycerate to 2-phosphoglycerate.

3-phosphoglycerate formed by the above reaction is converted to 2-phosphoglycerate, catalyzed by the enzyme phosphoglycerate mutase.

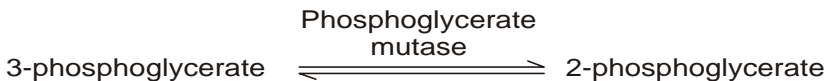

2. Conversion of 2-phosphoglycerate to phosphoenol pyruvate

The reaction is catalyzed by the enzyme enolase, the enzyme requires the presence of either Mg^{2+} or Mn^{2+} ions for activity.

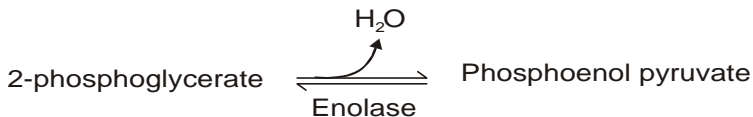

3. Conversion of phosphoenol pyruvate to pyruvate

Phosphoenol pyruvate is converted to pyruvate, the reaction is catalysed by the enzyme pyruvate kinase. The high energy phosphate group of phosphoenol pyruvate is directly transferred to ADP, producing ATP. The reaction is irreversible.

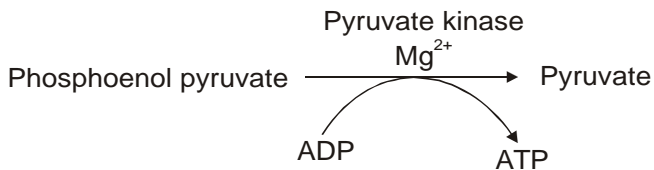

3.2.2 Summary of glycolysis

During glycolysis NAD^+ is reduced to NADH . At the same time, glyceraldehyde 3-phosphate is oxidized to 1,3-bisphosphoglycerate. To conserve the coenzyme NAD^+ , NADH must be reoxidized. Under anaerobic conditions this is done when pyruvic acid is converted to lactic acid. In the presence of oxygen, NADH , can be oxidized to NAD^+ with the help of the respiratory enzymes.

3.2.3 Energy yield per glucose molecule oxidation

During glycolysis ATP molecules are used and formed in the following reactions (aerobic phase).

Table 3.1

Reactions Catalyzed	ATP used	ATP formed
Stage I		
1. Glucokinase (for phosphorylation)	1	
2. Phosphofructokinase I (for phosphorylation)	1	
Stage II		
3. Glyceraldehyde 3-phosphate dehydrogenase (oxidation of 2 NADH in respiratory chain)		6
4. Phosphoglycerate kinase (substrate level phosphorylation)		2
Stage IV		
5. Pyruvate kinase (substrate level phosphorylation)		2
Total	2	10

Net gain = 8 ATP

Anaerobic phase

In the absence of O_2 , reoxidation of NADH at glyceraldehyde 3-phosphate dehydrogenase stage cannot take place in respiratory chain. But the cells have limited coenzyme. Hence to continue the glycolysis **NADH must be reoxidized to NAD^+** . This is achieved by reoxidation of NADH by conversion of pyruvate to lactate (without producing ATP).

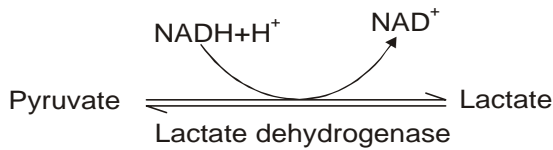

It is to be noted that in the reaction catalyzed by glyceraldehyde 3-phosphate dehydrogenase, therefore, no ATP is produced.

In the anaerobic phase oxidation of one glucose molecule produces $4 - 2 = 2$ ATP.

3.3 Tricarboxylic acid cycle (TCA cycle)

This cycle is the aerobic phase of carbohydrate metabolism and follows the anaerobic pathway from the stage of pyruvate and is called as citric acid cycle or TCA cycle. The name citric acid cycle stems from citric acid which is formed in the first step of this cycle. This cycle is also named "Kerbs cycle" after H.A. Krebs, an English biochemist who worked on it.

Under aerobic conditions, pyruvate is oxidatively decarboxylated to acetyl coenzyme A (active acetate) before entering the citric acid cycle. This occurs in the mitochondrial matrix and forms a link between glycolysis and TCA cycle.

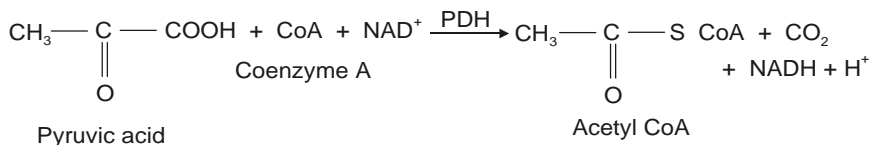

PDH-pyruvate dehydrogenase

This reaction is catalysed by the multienzyme complex known as pyruvate dehydrogenase complex.

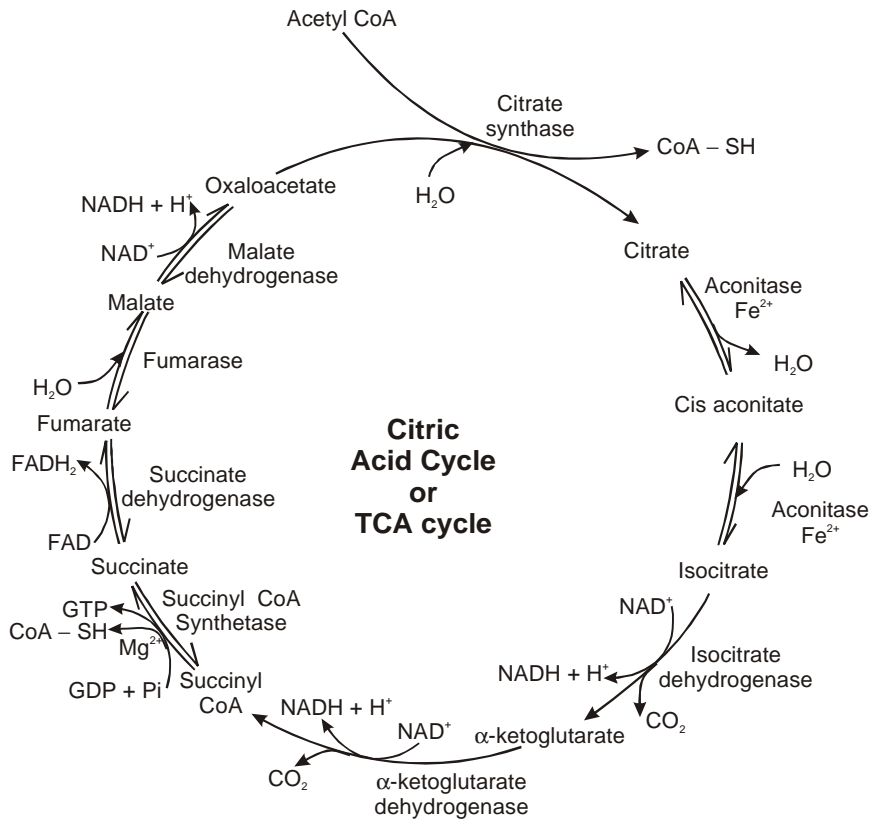

Fig.3.2 Krebs Cycle

3.3.1 Reactions of the citric acid cycle

There are eight steps in the cycle and the reactions are as follows.

1. Formation of citrate

The first reaction of the cycle is the condensation of acetyl CoA with oxaloacetate to form citrate, catalyzed by citrate synthase. This is an irreversible reaction.

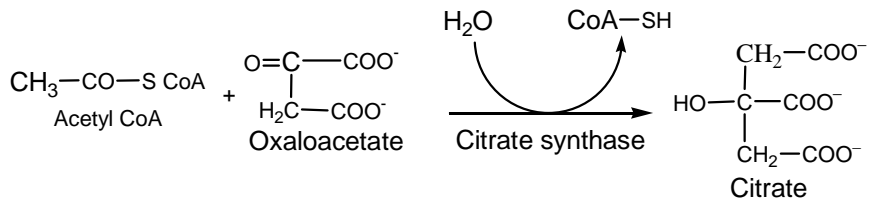

2. Formation of isocitrate via cis aconitate

The enzyme aconitase catalyzes the reversible transformation of citrate to isocitrate, through the intermediary formation of cis aconitate.

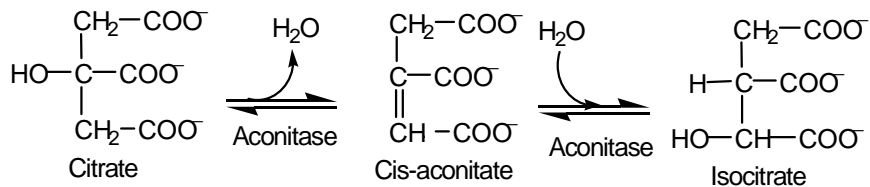

3. Oxidation of isocitrate to α -ketoglutarate and CO_2

In the next step, isocitrate dehydrogenase catalyzes oxidative decarboxylation of isocitrate to form α -ketoglutarate.

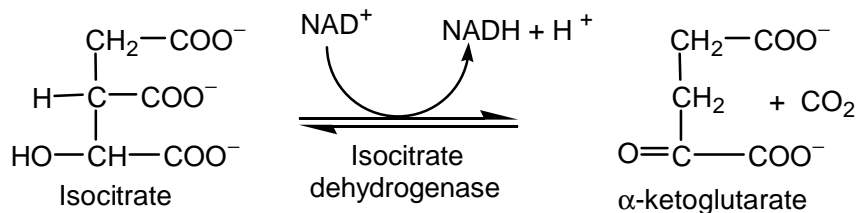

4. Oxidation of α -keto glutarate to succinyl CoA and CO_2

The next step is another oxidative decarboxylation, in which α -ketoglutarate is converted to succinyl CoA and CO_2 by the action of the α -ketoglutarate dehydrogenase complex. The reaction is irreversible.

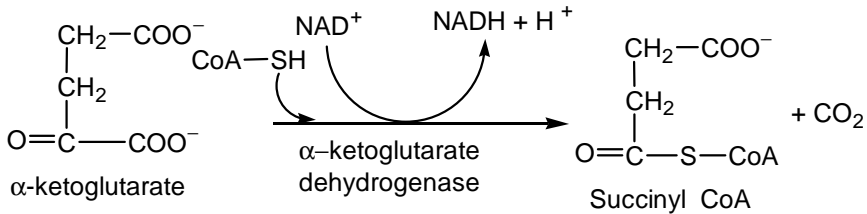

5. Conversion of succinyl CoA to succinate

The product of the preceding step, succinyl CoA is converted to succinate to continue the cycle. GTP is formed in this step (substrate level phosphorylation).

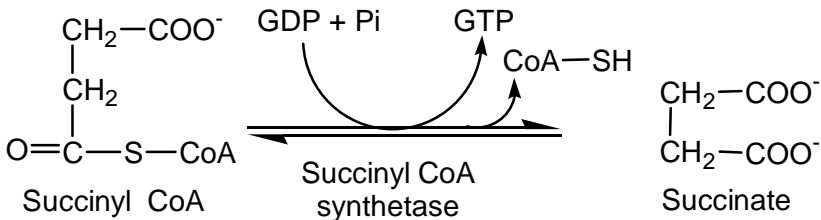

The enzyme that catalyzes this reversible reaction is called succinyl CoA synthetase or succinic thiokinase.

6. Oxidation of succinate to fumarate

The succinate formed from succinyl CoA is oxidized to fumarate by the enzyme succinate dehydrogenase

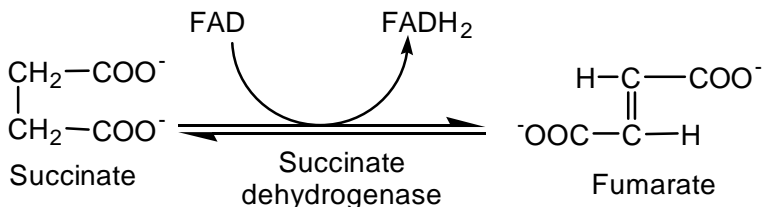

7. Hydration of fumarate to malate

The reversible hydration of fumarate to malate is catalyzed by fumarase.

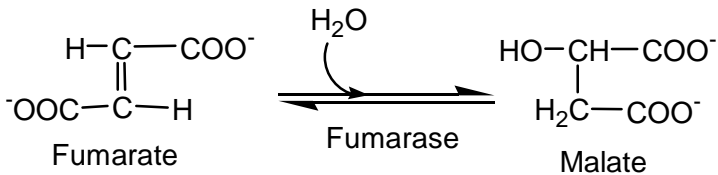

8. Oxidation of malate to oxaloacetate

The last reaction of the citric acid cycle is, NAD linked malate - dehydrogenase which catalyses the oxidation of malate to oxaloacetate.

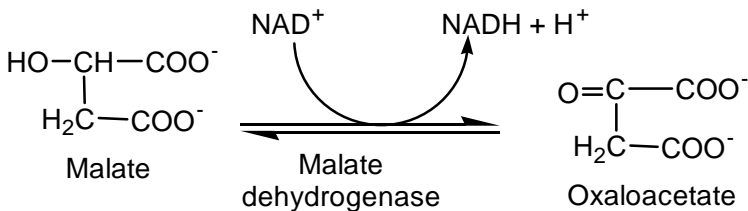

3.3.2 Energy yield from TCA cycle

If one molecule of the substrate is oxidized through NADH in the electron transport chain three molecules of ATP will be formed and through FADH_2 , two ATP molecules will be generated.

As one molecule of glucose gives rise to two molecules of pyruvate by glycolysis, intermediates of citric acid cycle also result as two molecules.

Table 3.2

Reactions	No.of ATP formed
1. 2 isocitrate \rightarrow 2 α -ketoglutarate (2 NADH + 2H ⁺) (2 \times 3)	6
2. 2 α -ketoglutarate \rightarrow 2 succinyl CoA (2 NADH + 2H ⁺) (2 \times 3)	6
3. 2 succinyl CoA \rightarrow 2 succinate (2 GTP = 2ATP)	2
4. 2 succinate \rightarrow 2 Fumarate (2 FADH ₂) (2 \times 2)	4
5. 2 malate \rightarrow 2 oxaloacetate (2 NADH + 2H ⁺) (2 \times 3)	6
Total No.of ATP formed	24

3.4 HMP shunt pathway

Although glycolysis and citric acid cycle are the common pathways by which animal tissues oxidise glucose to CO₂ and H₂O with the liberation of energy in the form of ATP, a number of alternative pathways are also discovered. The most important one is Hexose Monophosphate Shunt Pathway (HMP shunt). The pathway occurs in the extra mitochondrial soluble portion of the cells.

Unlike glycolysis and Krebs cycle which are primarily concerned with the generation of ATP, HMP shunt generates a different type of metabolic energy - the reducing power. Some of the electrons and hydrogen atoms of fuel molecules are conserved for biosynthetic purposes rather than ATP formation. This reducing power of cells is NADPH (reduced nicotinamide adenine dinucleotide phosphate).

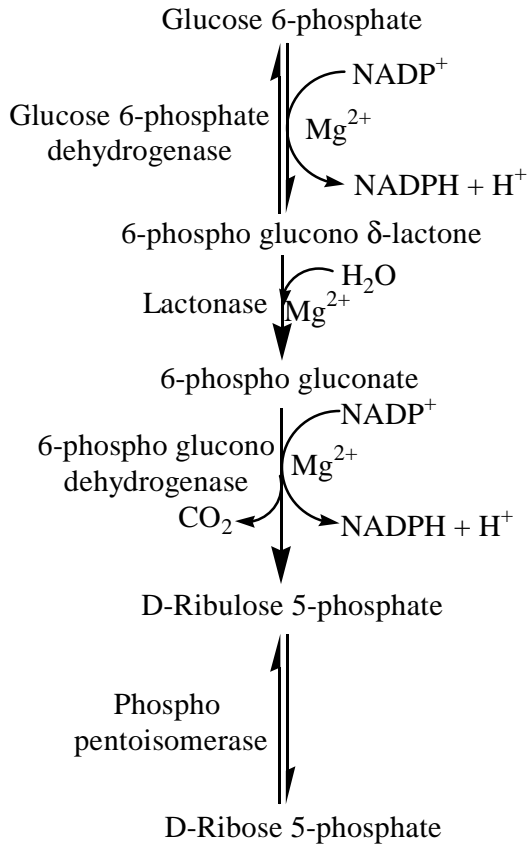

Fig. 3.3 Oxidative reactions of the hexose mono-phosphate pathway

The fundamental difference between NADPH and NADH (reduced nicotinamide adenine dinucleotide) is that NADH is oxidised by the respiratory chain to generate ATP whereas NADPH serves as a hydrogen and electron donor in reductive biosynthesis, for example in the biosynthesis of fatty acids and steroids.

The first reaction of the pentose phosphate pathway is the dehydrogenation of glucose 6-phosphate by glucose 6-phosphate dehydrogenase to form 6-phosphoglucono δ -lactone.

Step 1

Glucose 6-phosphate in the presence of NADP and the enzyme glucose 6-phosphate dehydrogenase, forms 6-phospho glucono- δ -lactone. The first molecule of NADPH is produced in this step.

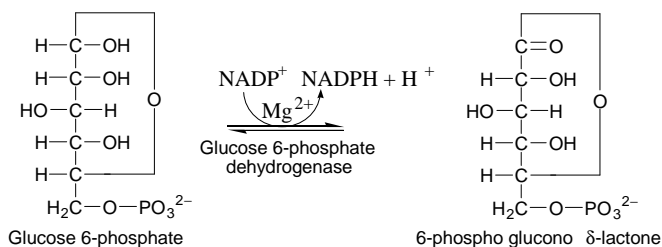

Step 2

The 6-phospho glucono δ -lactone is unstable and the ester spontaneously hydrolyses to 6-phosphogluconate. The enzyme that catalyses the reaction is lactonase

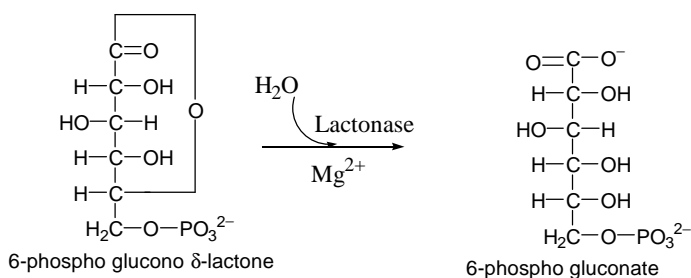

Step 3

6-phospho gluconate further undergoes dehydrogenation and decarboxylation by 6-phosphogluconate dehydrogenase to form the ketopentose, D-ribulose 5-phosphate. This reaction generates the second molecule of NADPH.

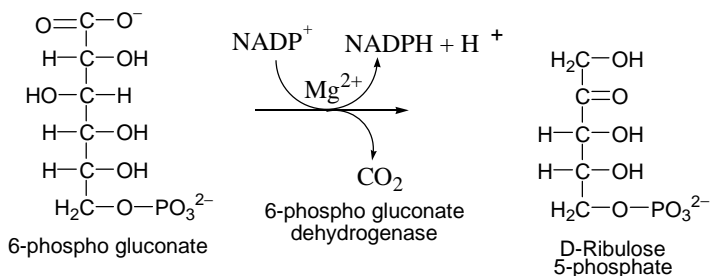

Step 4

The enzyme phosphopentose isomerase converts ribulose 5-phosphate to its aldose isomer, D-ribose 5-phosphate.

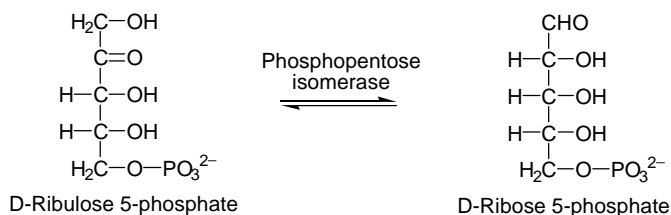

In some tissues, the hexose phosphate pathway ends at this point, and its overall equation is

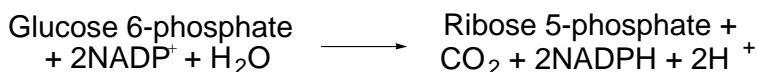

The net result is the production of NADPH, a reductant for biosynthetic reactions, and ribose 5-phosphate, a precursor for nucleotide synthesis.

3.5 Glycogen

Glycogen is the major storage form of carbohydrate in animals and corresponds to starch in plants. It occurs mainly in liver.

3.5.1 Glycogen biosynthesis

The process of biosynthesis of glycogen from glucose is known as glycogenesis. This occurs in all the tissues of the body but the major sites are liver and muscles. A considerable amount is synthesised in kidney also.

Glycogenesis is a very essential process since the excess of glucose is converted and stored up as glycogen which could be utilised at the time of requirement. In the absence of this process the tissues are exposed to excess of glucose immediately after a meal and they are starved of it at other times. The following are the various reactions of glycogenesis.

Step 1

Glucose is phosphorylated to glucose 6-phosphate, a reaction that is common to the first reaction in the pathway of glycolysis from glucose. This reaction is catalysed by hexokinase in muscle and glucokinase in liver in the presence of ATP.

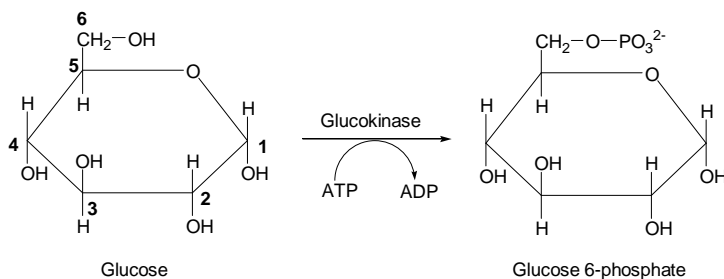

Step 2

Glucose 6-phosphate is then reversibly converted to glucose 1-phosphate in a reaction catalysed by enzyme phosphogluco mutase. This process requires Mg^{2+} and a small amount of glucose 1,6-diphosphate as coenzyme.

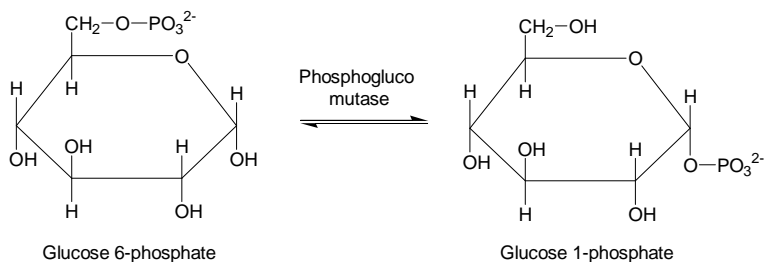

Step 3

The glucose 1-phosphate is then activated by the energy produced by the hydrolysis of uridine triphosphate (UTP) in the presence of uridine diphosphate glucose pyrophosphorylase. This is a key reaction in glycogen biosynthesis.

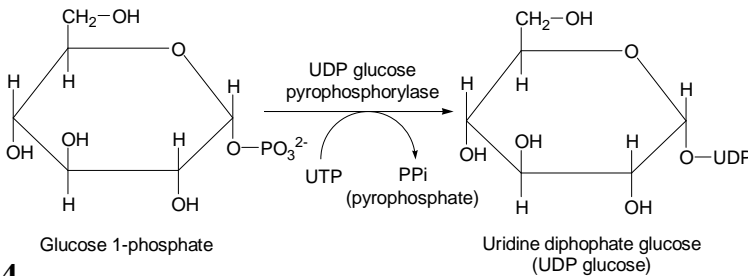

Step 4

UDP-glucose is the immediate donor of glucose residues in the reaction catalyzed by glycogen synthase, which promotes the transfer of the glucose residue from UDP-glucose to a nonreducing end of a branched glycogen chain.

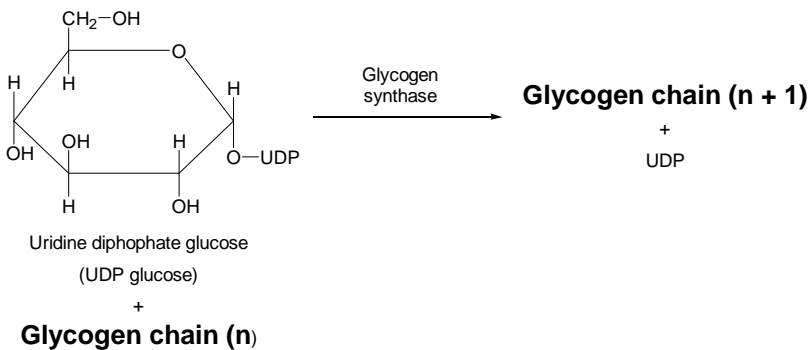

Step 5

When the chain has become long with more than 8 glucose units, a second enzyme, namely branching enzyme amylo 1-4 to 1-6 transglycosylase acts on the glycogen and helps in joining of 1,4 glycogen chain with a similar neighbouring chain to form α 1-6 linkage, thus forming

a branching point in the molecule. Glycogen thus formed may be stored in liver, muscles and tissues.

3.5.2 Degradation of glycogen (Glycogenolysis)

When the blood sugar level falls (Hypoglycemia), glycogen stored in the tissues specially glycogen of liver and muscles may be broken down and this process of breakdown of glycogen is called glycogenolysis.

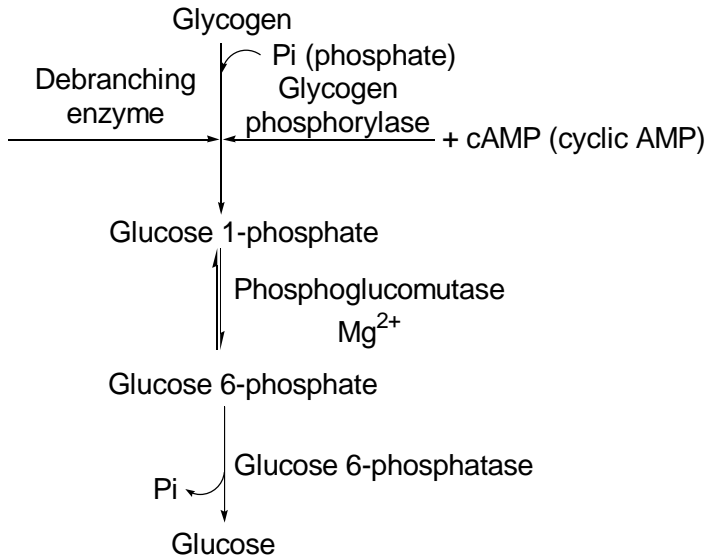

Fig.3.4 Glycogenolysis

The following are the various steps of glycogenolysis.

Step 1

The first step in the breakdown of glycogen is catalyzed by two enzymes which act independently.

The first enzyme, namely glycogen phosphorylase with inorganic phosphate catalyses the cleavage of a terminal α 1-4 bond of glycogen to produce glycogen with one molecule less and a molecule of glucose 1-phosphate. The enzyme glycogen phosphorylase cannot cleave α 1-6 linkage. This is carried out by another enzyme called the debranching enzyme (α 1-6 glucosidase) which hydrolyses these bonds and thus make more α 1-4 linkage accessible to the action of glycogen phosphorylase.

The combined action of glycogen phosphorylase and the debranching enzyme converts glycogen to glucose 1-phosphate.

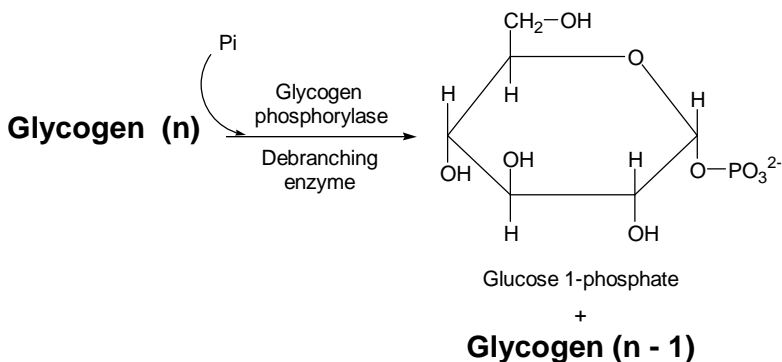

Step 2

The glucose 1-phosphate is then reversibly converted to glucose 6-phosphate by the action of the enzyme phosphoglucomutase

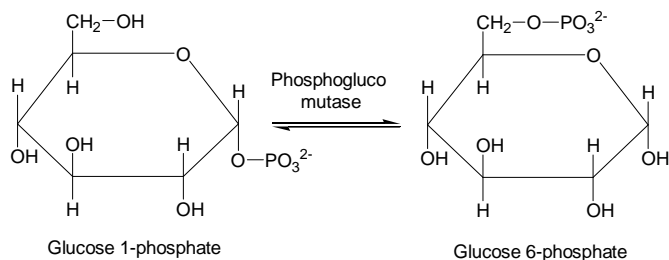

Step 3

The next reaction namely the conversion of glucose 6-phosphate to glucose takes place in the liver and kidney by the action of the enzyme glucose 6-phosphatase.

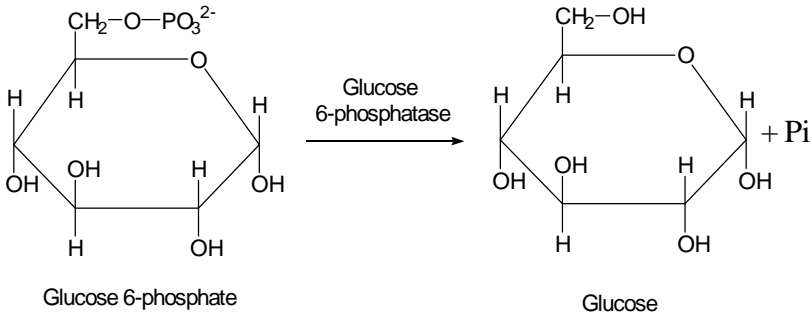

Glucose 6-phosphatase removes phosphate group from glucose 6-phosphate enabling the free glucose to diffuse from the cell into the extra cellular spaces including blood. This reaction does not occur in the muscles because muscles lack the enzyme glucose 6-phosphatase.

3.5.3 Gluconeogenesis

The synthesis of glucose from non-carbohydrate precursors is known as gluconeogenesis. The major site of gluconeogenesis is liver. It usually occurs when the carbohydrate in the diet is insufficient to meet the demand in the body, with the intake of protein rich diet and at the time of starvation, when tissue proteins are broken down to amino acids.

3.5.3.1 Gluconeogenesis and glycolysis

Gluconeogenesis and glycolysis are opposing metabolic pathways and share a number of enzymes. In glycolysis, glucose is converted to pyruvate and in gluconeogenesis pyruvate is converted to glucose. However gluconeogenesis is not exact reversal of glycolysis.

There are three essentially irreversible steps in glycolysis which are

1. $\text{Glucose} + \text{ATP} \xrightarrow{\text{Glucokinase}} \text{Glucose 6-phosphate} + \text{ADP}$
2. $\text{Fructose 6-phosphate} + \text{ATP} \xrightarrow{\text{Phosphofructokinase}} \text{Fructose 1,6-diphosphate} + \text{ADP}$
3. $\text{Phosphoenolpyruvate} + \text{ADP} \xrightarrow{\text{Pyruvate kinase}} \text{Pyruvate} + \text{ATP}$

In gluconeogenesis these three reactions are bypassed or substituted by the following new ones.

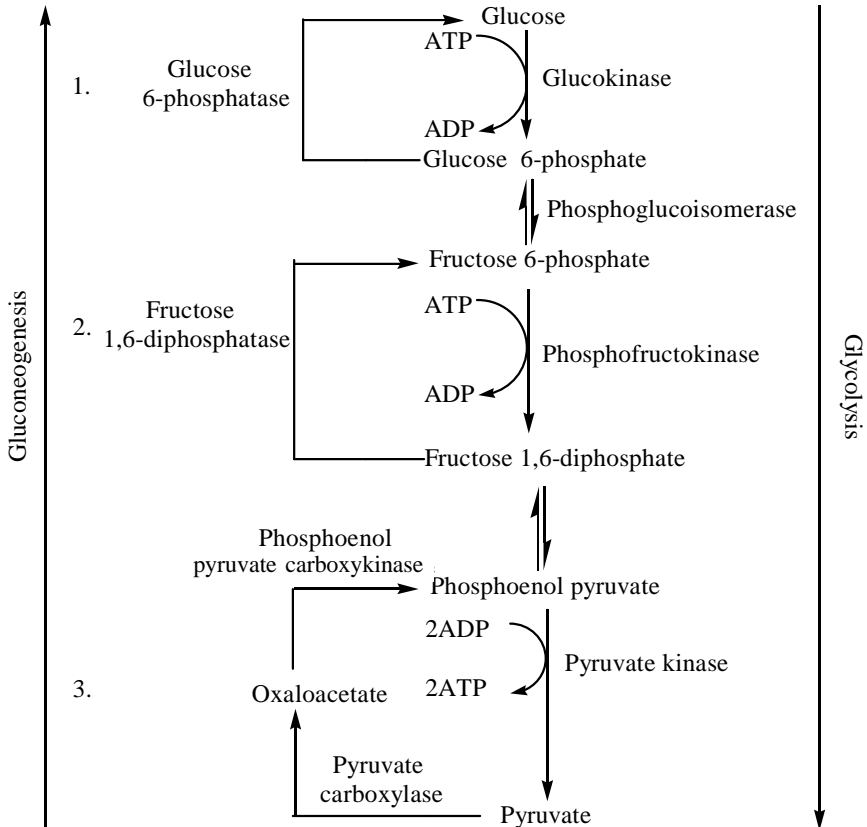

Fig. 3.5 Gluconeogenesis and Glycolysis

3.5.3.3 Gluconeogenesis of amino acids

Amino acids which could be converted to glucose are called glucogenic amino acids. Most of the glucogenic amino acids are converted to the intermediates of citric acid cycle either by transamination or deamination.

3.5.3.4 Gluconeogenesis of Propionate

Propionate is a major source of glucose in ruminants, and enters the main gluconeogenic pathway via the citric acid cycle after conversion to succinyl CoA.

3.5.3.5 Gluconeogenesis of Glycerol

At the time of starvation glycerol can also undergo gluconeogenesis. When the triglycerides are hydrolysed in the adipose tissue, glycerol is released. Further metabolism of glycerol does not take place in the adipose tissue because of the lack of glycerol kinase necessary to phosphorylate it. Instead, glycerol passes to the liver where it is phosphorylated to glycerol 3-phosphate by the enzyme glycerol kinase.

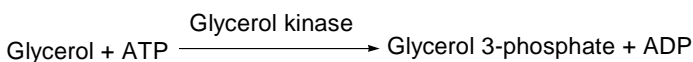

This pathway connects the triose phosphate stage of glycolysis, because glycerol 3-phosphate is oxidized to dihydroxy acetone phosphate in the presence of NAD^+ and glycerol 3-phosphate dehydrogenase.

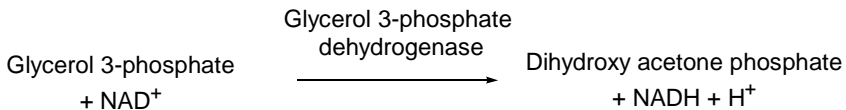

This dihydroxy acetone phosphate enters gluconeogenesis pathway and gets converted to glucose. Liver and kidney are able to convert glycerol to blood glucose by making use of the above enzymes.

3.5.3.6 Gluconeogenesis of lactic acid (Cori cycle)

The liver and skeletal muscles exhibit a special metabolic cooperation as far as carbohydrates are concerned by the way of a cycle of conversions known as Cori cycle.

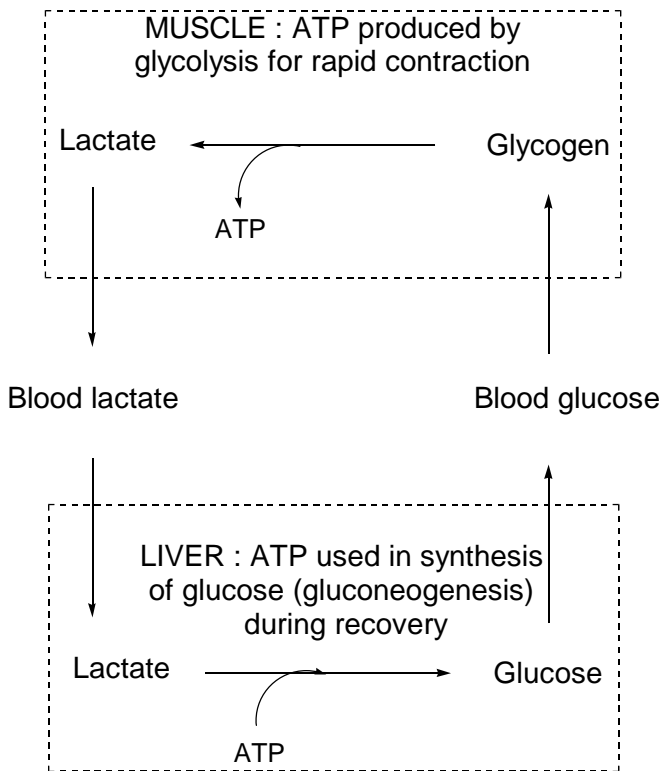

Fig. 3.6 Cori cycle

In this cycle liver glycogen may be converted into muscle glycogen and vice versa and the major raw material of this cycle is lactate produced by the active skeletal muscles.

At the time of heavy muscular work or strenuous exercise, O_2 supply is inadequate in active muscles but the muscles keep contracting to the maximum. Hence, glycogen stored up in the muscle is converted into

lactic acid by glycogenolysis followed by anaerobic glycolysis and thus lactate gets accumulated in the muscle. Muscle tissue lacks the enzyme glucose 6-phosphatase hence it is incapable of synthesizing glucose from lactic acid and the conversion take place only in the liver.

Lactate diffuses out of the muscle and enters the liver through blood. In the liver lactate is oxidised to pyruvate which undergoes the process of gluconeogenesis resulting in the resynthesis of glucose. The glycogen may be once again converted to glucose (glycogenolysis) and may be recycled to the muscle through the blood. The process of gluconeogenesis completes the cycle by converting glucose once again to muscle glycogen.

3.6 Diabetes Mellitus

Diabetes mellitus is an important disorder of carbohydrate metabolism. However, fat and protein metabolism are also affected in diabetic condition. Diabetes means excretion of excessive volume of urine and mellitus means sweet. So the word diabetes mellitus refers to chronic excretion of large volume of urine containing glucose.

Diabetes mellitus, caused by a deficiency in the secretion or action of insulin, is a relatively common disease. Insulin is an endocrine hormone which is secreted by β -cells of islets of Langerhans of pancreas. The abnormality in glucose metabolism is indicative of diabetes or a tendency towards the condition. Diabetes mellitus is really a group of diseases in which the regulatory activity of insulin is defective.

There are two major clinical classes of the disease :

1. Type-I or insulin dependent diabetes mellitus (IDDM)

The disease begins early in the life and quickly becomes severe.

2. Type - II or non-insulin dependent diabetes mellitus (NIDDM)

The disease is slow to develop, milder and often goes unrecognized.

Type one requires insulin therapy and careful, life long control of the balance between glucose intake and insulin dose. The decreased or defective production of insulin is characterised by the following symptoms.

1. Decreased permeability of the cell membrane for glucose resulting in the accumulation of glucose in the blood. This condition is known as hyperglycemia. Glucose concentration increases as high as 500 mg/100 ml of blood.
2. **Polyuria:** This means excretion of increased quantity of urine. This is to excrete the additional quantity of glucose in urine (glucosuria).
3. **Polydipsia:** The excessive thirst which leads to increased consumption of water. This condition is known as polydipsia. This is to replace the volume of water excreted due to polyuria.
4. **Polyphagia:** Excessive appetite leads to polyphagia and increased intake of food. This is to replace the lost nourishment. The diabetic has voracious appetite, but inspite of over eating, they lose weight and become lean and emaciated.
5. As glucose is not enough for energy production, increased mobilisation of fat from adipose tissue occurs. But the metabolism of fat is incomplete resulting in the production of large amounts of the intermediary products of fat metabolism namely ketone bodies (eg. Acetoacetate and β -hydroxybutarate). This condition is known as 'ketosis' and excess ketone bodies cause severe acidosis, ultimately resulting in 'coma'.
6. Deposition of lipids in the walls of the blood vessels resulting "atherosclerosis".

Biochemical measurements on the blood and urine are essential in the diagnosis and treatment of diabetes, which causes profound changes

in metabolism. A sensitive diagnostic criterion is provided by the glucose tolerance test (GTT).

3.6.1 Glucose Tolerance Test (GTT)

After a night without food, the patient drinks a test dose of 100 g of glucose dissolved in a glass of water. The blood glucose concentration is measured before the test dose and at 30 min intervals for several hours thereafter. A normal individual assimilates the glucose readily, the blood glucose rising to no more than about 80 to 120 mg/100 ml; little or no glucose appears in the urine. Diabetic individuals assimilate the test dose of glucose poorly; their blood glucose level far exceeds the kidney threshold (about 180 mg/100ml), causing glucose to appear in their urine.

Exercises

I. Choose the correct answer from the given four alternatives

- a. Blood sugar is
i) sucrose ii) lactose iii) glucose iv) fructose
- b. Glycolysis occurs in
i) mitochondria ii) cytosol iii) nucleus iv) ribosome
- c. How many ATP molecules are generated during glycolysis
i) 2 ii) 10 iii) 6 iv) 8
- d. Which of the following enzyme links glycolysis and TCA cycle
i) glucokinase ii) PFK iii) LDH iv) pyruvate dehydrogenase
- e. Which one of the following enzyme is involved in substrate level phosphorylation
i) citrate synthase ii) isocitrate dehydrogenase
iii) succinyl CoA synthetase iv) fumarase
- f. How many irreversible steps occurs in glycolysis
i) 2 ii) 4 iii) 3 iv) 5
- g. The end product of glycolysis is
i) pyruvate ii) citrate iii) acetyl CoA iv) lactate

- h. The important reducing power produced in HMP shunt pathway is
 - i) NADH ii) NADPH iii) FAD iv) FADH₂
- i. Pyruvate is converted to oxaloacetate by
 - i) pyruvate carboxylase ii) pyruvate kinase
 - iii) PFK iv) phosphoenol pyruvate carboxylase
- j. Lactate is converted to glucose in
 - i) skeletal muscle ii) liver iii) kidney iv) lung
- k. Insulin is secreted by
 - i) liver ii) kidney iii) pancreas iv) thyroid

II. Fill up the blanks

- a. Glucokinase acts on glucose to form _____
- b. 2-phosphoglycerate is converted to _____ by the enzyme enolase.
- c. In the anaerobic phase one molecule of glucose produces _____ molecules of ATP
- d. Tricarboxylic acid cycle occurs in _____
- e. _____ is precursor for nucleotide synthesis
- f. Glycogen biosynthesis is known as _____
- g. The major source of glucose in ruminants is _____

III. Say true or false

- a. Phosphoglycerate kinase converts 1,3 bisphosphoglycerate to 3-phosphoglycerate.
- b. Pyruvate kinase acts reversibly
- c. 24 molecules of ATP are formed in TCA cycle
- d. UDP glucose pyrophosphorylase is involved in the synthesis of glycogen

- e. Degradation of glucose is also known as glycolysis
- f. Pyruvate is the end product of glycolysis

IV. Match the following

- | | | |
|-----------------------|---|--------------------|
| a. Glycolysis | - | Ribose 5-phosphate |
| b. PDH | - | Insulin |
| c. HMP shunt pathway | - | Cytosol |
| d. Debranching enzyme | - | Acetyl CoA |
| e. Diabetes mellitus | - | Glycogenolysis |
| f. TCA | - | Glycerol |
| g. Lipid | - | Mitochondria |

V. Give short answer for the followings.

1. What is the mean by aerobic and anaerobic phases?
2. Name the enzymes which are involved for NADH formation in TCA cycle
3. What is the difference between NADH and NADPH?
4. What is glycogenesis?
5. Write the three important irreversible reactions in glycolysis?
6. Explain the glycogenolysis
7. What are glucogenic amino acids?
8. How pyruvate is converted to lactate?
9. Write a short notes on GTT.

VI. Answer the following

1. What are the reaction sequences of glycolysis?
2. Describe the steps involved in TCA cycle
3. Explain the HMP shunt pathway
4. Give short note on cori cycle
5. What are the steps involved in glycogen metabolism?
6. How pyruvate is converted to glucose?
7. Explain the diabetes mellitus

CHAPTER IV

Protein Metabolism

Introduction

The biosynthesis of protein molecules in the cell by sequential addition of various amino acids using peptide bond is called protein synthesis. The amino acids are linked together in succession to produce a linear polypeptide chain. The polypeptide chain is a unit of a protein molecule.

4.1 Protein biosynthesis

In a protein molecule amino acids are joined together by peptide bonds. In the process of protein synthesis also known as translation of mRNA, the amino acids are added sequentially in a specific number.

The protein synthesizing mechanism involves the following steps:



4.1.1 Transcription

The formation of RNA complementary to a DNA strand is called transcription. In this process, the RNAs required for protein synthesis are synthesized on DNA strands. This reaction is catalyzed by the enzyme RNA polymerase.

The enzyme, RNA polymerase I, II, III are involved in the synthesis of rRNA (ribosomal RNA) mRNA (messenger RNA) and tRNA (transfer

RNA) respectively in the eukaryotes. In prokaryotes only one type of RNA polymerase is present to synthesize all the three classes of RNA.

In the DNA double helix, one of the strands serves as a template to produce RNA. The RNA produced by transcription is inactive and is called pre-RNA. They become active after further processing. All these RNA are processed through chemical reactions and structural modifications.

4.2 Translation

Translation is a process by which the base sequence of DNA transcribed to the mRNA is interpreted into amino acid sequence of a polypeptide chain.

Translation involves the following steps:

1. Activation of amino acid
2. Transfer of activated amino acid to tRNA
3. Initiation of polypeptide chain
4. Elongation of polypeptide chain
5. Termination of polypeptide chain

4.2.1 Activation of amino acid

Amino acids, the building blocks of proteins, are present in the cytoplasm. They are activated before they are transported by tRNA. The amino acids are activated by ATP with the help of the enzyme amino acyl synthetase. Amino acyl synthetase is specific in activating each amino acid.

The activated amino acid is called amino acyl adenylate or amino acyl AMP. Pyrophosphate is released.

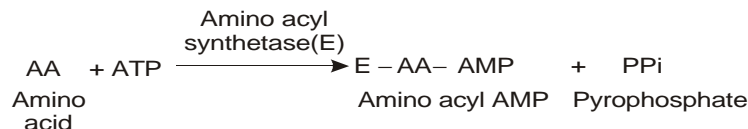

4.2.2 Transfer of activated amino acid to tRNA

The same enzyme that activates the amino acid catalyses its transfer to a molecule of transfer RNA at the 3' hydroxyl of the ribose, an ester with a high potential for group transfer. In this reaction AMP and the enzyme amino acyl synthetase are released.

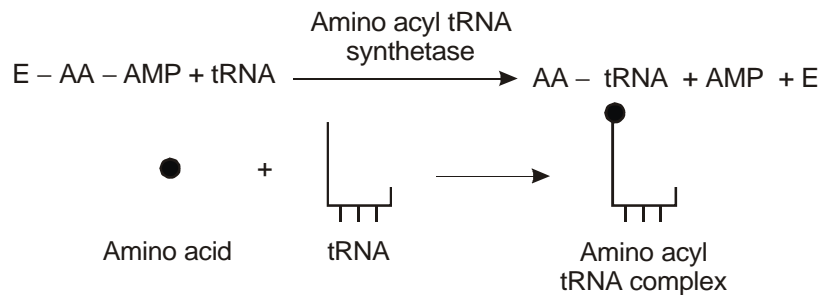

4.2.3 Initiation of polypeptide chain

Protein synthesis is initiated by the selection and transfer of the first amino acid into ribosomes. This process requires ribosome subunits, aminoacyl tRNA complex, mRNA and initiation factors (IF). Initiation of polypeptide chain involves the following steps.

1. The 30s ribosomal subunit attaches to the 5' end of the mRNA to form an mRNA 30s complex. This process requires the initiation factor IF-3 and Mg^{2+} ions. The attachment is made at the first codon of the mRNA.
2. The first codon of mRNA will be always AUG. This codon specifies the amino acid methionine. So the first amino acid in the synthesis of any polypeptide chain is methionine.

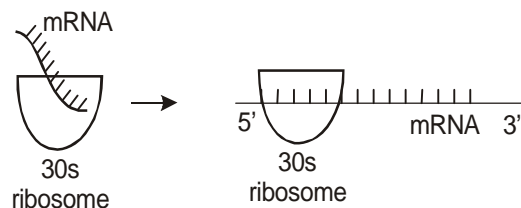

Fig.4.1 30s ribosomal subunit is attached to the 5' end of mRNA

- The tRNA having the anticodon UAC (complementary to AUG) transports methionine to the 30s ribosome and attaches itself to the initiation codon on mRNA. The tRNA, mRNA and 30s ribosome subunit form a complex called 30s - pre initiation complex. This process requires initiation factors and GTP.

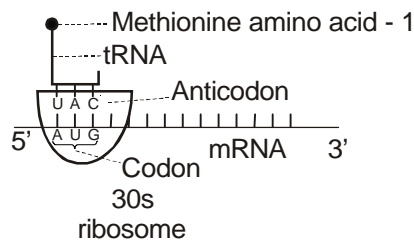

Fig.4.2 Formation of preinitiation complex

- 30s - pre initiation complex joins with 50s ribosomal subunit to form initiation complex. The initiation complex is formed of 70s ribosome, mRNA and met -RNA (methionine RNA).
- The 70s ribosome has two slots for the entry of amino acyl tRNA, namely P site (peptidyl site) and A site (amino acid site). The first tRNA i.e. met RNA is attached to the P site of 70s ribosome.

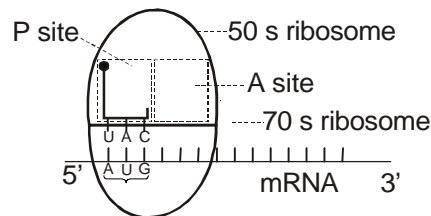

Fig.4.3 Formation of initiation complex

4.2.4 Elongation of polypeptide chain

Elongation refers to sequential addition of amino acids to methionine, as per the sequence of codon in the mRNA. It involves the following steps:

1. The second codon in the mRNA is recognised and as per the recognition, the amino acyl tRNA containing the corresponding anticodon moves to the 70s ribosome and fits into the A-site. Here the anticodon of tRNA base pairs with the second codon of mRNA.

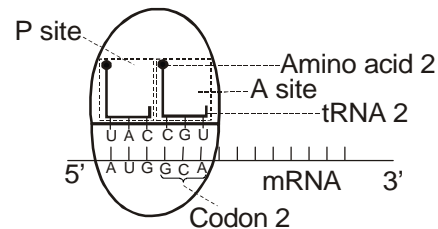

Fig.4.4 The second tRNA fits in A site of 70s ribosome

2. A peptide bond is formed between the carboxyl group ($-\text{COOH}$) of first amino acid of site P and the amino group ($-\text{NH}_2$) of second amino acid of A-site. The peptide bond links two amino acids to form a dipeptide. The bonding is catalysed by the enzyme peptidyl transferase which is present in 50s ribosomal subunit.
3. After the formation of peptide bond, the methionine and tRNA are separated by an enzyme called tRNA deacylase.
4. The dissociated tRNA is then released from P-site into the cytoplasm for further amino acylation.
5. Now the ribosome moves on the mRNA in the $5' \rightarrow 3'$ direction so that the first codon goes out of ribosome, the second codon comes to lie in the P-site from A-site and the third codon comes to lie in the A-site. Simultaneously, the second tRNA is shifted from A-site to P-site. All these events, the movement of ribosome, the release of first tRNA from P-site and shifting of second tRNA from A-site to

P-site constitute *translocation*. Translocation is catalyzed by the enzyme *translocase*.

- The third codon is recognised and the amino acyl tRNA containing the corresponding anticodon moves to the 70s ribosome and fits into the A-site. The anticodon base pairs with the codon. A peptide bond is formed between the third amino acid of site-A and the second amino acid of the dipeptide present in the P-site. Thus a tripeptide is formed.

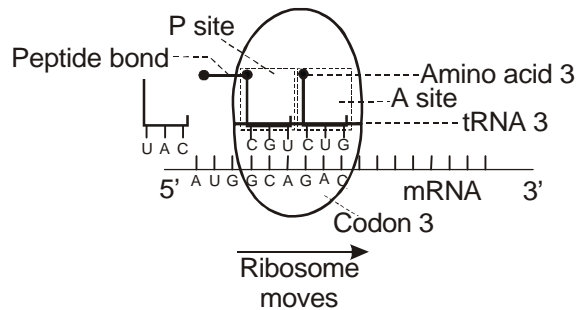

Fig.4.5 The ribosome moves in the 5' to 3' direction

- The amino acids are added one by one as per the codon in the mRNA and hence the tripeptide is converted into polypeptide chain. The polypeptide chain elongates by the addition of more and more amino acids.
- The elongation of polypeptide chain is brought about by a number of protein factors called elongation factors.

4.2.5 Termination of polypeptide chain

Termination is the completion of polypeptide chain. By termination, a polypeptide chain is finished and released. The polypeptide chain is completed, when the ribosome reaches the 3' end of mRNA.

The 3' end contains stop codons or termination codons. They are UAG or UAA or UGA. Termination is helped by the terminating protein factors. The terminated polypeptide chain is released from the ribosome.

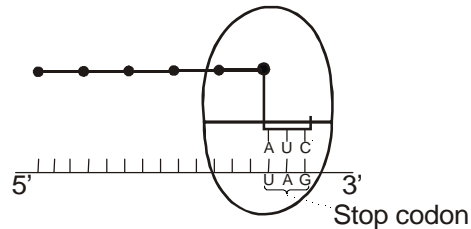

Fig.4.6 The ribosome reaches the termination or stop codon

After the release of polypeptide chain, the 70s unit dissociates into 50s and 30s sub-units. These subunits are again used in the formation of another initiation complex.

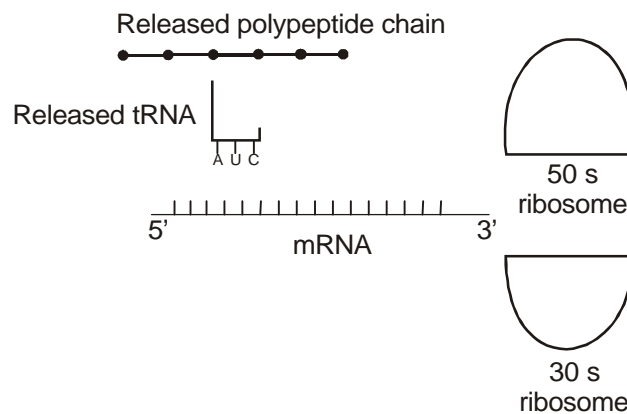

Fig.4.7 Termination of translation

The polypeptide chain released after translation is inactive. It is processed to make it active. In the processing the initiating amino acid methionine is removed. Along with methionine a few more amino acids are removed from the N-terminal of the polypeptide. The processing is carried out by deformylase and amino peptidase. This processing is called as post translational modifications.

4.3 Metabolism of Proteins

The ingested proteins are metabolised to amino acids by peptide bond cleaving enzymes known as proteinases.

4.3.1 General reactions of amino acids

The general reactions of amino acids include deamination, transamination and decarboxylation. The reactions of deamination and transamination bring about the formation of keto acids which can undergo a further series of changes. Inter-conversion between keto acids and amino acids results in the synthesis of many nutritionally non essential amino acids. These provide for the synthesis of protein and important non-protein nitrogenous materials. During protein synthesis the amino acids are absorbed from the blood, as the liver does not store them.

4.3.2 Catabolism of amino acids

Although each amino acid follows its own specific metabolic pathway, a few general reactions are found to be common in the catabolism of nearly all the amino acids. Most of the amino acids are converted to α -keto acids by the removal of nitrogen in the form of ammonia which is quickly transformed into urea or it gets incorporated into some other amino acids.

1. Oxidative deamination

Deamination means removal of the amino groups from amino acids. This is the mechanism where in the amino acids lose two hydrogen atoms (dehydrogenation) to form keto acids and ammonia.

Oxidative deamination is accompanied by oxidation and is catalysed by specific amino acid oxidases or more appropriately, dehydrogenases present in liver and kidneys. The process of oxidative deamination takes place in two steps.

The first step is oxidation (dehydrogenation) of amino acid resulting in the formation of imino acid. The imino acid then undergoes the second step, namely hydrolysis which results in a keto acid and ammonia.

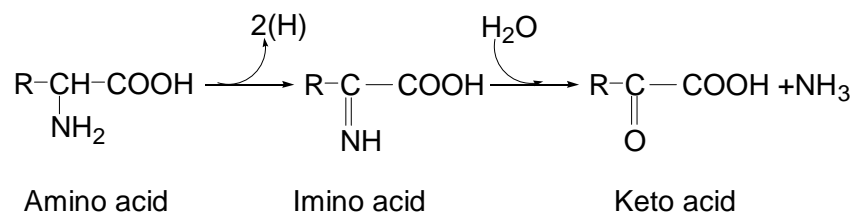

The first reaction is catalyzed by amino acid oxidase (also called dehydrogenase) and the coenzyme FAD or FMN takes up the hydrogen. There are two types of amino acid oxidases depending upon the substrate on which they act, namely,

1. L-amino acid oxidases which act on L-amino acids (FMN acts as coenzyme).
2. D-amino acid oxidases which act on D-amino acids (FAD acts as coenzyme).

FMN occurs only in the liver and kidney and FAD occurs in all animal tissues. The major site of oxidative deamination is liver but kidney and other tissues also have a role.

The oxidative deamination of L-glutamic acid is an exceptional case where the deamination needs not only the zinc-containing enzyme L-glutamic acid dehydrogenase but also NAD^+ or NADP^+ as coenzymes.

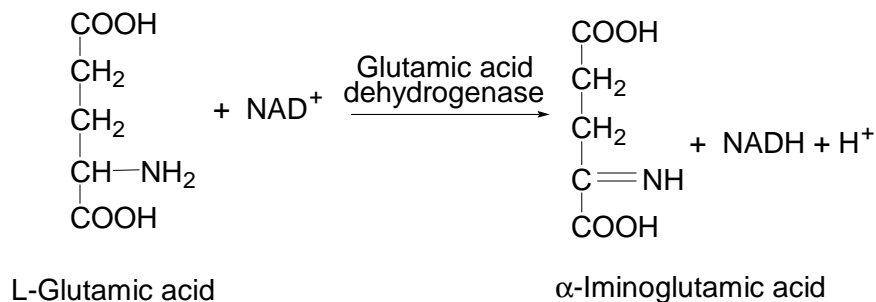

NADH gets oxidized to NAD⁺ as it passes through the electron transport chain.

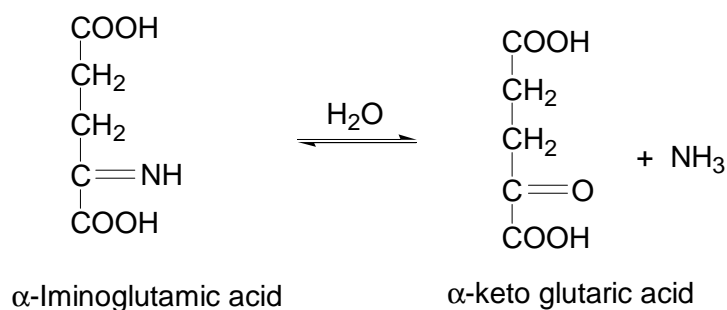

As the above reaction is reversible it occurs during both amino acid catabolism and biosynthesis.

2. Transamination

The process of transfer of an amino group from an amino acid to an α -keto acid, resulting in the formation of a new amino acid and keto acid is known as transamination. In other words, it is deamination of an amino acid, coupled with amination of a keto acid.

Transamination is catalyzed by transaminases or aminotransferases with pyridoxal phosphate functioning as coenzyme. There are two active transaminases in tissues, catalyzing interconversions. They are

1. Aspartate aminotransferase (AST) is also known as Glutamate - oxalo acetate transaminase (GOT)
2. Alanine aminotransferase (ALT) is also known as Glutamate - pyruvate transaminase (GPT)

1. AST

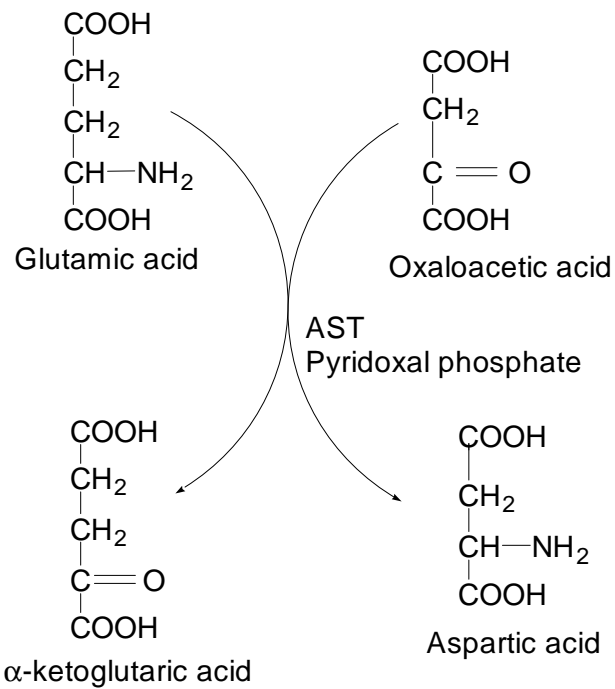
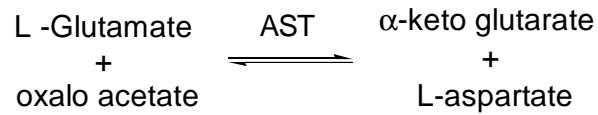

2. ALT

It catalyses the transfer of NH_2 group from glutamate to pyruvate, resulting in the formation of α -ketoglutaric acid and alanine.

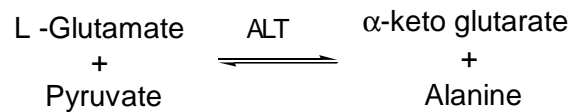

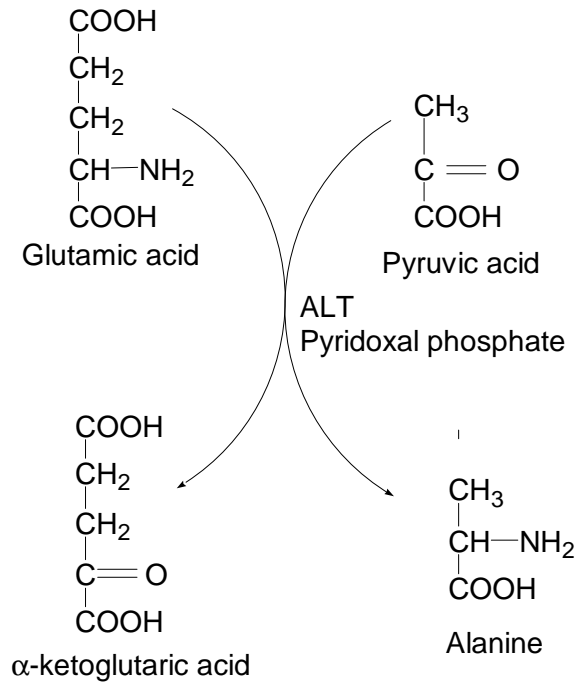

3. Decarboxylation

This refers to the removal of CO_2 from the carboxyl group of amino acids. The removal of CO_2 needs the catalytic action of enzymes decarboxylases and the pyridoxal phosphate coenzyme. The enzymes act on amino acids resulting in the formation of the corresponding amines with the liberation of CO_2 .

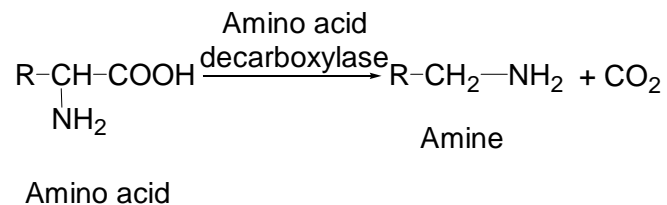

There are several amino acid decarboxylases found in various tissues such as liver, kidney, intestine, spleen, lung and brain. They convert the amino acids into the respective amines and liberate CO_2 . For example, histidine is converted to histamine by the action of histidine decarboxylase.

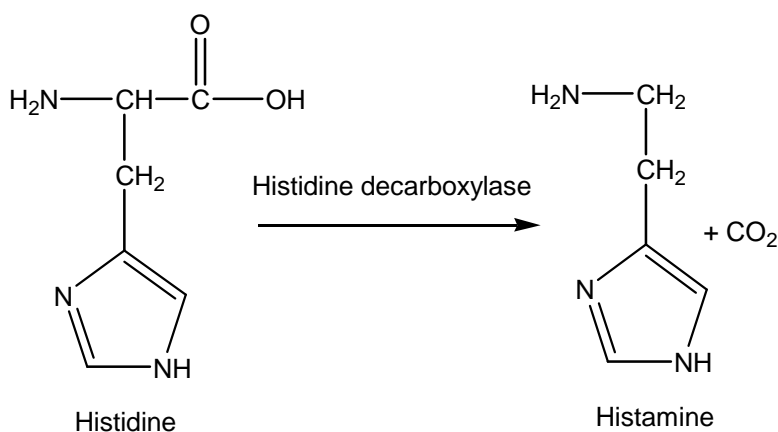

The amino acid tryptophan is converted to tryptamine, tyrosine to tyramine, etc. Such amines are called biogenic amines which are physiologically important.

4. Transmethylation

The transfer of methyl group from one compound to another is called transmethylation and the enzymes involved in the transfer are known as transmethylases.

Transfer of methyl group usually involves methionine (amino acid containing methyl group). By this process various important, physiologically active compounds such as epinephrine, creatine, thymine and choline are synthesised in the body. Detoxification of certain toxic substances are also carried out by this process (eg. nicotinic acid is detoxified by methionine into a nontoxic methyl derivative namely N-methyl nicotinamide).

Methionine is a principal methyl donor. It has to be activated by ATP which requires an methionine activation enzyme of liver, known as methionine adenosyltransferase. By the action of this enzyme, methionine is converted to active methionine.

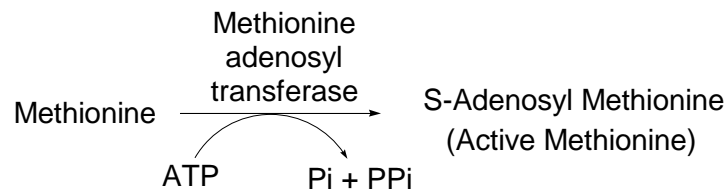

The active methionine thus formed is known as S-adenosyl methionine and in the activation reaction, ATP transfers its adenosine moiety to methionine and loses three molecules of phosphate, one as orthophosphate (Pi) and two as pyrophosphate (PPi).

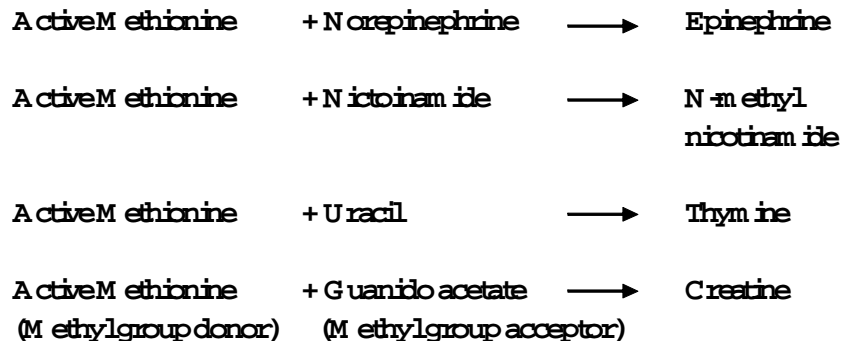

Active methionine contains S-methyl bond which is a high energy bond and hence methyl group is liable and can be easily transferred to a methyl group acceptor.

5. Catabolism of the carbon skeleton of amino acids

The carbon skeletons left behind after deamination are identified as α -keto acids. They may take any one of the following pathways.

i. Synthesis of amino acids

They may get reductively aminated by reversal of transdeamination or undergo transamination to form once again the original amino acids.

ii. Glucogenic pathway

The keto acids of some amino acids may get converted to the intermediates of carbohydrate metabolism such as α -keto glutarate, oxaloacetate, pyruvate, fumarate and succinyl CoA and hence could be converted to glucose and glycogen and these amino acids are said to be glucogenic amino acids.

The pathways of three important glucogenic amino acids are shown below. Though the routes vary with each amino acid, they all converge at the stage of pyruvic acid.

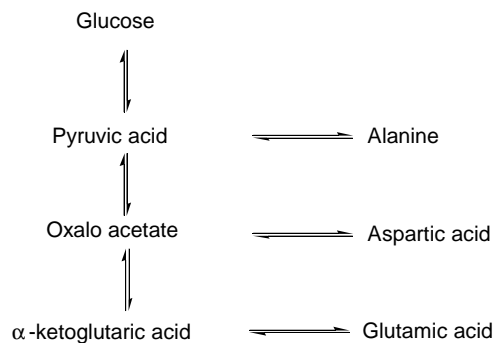

Glucogenic amino acids constitute more than 50% of the amino acids, derived from animal protein. The process of conversion of the keto acids of glucogenic amino acids to carbohydrate metabolites is known as gluconeogenesis.

iii. Ketogenic pathway

The keto acids formed from the deamination of certain amino acids are closely related to fats rather than carbohydrates. They metabolise to form acetyl CoA or acetoacetyl CoA or acetoacetate (ketone bodies)

which are the intermediates of fatty acid metabolism and not glucose and these amino acid are said to be ketogenic amino acids.

Ketogenic amino acids constitute only a minority and follow specialised and complex pathways. Examples are leucine, isoleucine, phenyl alanine and tyrosine. Among these, leucine is purely ketogenic, whereas the other three amino acids are both ketogenic and glucogenic.

4.4 Urea Cycle

Living organisms excrete the excess nitrogen resulting from the metabolic breakdown of amino acids in one of three ways. Many aquatic animals simply excrete ammonia. Where water is less plentiful processes have evolved that convert ammonia to less toxic waste products which require less water for excretion. One such product is urea, which is excreted by most terrestrial vertebrates; another is uric acid, which is excreted by birds and terrestrial reptiles.

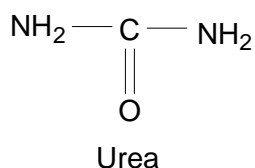

Accordingly, living organisms are classified as being either ammonotelic (ammonia excreting), urotelic (urea excreting) and uricotelic (uric acid excreting). Some animals can shift from ammonotelism to urotelism or uricotelism if their water supply becomes restricted.

Urea is synthesised in the liver by the enzymes of the urea cycle. It is then secreted into the blood stream and sequestered by the kidneys for excretion in the urine.

The urea cycle reactions were elucidated by Hans Krebs and Kurt Henseleit. This cycle starts with the amino acid ornithine. The cycle is confined only to the mitochondria and cytoplasm of the cells of liver and it

is found that the enzyme, arginase which is required in the final step of urea formation is present only in the liver and absent in all the other tissues.

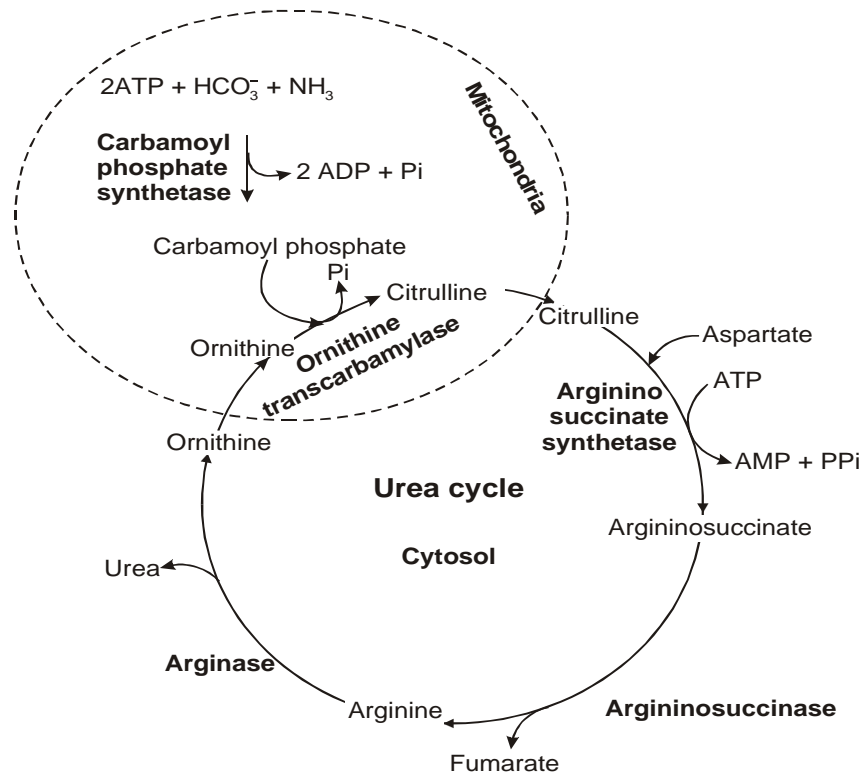
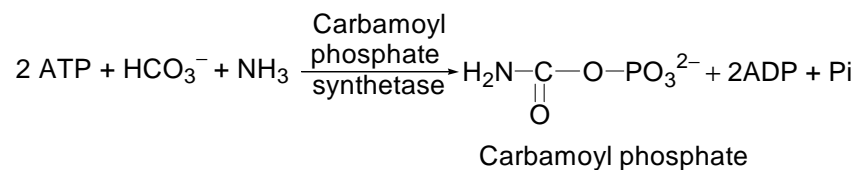

Fig. 4.8 Urea Cycle

Urea cycle occurs partially in the mitochondria and partially in the cytosol with ornithine and citrulline being transported across the mitochondrial membrane by specific membrane systems. The following are the various reactions in the process of urea formation.

1. Carbamoyl phosphate formation



Carbamoyl phosphate synthetase catalyses the condensation and activation of NH_4^+ and HCO_3^- to form carbamoyl phosphate.

2. Citrulline formation from ornithine

Ornithine transcarbamylase transfers the carbamoyl group of carbamoyl phosphate to ornithine, yielding citrulline.

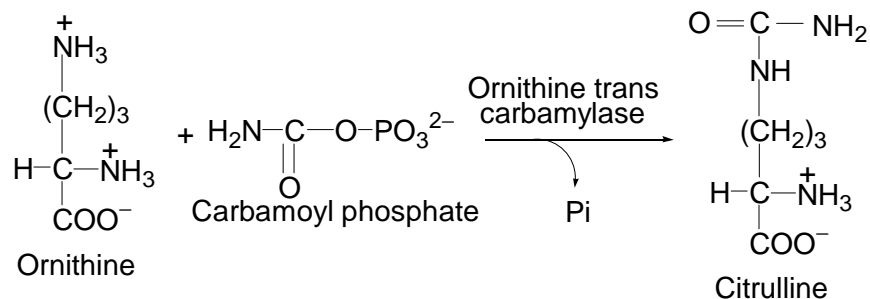

The reaction occurs in the mitochondria so that ornithine, which is produced in the cytosol, must enter the mitochondria via a specific transport system. Like wise, since the remaining urea cycle reactions occur in the cytosol, citrulline must be transported from the mitochondria.

3. Argininosuccinate formation

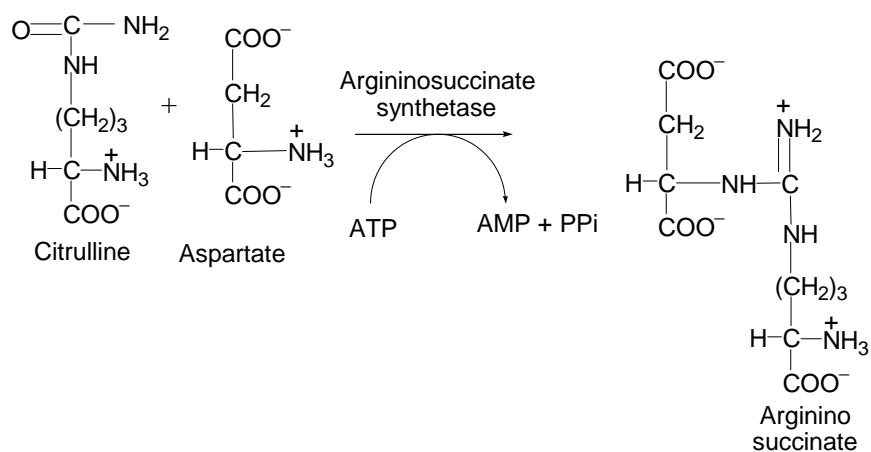

Citrulline undergoes condensation with amino group of aspartate to form argininosuccinate this reaction requires ATP, Mg^{2+} and the enzyme argininosuccinate synthetase.

4. Formation of arginine and fumarate

The enzyme argininosuccinase catalyses the elimination of arginine from the aspartate carbon skeleton forming fumarate.

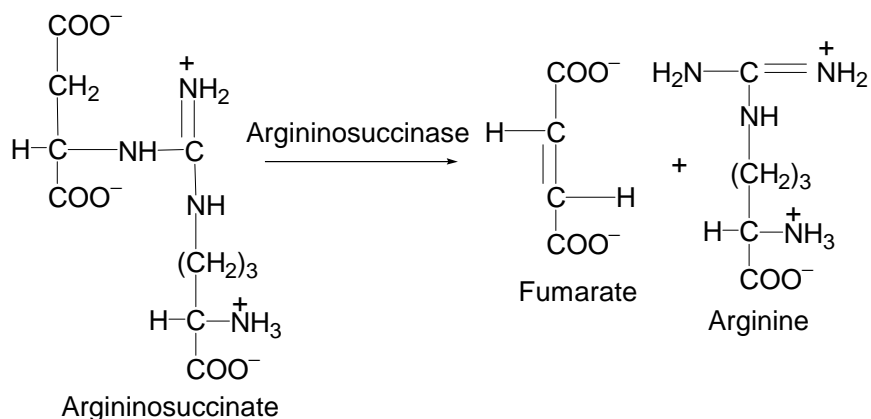

5. Formation of urea

The fifth and the final reaction in the urea cycle is the hydrolysis of arginine by the enzyme arginase to yield urea and ornithine.

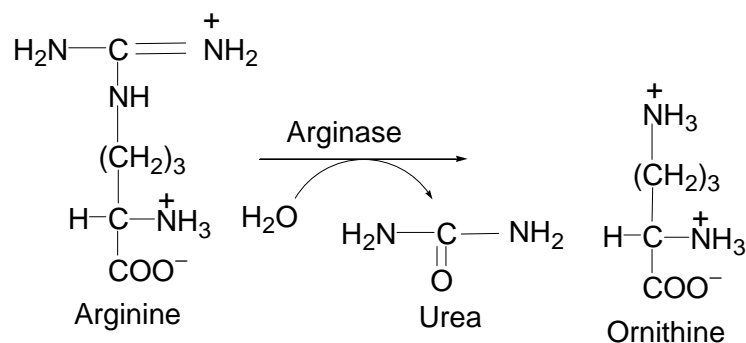

Ornithine is then returned to the mitochondria for another round of the cycle.

4.5 Formation of Niacin

Niacin is pyridine 3-carboxylic acid. Nicotinamide or niacinamide is the amide of nicotinic acid.

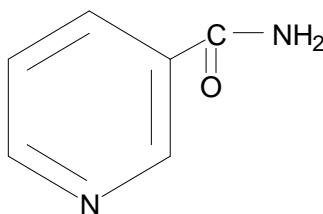

Nicotinamide

It derives its name from nicotine, from which it can be prepared by oxidation. In tissues, it is present as nicotinamide which is the physiologically active form. Nicotinamide, the active component in NAD⁺ and NADP⁺.

Niacin is synthesised in the body from tryptophan, an essential amino acid. Administration of tryptophan or proteins rich in tryptophan is followed

by increased excretion of niacin metabolites. Diets deficient in tryptophan produce a deficiency of niacin in the body.

The following scheme has been proposed by Hayaishi and others for the conversion of tryptophan into niacin in liver.

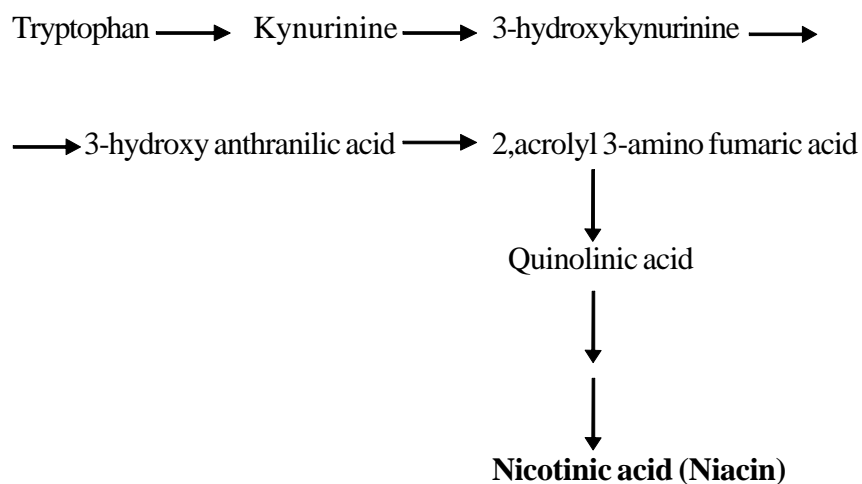

4.6 Formation of Melanin

The melanins, the pigments of skin and hair are complex polymers in which a major constituent is formed from tyrosine via dihydroxy phenyl alanine (DOPA).

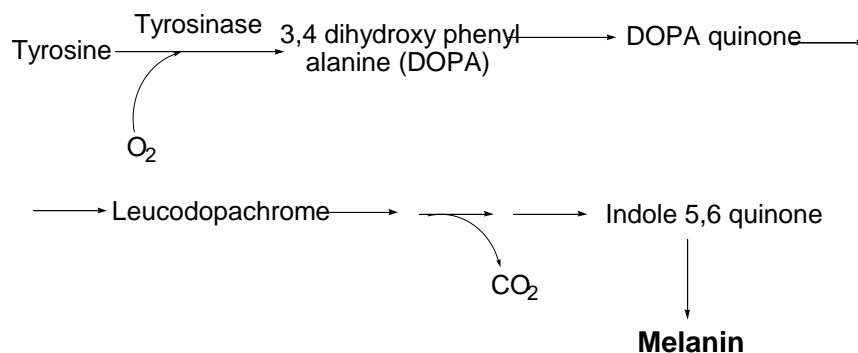

The formation of melanins from tyrosine, which occurs in animals, plants and certain bacteria (*B. niger*), is due to the action of polyphenol oxidases or tyrosinases. Tyrosinase, is a copper containing mixed function oxidase that carries out a tricky sequence.

While the melanins of human beings are derived from tyrosine through DOPA, most polyhydroxy phenyl and aminophenyl compounds having ortho or para groups can be oxidized to pigmented polymers and the type of melanin is best shown by indicating the substance from which the melanin is formed. Thus we may have dopa-melanin, adrenaline-melanin, homogentisic acid - melanin, p-phenylenediamine melanin etc.

Melanin forms a reversible oxidation - reduction system, in which the reduced form is tan and the oxidized form is black. Melanins appear in tissues as regular, spheroid granules and represent formed elements rather than precipitated aggregates. Melanins are produced in pigment - forming cells, the melanocytes, and their formation is stimulated by adrenal cortical and especially pituitary hormones.

4.7 Formation of thyroid hormone

The thyroid gland is a bilobed organ in the anterior portion of the neck. Thyroid gland in normal adult weighs 20-25 grams. Thyroxine the hormone is secreted by this gland. Thyroxine is stored in the colloid of the thyroid follicles, a form of glycoprotein called thyroglobulin.

Hydrolysis of thyroglobulin yields monoiodotyrosine, diiodotyrosine, triiodotyrosine and thyroxine. Of these, triiodothyroxine is considered to possess a biological potency greater than thyroxine.

Thyroxine is synthesised in thyroid gland from tyrosine. First inorganic iodide is oxidised to organic iodide ($2I \rightarrow I_2$). Tyrosine is iodinated in the third position to form 3 - monoiodotyrosine. The next iodination occurs in the fifth position to form 3,5-diiodotyrosine.

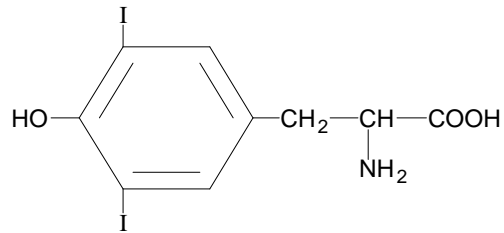

3,5-Diiodotyrosine

Two molecules of diiodotyrosine couple to form a mole of tetraiodotyrosine which is thyroxine. Alanine is liberated.

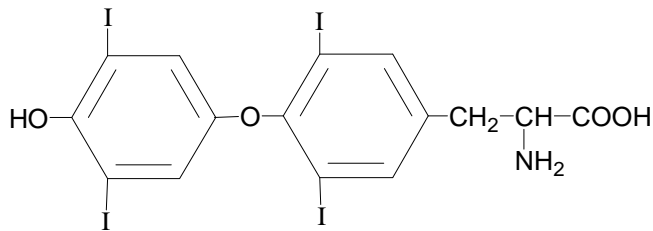
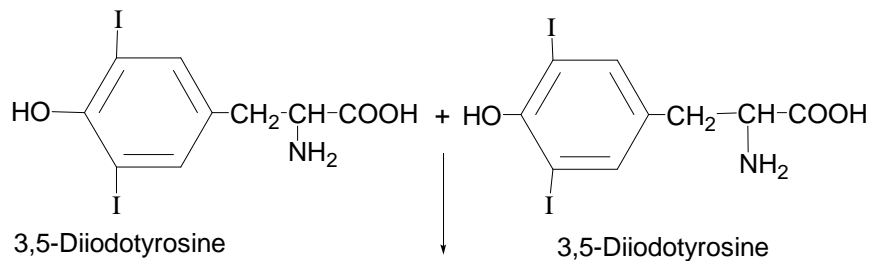

Thyroxine

+

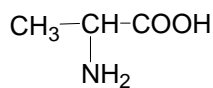

Alanine

Synthesis of thyroxine is accelerated by thyroid stimulating hormone (TSH) and inhibited by antithyroid drugs like thiocarbamides and aminobenzenes. Thyroid has the capacity of trapping inorganic iodine from circulation and storing it for utilization in the synthesis of thyroxine

and its precursors. Depending upon the need for thyroxine and its iodinated derivatives, a proteolytic enzyme hydrolyses thyroglobulin, under the stimulating influence of TSH.

4.8 Formation of catecholamines

The adrenal glands in the human adult are situated close to the upper pole of the kidneys and average 45 x 26 x 6 mm in size and weighs about 10g each. The adrenal gland is divided into two distinct portions - the medulla and cortex.

Catecholamines are secreted from the medullary portion of the adrenal gland.

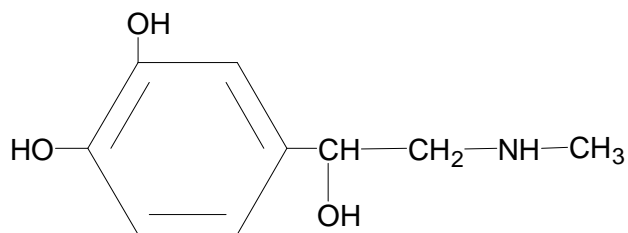

Epinephrine
(Adrenaline)

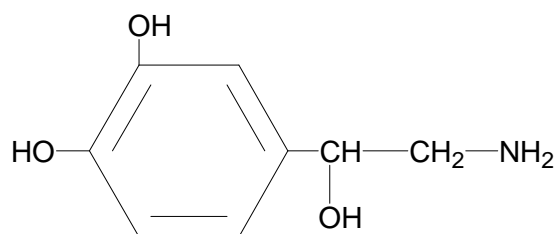

Norepinephrine
(Arterenol)

These two hormones, belonging to the catecholamine class of organic compounds, have potent biological activity in both metabolic and physiologic regulations. Epinephrine regulates carbohydrate metabolism, it has the effect of causing liver and muscle glycogenolysis, hyperglycemia and glucosuria. The hormone causes increased oxygen consumption, its effect being more rapid from that of thyroxine. Nor epinephrine causes increase in blood pressure by causing an increase in peripheral resistance. The hormone has, however, little effect on carbohydrate metabolism.

Tyrosine gets converted to form norepinephrine and epinephrine.

1. Tyrosine is first hydroxylated to 3,4-dihydroxyphenylalanine (DOPA) by a specific enzyme. DOPA is an intermediate which is common to the synthesis of both epinephrine and norepinephrine.

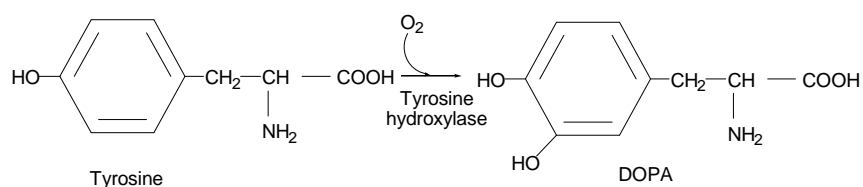

2. DOPA is next decarboxylated to dopamine by a decarboxylase in the presence of pyridoxal phosphate.

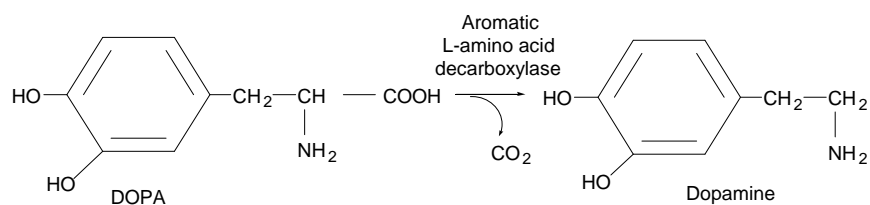

3. Next dopamine is oxidised to yield norepinephrine. The reaction is catalysed by dopamine hydroxylase and ascorbic acid.

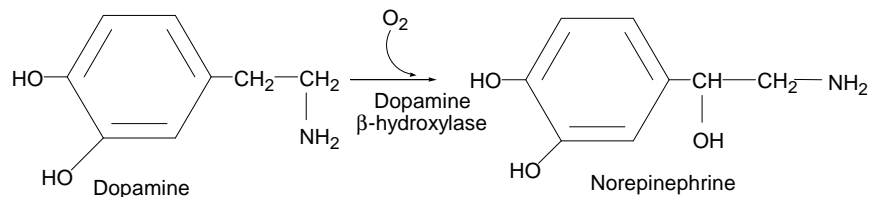

4. Methylation of norepinephrine in the medulla gives rise to epinephrine. The methyl group is derived from S-adenosyl methionine.

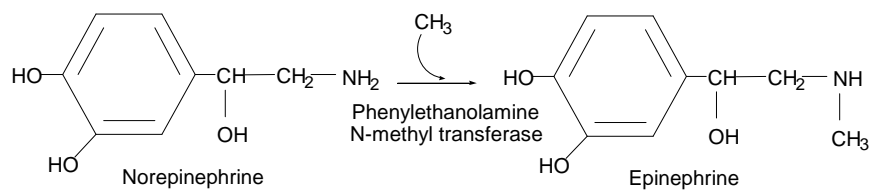

Exercises

- I. Choose the correct answer from the given four alternatives.**
- Which one of the following is codon for methionine
i) GUC ii) AUG iii) CGA iv) CGU
 - Amino acid is carried for protein synthesis by
i) mRNA ii) rRNA iii) tRNA iv) both mRNA and tRNA
 - The enzyme carbamoyl phosphate synthetase present in
i) mitochondra ii) cytosol iii) nucleus iv) cell membrane
 - Urea is formed from
i) citrulline ii) argininosuccinate iii) arginine iv) ornithine
 - Niacin synthesised in the body from
i) phenyl alanine ii) tyrosine
iii) lysine iv) tryptophan
 - GPT requires cofactor
i) NADH ii) NADPH iii) pyridoxal phosphate iv) FAD

II. Fill up the blanks

- a. Transcription process is catalyzed by the enzyme _____
- b. Protein synthesis is also called as _____
- c. _____ is formed by joining of 30s and 50s ribosome units.
- d. Translocation is catalyzed by the enzyme _____
- e. Stop codons present in _____ end of the mRNA
- f. _____ is produced by transmethylation reaction with uracil
- g. Synthesis of thyroxine is accelerated by _____
- h. _____ is pigment of skin and hair.
- i. Deamination of amino acids give _____

III. Say true or false

- a. Synthesis of RNA from DNA is known as transcription
- b. Anti codon is present in mRNA
- c. Ribosome moves from 5' to 3' direction
- d. The elongation of polypeptide chain is brought by elongation factors
- e. ALT is also known as GOT
- f. Peptidyl transferase is present in 30s subunit of ribosome
- g. Leucine is purely ketogenic amino acid
- h. Epinephrine is also called as adrenaline.

IV. Match the following

a. mRNA	-	Urea cycle
b. tRNA	-	Initiation complex
c. Histidine	-	Epinephrine
d. Ornithine	-	Active methionine.
e. DOPA	-	Anticodon
f. Thyroid gland	-	3' end of mRNA
g. Trans methylation	-	Histamine
h. Stop codon	-	Codon
i. GTP	-	Thyroxine

V. Give short answer for the followings

1. Explain the activation of amino acid.
2. What is elongation of polypeptide chain?
3. What is post translational modifications?
4. Name some biogenic amines.
5. How methionine is converted to active methionine?
6. How melain is synthesised from tyrosine?
7. Give the structure of thyroxine.
8. What are ketogenic aminoacids?
9. How niacin is formed?

VI. Answer the followings

1. What are the steps involved in the process of translation?
2. Give short notes on oxidative deamination.
3. Explain the transamination reactions.
4. Discuss the glucogenic and ketogenic pathways.
5. Write the reactions of urea cycle with structure.
6. Discuss the secretion of thyroxine from thyroid gland.
7. Explain the formation of epinephrine from tyrosine.

CHAPTER V

Lipid Metabolism

Introduction

Lipids are organic compounds of biological nature that includes fats, oils and waxes. They are insoluble in water but soluble in nonpolar solvents such as ether, chloroform and benzene. Lipids are utilizable by living organisms.

In the normal mammal at least 10 to 20 percent of the body weight is lipid. They form important dietary constituent on account of their high calorific value and fat soluble vitamins (vitamins A, D, E and K) along with the essential fatty acids. Lipids are distributed in all organs, particularly in adipose tissues in which lipids represent more than 90 percent of the cytoplasm of a cell.

Biological functions of Lipids

Lipids are stored in a relatively water - free state in the tissues in contrast to carbohydrates which are heavily hydrated to perform a wide variety of functions.

1. Body lipids are reservoir of potential chemical energy. Lipids can be stored in the body in almost unlimited amount in contrast to carbohydrates. Furthermore, lipids have a high calorific value (9.3 calories per gram) which is twice as great as carbohydrate. Large amount of energy is stored as lipid than as carbohydrates

2. Lipids which forms the major constituent of biomembranes are responsible for membrane integrity and regulation of membrane permeability.
- 3 The subcutaneous lipids serve as insulating materials against atmospheric heat and cold and protect internal organs.
4. They serve as a source of fat soluble vitamins (Vitamin A, D, E and K) and essential fatty acids. (Linoleic, Linolenic and Arachidonic acid).
5. Lipids serve as metabolic regulators of steroid hormones and prostaglandins.
6. Lipids present in inner mitochondrial membrane actively participate in electron transport chain.
7. Polyunsaturated fatty acids help in lowering blood cholesterol.
8. Squalamine, a steroid, is an potential antibiotic and antifungal agent.

Fatty acids

The fatty acids are the basic units of lipid molecules. Fatty acids are derivatives of aliphatic hydrocarbon chain that contains a carboxylic acid group. Over 200 fatty acids have been isolated from various lipids. They differ among themselves in hydrocarbon chain length, number and position of double bonds as well as in the nature of substituents such as oxy-, keto-, epoxy groups and cyclic structure. Depending on the absence, or presence of double bonds, they are classified into saturated and unsaturated fatty acids.

Saturated fatty acids, do not contain double bonds. The hydrocarbon chain may contain 12 to 18 carbon atoms. eg. palmitic and stearic acids.

$\text{CH}_3 (\text{CH}_2)_{14} \text{COOH}$ - Palmitic acid (C-16)

$\text{CH}_3 (\text{CH}_2)_{16} \text{COOH}$ - Stearic acid (C-18).

Unsaturated fatty acids are classified into different types depending on the number of double bonds present in the hydrocarbon chain. These fatty acids are mainly found in plant lipids.

Table 5.1 Unsaturated fatty acids

Name of Fatty Acid	No.of Double Bonds
Oleic acid	1
Linoleic acid	2
Linolenic acid	3
Arachidonic acid	4

Essential fatty acids

Fatty acids required in the diet are called essential fatty acids (EFA). They are not synthesized by the body and are mainly polyunsaturated fatty acids (PUFA).

eg. Linoleic acid
Linolenic acid
Arachidonic acid

Functions of essential fatty acids

They are required for membrane structure and function, transport of cholesterol, formation of lipoproteins and prevention of fatty liver.

Deficiency of essential fatty acids

The deficiency of essential fatty acid results in phrynoderma or toad skin.

5.1 Biosynthesis of fatty acids

1. Biosynthesis of fatty acids occurs in all organisms and in mammals it occurs mainly in adipose tissue, mammary glands, and liver.
2. Fatty acid synthesis takes place in the cytosol in two steps.
 - a) Formation of medium chain fatty acid of chain length 16 carbon atoms.
 - b) Lengthening of this carbon chain in microsomes for larger fatty acids.
3. Acetyl CoA serves as a source of carbon atoms for saturated as well as unsaturated fatty acids. Acetyl CoA can be formed from excessive dietary glucose and glucogenic amino acids (amino acids which can be converted to glucose). Carbohydrates and aminoacids in the presence of oxygen is converted to pyruvate which inturn can be converted to acetyl CoA..

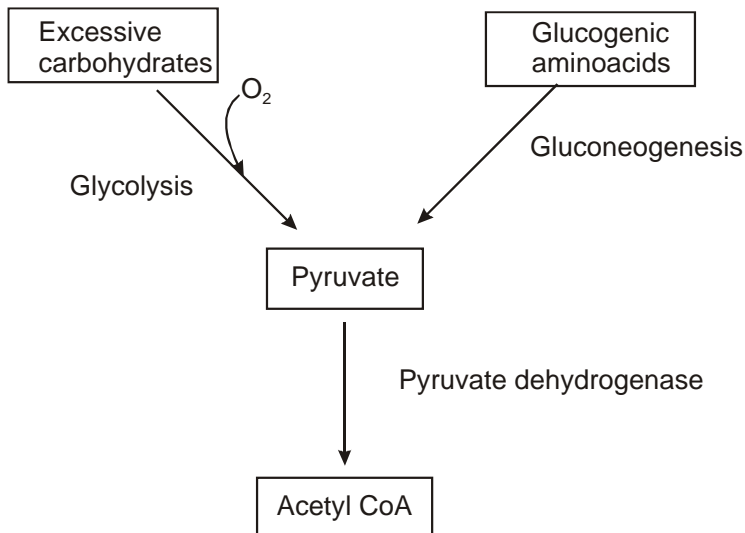

The synthesis of fatty acid from acetyl CoA takes place with aid of a multi-enzyme complex termed as fatty acid synthetase complex. Palmitic acid is the major product of the fatty acids synthetase complex mediated reaction and hence it is also called as palmitate synthetase. It is a dimer with two identical subunits namely subunit-1 and subunit-2 arranged in a head to tail fashion. Each monomer of this enzyme complex contains seven enzymes; of these, each is assigned a definite function.

Migration of Acetyl CoA for the bio synthesis of Fatty acids

Formation of acetyl CoA from pyruvate takes place in mitochondria. Mitochondrial membrane is impermeable to acetyl CoA. Migration of acetyl CoA from the mitochondria to the cytoplasm is facilitated by the condensation of the acetyl CoA with oxaloacetate to form citrate which is permeable to mitochondrial membrane. In the cytoplasm, citrate readily decomposed back to acetyl CoA and oxaloacetate in the presence of ATP and co-enzyme A by the action of an enzyme called ATP - Citrate lyase.

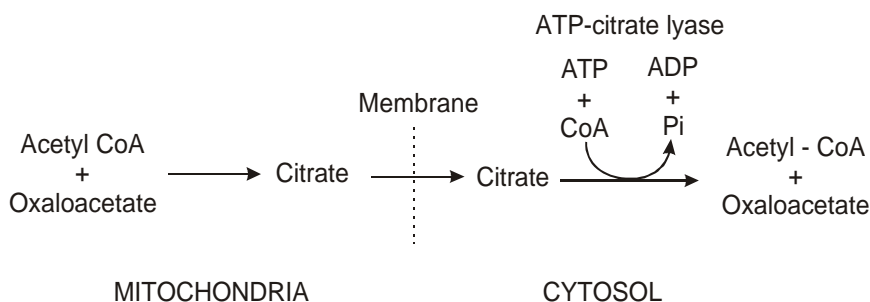

Conversion of Acetyl CoA to Malonyl CoA

The acetyl - CoA is carboxylated in the cytoplasm in the presence of acetyl CoA carboxylase, a vitamin Biotin containing enzyme, which helps in carbondioxide fixation. Acetyl CoA carboxylase is the regulatory enzyme in the fatty acid biosynthesis.

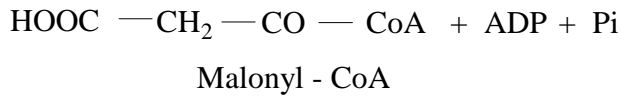
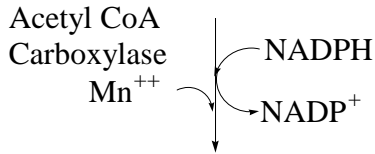
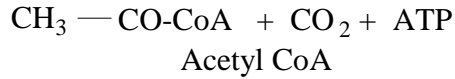

Conversion of malonyl CoA to palmitic acid

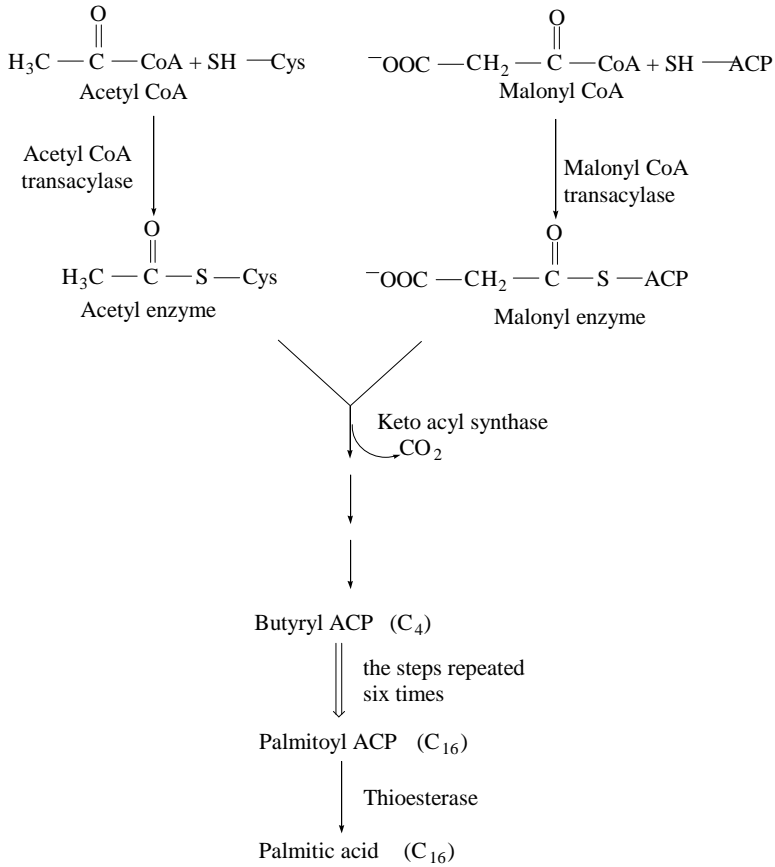

Fig. 5.1 Biosynthesis of palmitic acid

The malonyl CoA is converted to palmitic acid by several steps and each of these steps are catalysed by different enzymes of fatty acid synthetase complex.

Acetyl CoA and malonyl CoA condenses to form butyryl-ACP with the formation of intermediates. This cycle repeats itself six times and in each cycle two carbon atoms (malonyl CoA) is added to butyryl ACP, ultimately resulting in the formation of palmitoyl CoA, a 16 carbon molecule.

5.2 Oxidation of Fatty Acids

The digestion of fats starts in the small intestine. Fats are emulsified by the bile salts and hydrolysed by the pancreatic lipases to form free fatty acids. These free fatty acids combine with glycerol (produced by the glycolytic process) to form triglycerides. They combine with proteins to form lipoproteins and enter into circulation to perform various biological functions such as oxidation, storage and formation of new lipids. Thus the various fatty acids may exist in the free form as well as in the esterified form (Triglyceride) in blood.

Fatty acids are the immediate source for oxidation of fats in various tissues viz. liver, adipose tissue, muscles, heart, kidney, brain, lungs and testes.

5.2.1 β -Oxidation

Fatty acids are oxidised to CO_2 and water with the liberation of large amount of energy. Oxidation is brought about in the mitochondria because all the enzymes required for oxidation are present in the mitochondria. Oxidation of fatty acids is of three types, based on the position of the carbon atom which gets oxidised (α , β and γ).

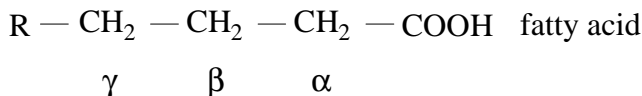

However β -oxidation of fatty acids is predominant and widely prevalent and it provides large amount of energy than α and γ oxidation. β -oxidation of fatty acids can be conveniently studied under different stages as detailed below.

I. Activation of fatty acids

Fatty acids are relatively inert chemical molecules and hence they must be converted to an active intermediate for the initiation of β -oxidation. The activation of fatty acids takes place in the cytosol in the presence of ATP, coenzyme A and acyl CoA synthetase. The activated fatty acid then enters into mitochondria with the help of a carrier protein, carnitine in the presence of an enzyme carnitine acyl transferase.

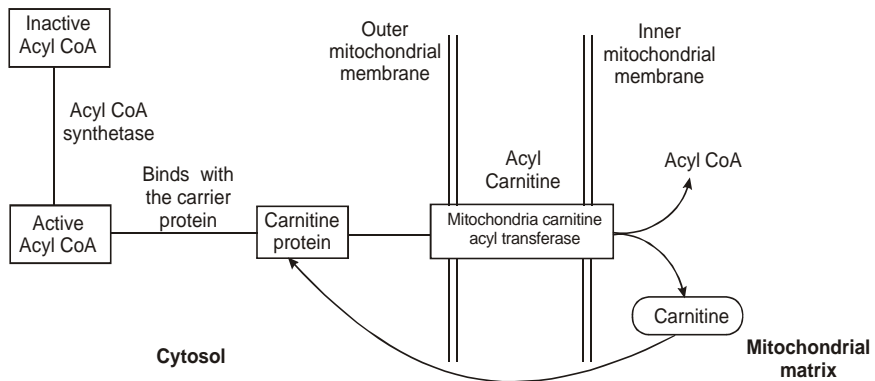

Oxidation of acyl CoA (fatty acid) takes place through several steps leading to the formation of acetyl CoA (C_2) and an acyl CoA having two carbon atoms less than the original fatty acid with which the β -oxidation cycle originally started. Acyl CoA then enters into a similar oxidation cycle until all the carbon atoms are released as acetyl CoA. These reactions require cofactors like Flavin Adenine Dinucleotide (FAD) and Nicotinamide Adenine Dinucleotide (NAD^+).

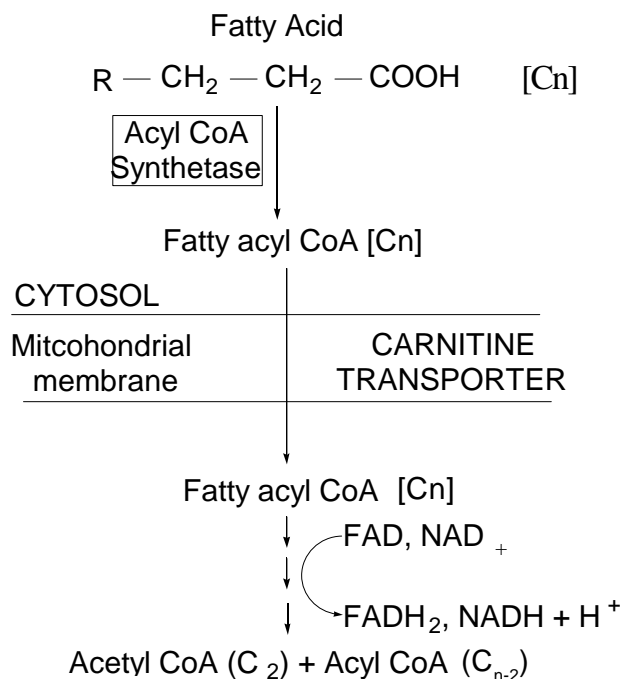
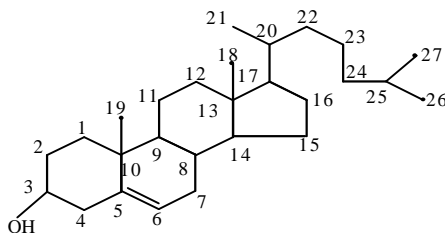

Fig.5.2 Schematic representation of b- oxidation

5.3 Cholesterol Biosynthesis

Cholesterol is an animal sterol which occurs either free or as fatty esters. As it was first isolated from human gallstones deposited in the bile duct, it is named as cholesterol (Greek word chole means – bile, sterol). Cholesterol is composed of 1,2-cyclopentanoperhydrophenanthrene ring system. Although cholesterol is an essential compound for life for the synthesis of hormones, bile acids and vitamin D, it is not necessary to supply it in the diet because it can be synthesised in the cell from acetyl CoA. Carbohydrates, amino acids, fatty acids and glycerol which gets converted to Acetyl CoA can also serve as a source for cholesterol synthesis. The liver plays a decisive role in the cholesterol metabolism which accounts for 90% of the overall endogenous cholesterol and its esters.

A man weighing 70 kg contains about 140 grams of cholesterol. The cholesterol concentration of blood in human is between 150 to 250 mg per 100 ml, being distributed equally between the cells and the plasma. The half life of cholesterol is about 8 to 12 days.



Structure of Cholesterol

5.3.1 Biosynthesis of cholesterol

Important intermediates of cholesterol Biosynthesis and enzymes involved.

1. Formation of acetyl CoA

A molecule of acetic acid combines with coenzyme A (CoA) to produce Acetyl CoA in the presence of an enzyme Acetyl CoA synthetase.

2. Formation of acetoacetyl CoA

Two molecules of acetyl-CoA condense to form an acetoacetyl-CoA molecule, catalyzed by the enzyme “thiolase”.

3. Formation of HMG CoA

The acetoacetyl-CoA further undergoes condensation with one more molecule of acetyl-CoA to form HMG-CoA (3-Hydroxy 3-Methyl Glutaryl-CoA). The enzyme which mediates this reaction is called HMG-CoA synthetase.

4. Formation of mevalonate

The HMG-CoA is reduced to form mevalonate by NADPH + H⁺ dependent reductase (HMG-CoA reductase). This is the rate limiting enzyme in the pathway of cholesterol biosynthesis.

5. Mevalonate thus formed is then converted to squalene through various steps.
6. Squalene, with the formation of various intermediates finally give rise to the end product cholesterol.

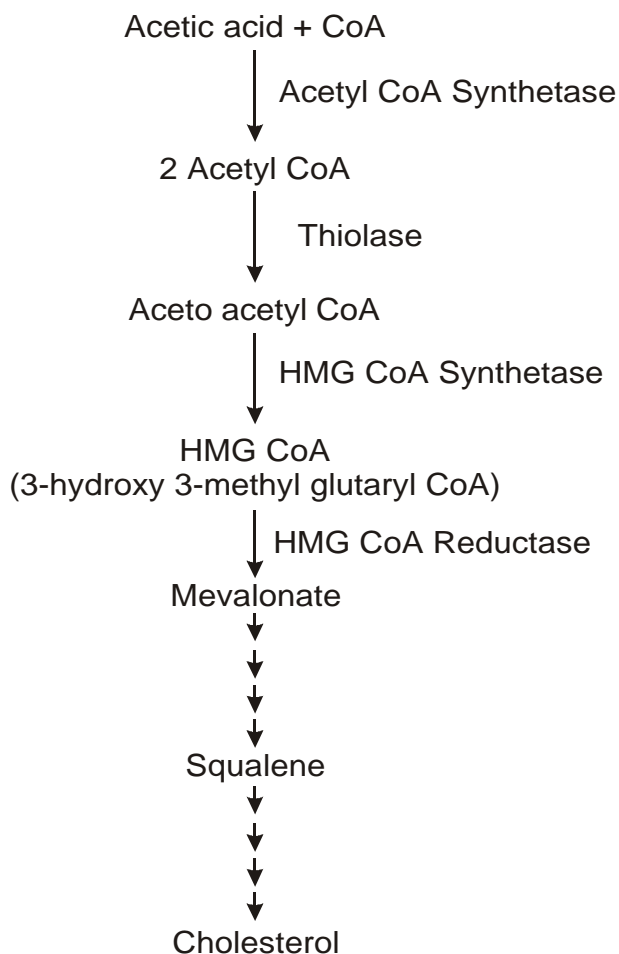

Fig.5.3 Biosynthesis of Cholesterol

5.3.2 Important products derived from cholesterol

In the body cholesterol is converted into several other types of biologically important steroids, viz. bile acids, bile salts and Vitamin D.

5.3.2.1 Synthesis of Bile Salts from Bile acids

Bile acids are of two types namely primary and secondary bile acids. Primary bile acids include cholic acid and chenodeoxy cholic acid and secondary bile acids include deoxycholic acid and lithocholic acid.

Importance

Bile acids are C₂₄ steroids, detergent like compounds that are responsible for the emulsification and absorption of lipids in the intestine.

Bile salts

Cholic acid is conjugated in the liver with either glycine or taurine through peptide linkages forming the bile salts glycocholic acid and taurocholic acid respectively. They combine with sodium and potassium present in the bile and form water soluble alkaline bile salts, namely sodium glycocholate and sodium taurocholate respectively.

Importance

- 1) Bile salts are the digestion promoting constituents of bile.
- 2) They lower surface tension and thus can emulsify fats.
- 3) They also activate lipases.

Vitamin D

Vitamin D is produced by irradiation of 7-dehydrocholesterol in the skin and in the kidney.

Importance

Vitamin D is a derivative of cholesterol and the precursor of parathyroid hormone which regulates calcium and phosphate metabolism in vertebrates.

Phospholipids

Phospholipids are so designated because they contain phosphoric acid. They are present in all cells, plants as well as animals. They are present both in cytoplasm as well as in the cell membranes and serve important functions in both cell activity and cell permeability. Phospholipids are made up of fatty acids, nitrogenous base, phosphoric acid and glycerol or other alcohol. Phospholipids can be classified based on the alcohol moiety of the phospholipid as follows.

1. Glycerophosphatides

Glycerol is the alcohol moiety in this group. This includes lecithins, cephalins, phosphatidyl serine, plasmalogens and diphosphatidyl glycerols.

2. Phosphoinositides

In this the cyclic hexahydric alcohol “inositol” replaces the nitrogenous base.

3. Sphingolipids

In this group of substances, glycerol is replaced by a complex amino alcohol “Sphingosine”. These are clinically important phospholipids in human.

5.4 Biosynthesis of phospholipids

All tissues synthesize phospholipids, but at different rates. In all tissues except liver, phospholipids are synthesized, utilised and degraded

in situ; while in liver large proportion of the phospholipids after synthesis is transferred to the plasma and as a matter of fact, liver is practically the sole source of plasma phospholipids. Phospholipids are mainly synthesized from glycerol as detailed below.

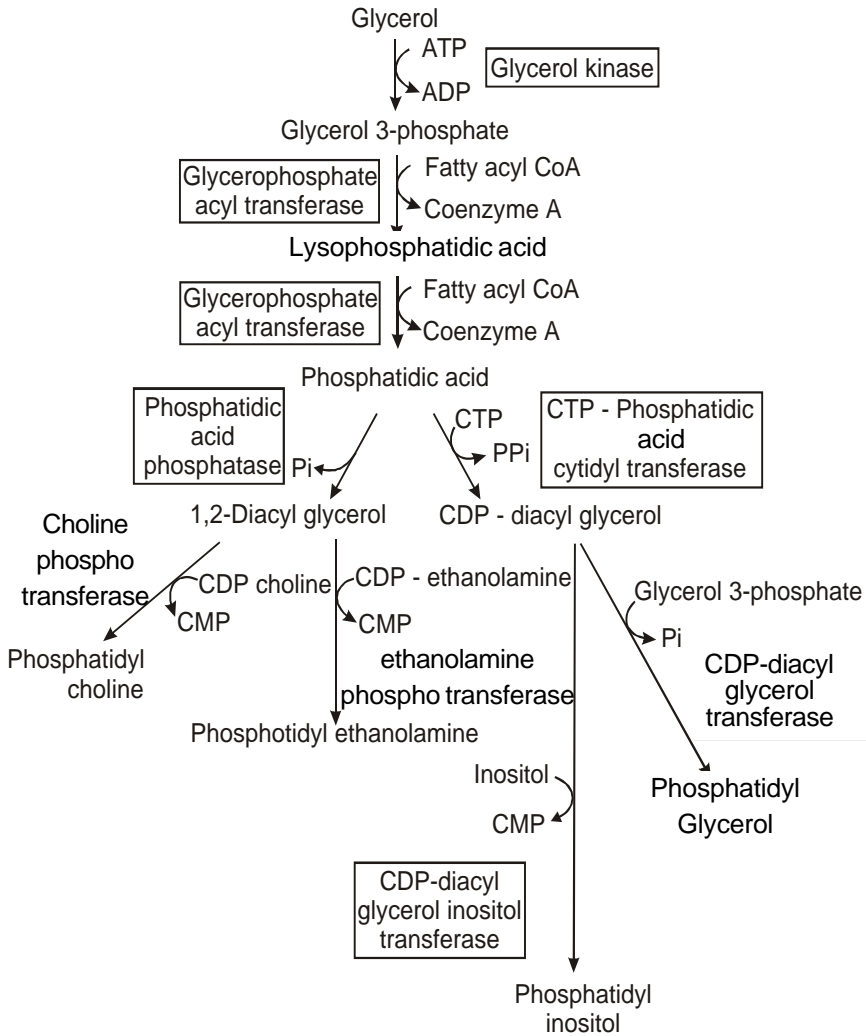

Fig. 5.4 Biosynthesis of phospholipids

5.4.1 Biosynthesis of Lecithins

Lecithins are otherwise called as phosphatidyl choline. The choline component of lecithins is derived by the stepwise methylation of ethanolamine which in turn is formed by the decarboxylation of serine. Serine is derived from the pathways of both carbohydrate and protein metabolism as shown below.

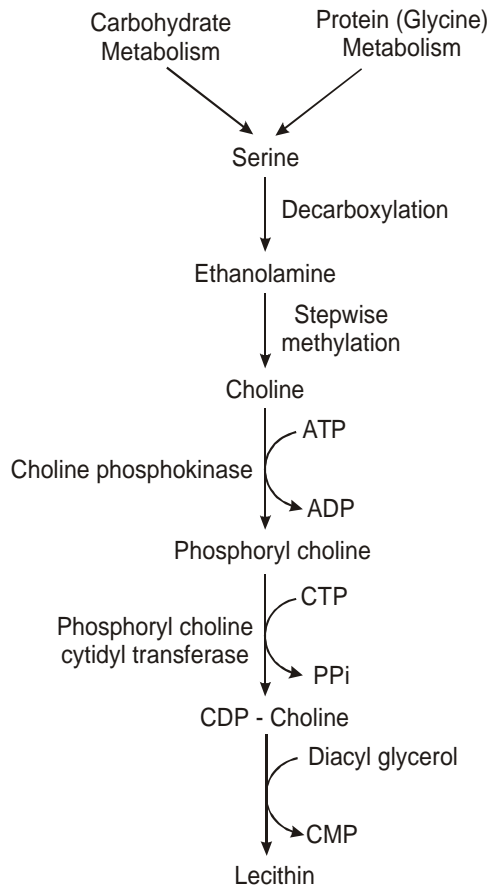
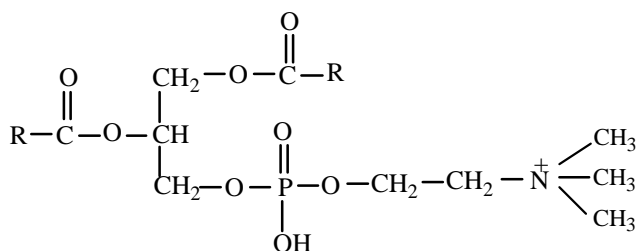

Fig. 5.5 Biosynthesis of lecithin



Lecithin

Structure of lecithin

5.4.2 Degradation of phospholipids by enzymes

Degradation of phospholipids are effectively catalysed by a group of hydrolytic enzymes known as phospholipases. Phospholipases are classified into four major types namely phospholipase A_1 , A_2 , C and D. The classification is based on their cleavage specificity.

5.4.3 Lysolecithin formation

Lecithin is hydrolysed by the enzyme lecithinase. The lecithinases are also known as phospholipases. When lecithin is acted upon by the enzyme phospholipase A_2 it is converted into lysolecithin and a free fatty acid.

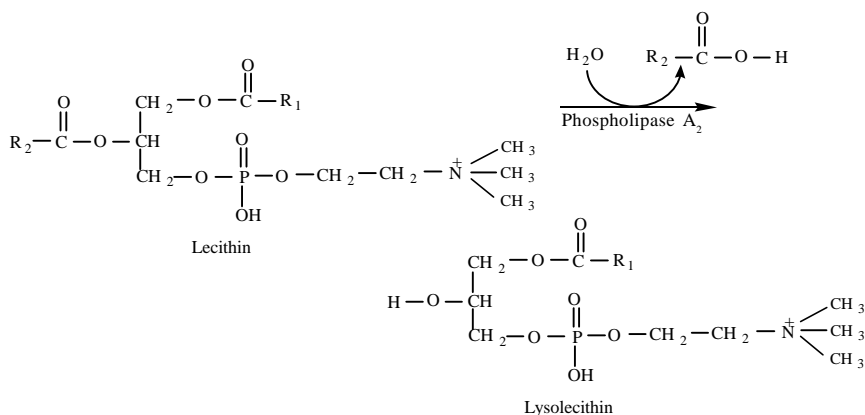

Lysolecithin may also be formed by an alternative route involving lecithin cholesterol acyl transferase. This enzyme is synthesized in liver and found in plasma in appreciable amounts. This enzyme transfers the fatty acid moiety from the lecithin to the cholesterol to form cholesterol ester. Lysolecithin accounts much of the cholesterol ester in plasma.

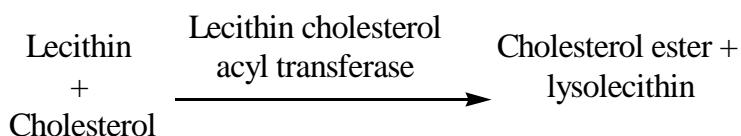

5.4.4 Effects of lysolecithin

Lecithinases are specific enzymes which hydrolyse lecithins to form free fatty acids, glycerol, phosphoric acid and choline. A lecithinase in cobra venom readily split off an unsaturated fatty acid in lecithin producing “lysolecithin”. As the name implies, lysolecithin is a potent red blood cell hemolysing agent. This is the explanation of the toxicity of snake venom, bee-sting and certain poisonous spiders.

5.5 Cephalin

The cephalins are structurally identical with the lecithins with the exception that the base ethanolamine instead of choline is present. The cephalins are otherwise called as phosphatidyl ethanolamine.

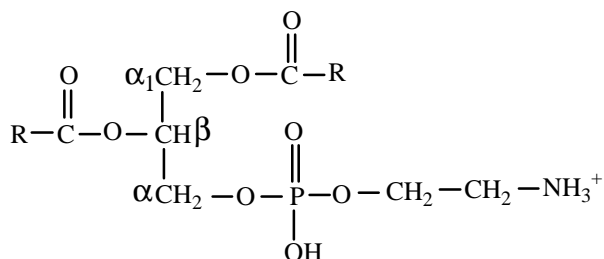

Structure of Cephalin

The physical properties of the cephalins are similar to those of lecithins. Cephalins are differentiated by the presence of different fatty acid groups in the molecule. Lecithinase from snake venom hydrolyses cephalins to lysocephalins which are similar to the formation of lysolecithin from lecithin.

5.6 Atherosclerosis

The synthesis, transport and storage of cholesterol in mammals is regulated by a number of mechanisms. Defects in these lead to many pathological abnormalities; most common of which is atherosclerosis. Atherosclerosis is manifested by deposition of cholesterol and other lipids on the inner walls of blood vessels. This leads to occlusion of blood vessels in the heart and the brain, resulting in increased blood pressure, strokes and heart attacks. The causative factors for atherosclerosis include, smoking, obesity, lack of physical exercise, emotional stress and high fat diet.

Atherosclerotic individuals always have increased levels of VLDL and LDL in plasma. Though many hypolipidemic drugs are commercially available to control the cholesterol levels, they often elicit harmful side effects. Diet control and physical exercise are often recommended for controlling atherosclerosis.

Exercises

I. Choose the correct answer from the four alternatives.

- a. Which one is a saturated acid?
- | | |
|--------------------|---------------------|
| i) Oleic acid | ii) Cerebronic acid |
| iii) Nervonic acid | iv) Stearic acid |
- b. _____ is not an essential fatty acid.
- | | |
|-----------------------|--------------------|
| i) Linoleic acid | ii) Linolenic acid |
| iii) Arachidonic acid | iv) Oleic acid |

IV. Match the following

- | | | | |
|----|------------------------|---|---------------------------|
| 1. | Lecithin | - | Cholesterol biosynthesis |
| 2. | Cephalin | - | Bile salt |
| 3. | Acetyl CoA carboxylase | - | Phosphatidyl choline |
| 4. | Cholic acid | - | Fatty acid biosynthesis |
| 5. | HMG CoA reductase | - | Phosphatidyl ethanolamine |

V. Given one word answer

1. What type of fatty acids help in lowering blood cholesterol?
2. Which steroid is used as an antifungal agent?
3. Name the enzyme that converts acetyl CoA to malonyl CoA.
4. How many cycles of β oxidation are needed to convert palmitic acid to acetyl CoA?
5. Name the cyclic hexahydric alcohol present in phospholipids.

VI. Answer the following briefly

1. Give an account on oxidation of fatty acids.
2. Briefly discuss the various steps involved in cholesterol biosynthesis.
3. List the biological functions of lipids.
4. Give an account on atherosclerosis.
5. How fatty acids are synthesized in our body?

CHAPTER VI

Nucleic Acid Metabolism

Introduction

Nucleic acids are the chemical basis of life and heredity. They serve as transmitters of genetic information. As the name implies, their location is mainly in nuclei. However, it is also found to be present in other intracellular organelles. Nucleic acids are present both in the free state as well as conjugated with proteins (Nucleoproteins). Like amino acids in proteins, nucleotides are the basic units of nucleic acids. There are two types of nucleic acids namely,

1. Ribonucleic acid
2. Deoxyribonucleic acid

Structural Components of Nucleic acids

Components	Ribonucleic acid	Deoxyribonucleic acid
Acid	Phosphoric acid	Phosphoric acid
Pentose Sugar	D-ribose	D-2 deoxy ribose
Nitrogen Bases		
i. Purines	Adenine Guanine	Adenine Guanine
ii. Pyrimidines	Cytosine Uracil	Cytosine Thymine

Phosphoric acid

The molecular formula of phosphoric acid is H_3PO_4 . It contains 3 monovalent hydroxyl groups and a divalent oxygen atom, all linked to a pentavalent phosphorus atom.

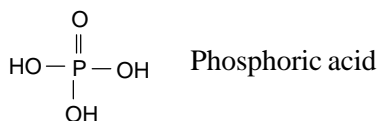

Pentose Sugar

The two types of nucleic acids are distinguished primarily on the basis of the 5 carbon sugar pentose which they possess. One possesses D-2-deoxyribose, (deoxyribonucleic acid) while the other contains D-ribose (hence called ribonucleic acid). Both these sugars in nucleic acids are present in the furanose form and are of β configuration.

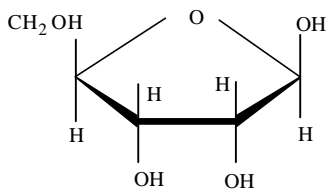

β -D-Ribose

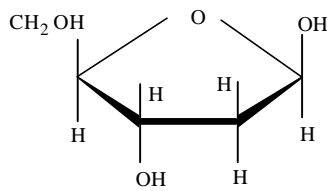

β -D-deoxyribose

Nitrogenous Bases

Two types of nitrogenous bases are found in all nucleic acids. These are derivatives of purine and pyrimidine.

i. Purine Bases

These are all derived from their parent compound purine, which contains a six membered pyrimidine ring fused to the 5 membered imidazole ring, the purine derivatives found in nucleic acids are adenine and guanine.

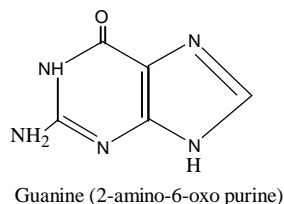
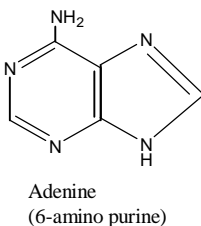
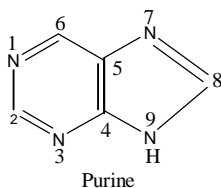

ii. Pyrimidine Bases

These are all derived from their parent heterocyclic compound pyrimidine. The common pyrimidine derivatives found in nucleic acids are Uracil, Thymine and Cytosine.

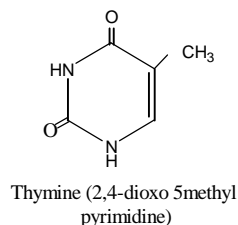
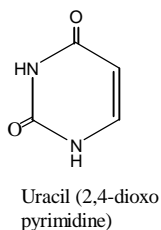
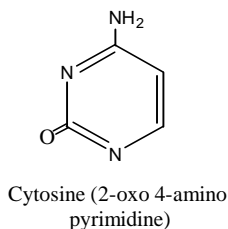
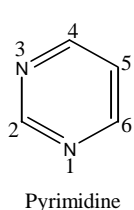

Minor bases in nucleic acid

Apart from the above four bases, certain minor, unusual bases are also found in DNA and RNA. They are 5 methylcytosine, N⁴ acetyl cytosine, N⁶ methyladenine, N⁶, N⁶ dimethyladenine and pseudouracil etc.,

Base Pairing

Base pairing is an essential feature not only to maintain the double helical structure of DNA, but also plays an important role in DNA, RNA and protein biosynthesis.

In DNA

Adenine (A) pairs with thymine (T) (A=T)
Guanine (G) pairs with cytosine (C) (G≡C)

In RNA

Adenine (A) pairs with uracil (U) (A=U)
Guanine (G) pairs with cytosine (C) (G≡C)

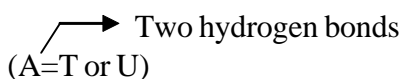
 Two hydrogen bonds
(A=T or U)

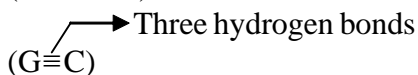
 Three hydrogen bonds
(G≡C)

Chargaff's rule of DNA composition

DNA has equal number of adenine and thymine residues (A=T) and equal number of guanine and cytosine (G=C) residues. This is known as Chargaff's rule of molar equivalence between purine and pyrimidines in DNA.

Structure of Nucleotides

Nucleotides are the fundamental units of nucleic acids. Each nucleotide is comprising of a

i) Phosphate group ii) Pentose Sugar and iii) Nitrogenous base.

Sugar + Base \longrightarrow Nucleoside
Nucleoside + Phosphate \longrightarrow Nucleotide

6.1 Biosynthesis of DNA

The process by which the new double helical DNA synthesized from the existing DNA is called as "Replication". The mechanism of biosynthesis of DNA has been largely clarified by the discovery of the

enzyme DNA Polymerase or DNA Nucleotidyl transferase. This enzyme catalyses the polymerization of mononucleotides to polynucleotides, which needs the following for its action.

1. A template strand dictates the synthesis of the new daughter strand and sequence of the template strand determines the addition of the nucleotides.
2. RNA primer to which subsequent nucleotides can be added.
3. Four nucleoside triphosphates namely, dGTP, dATP, dTTP and dCTP.
4. Magnesium ions as co-factor.

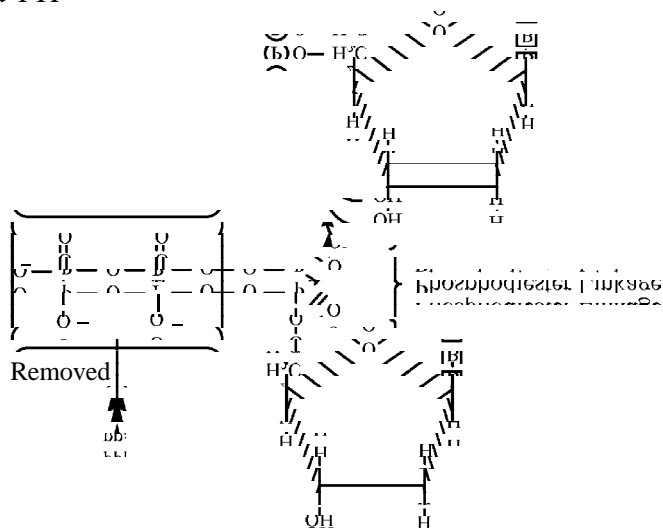
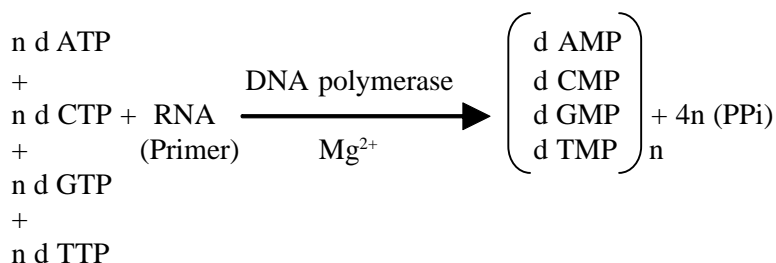

Fig.6.1 Formation of Phosphodiester linkage

The energy required for this reaction is provided by the hydrolysis of high energy bonds in the linear triphosphate units of the dATP, dCTP, dGTP & dTTP. As each monomer is incorporated into new chain, it loses its terminal pyrophosphate unit (PPi).

6.1.1 Replication

It is a process in which DNA copies itself to produce identical daughter molecules of DNA.

Models of Replication

Three models of replication had been proposed. They are 1. Conservative replication 2. Dispersive replication and 3. Semi conservative replication.

1. Conservative replication

According to this model, the parental DNA is conserved to one daughter cell and the newly synthesized DNA to another daughter cell.



Parent DNA

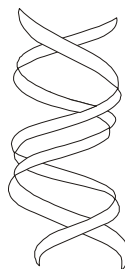

**Newly synthesized DNA
(daughter DNA)**

Fig. 6.2 Conservative model of Replication

2. Dispersive Replication

According to this model, the parental DNA is unequally distributed (randomly) to the daughter cells.

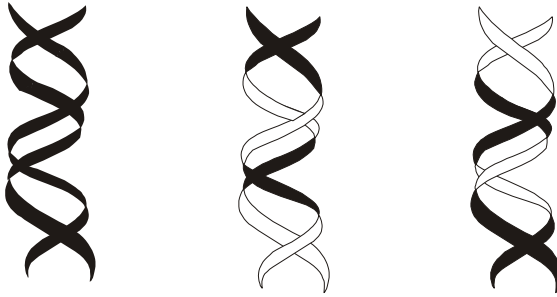

Fig. 6.3 Dispersive model of Replication

3. Semiconservative Replication

Semiconservative model of replication showing the daughter DNA having one parental strand and one daughter strand.

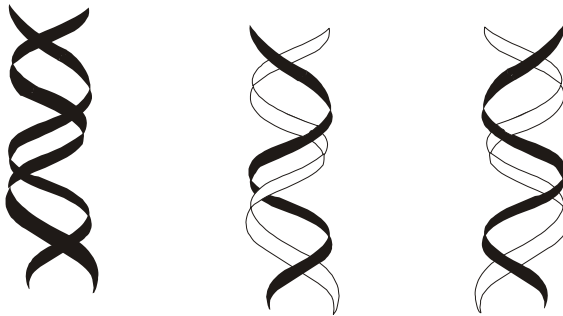

Fig. 6.4 Semiconservative model of Replication

This model was established to be the correct mode of replication by the experiment carried out by Messlson and Stahl in 1957. *E. coli* cells were grown in a medium containing $^{15}\text{NH}_4\text{Cl}$, for many generations

such that the *E. coli* cells have density labelled ^{15}N atoms in their DNA. The cells were then grown in a medium containing unlabelled NH_4Cl . DNA was harvested from the daughter cells after one generation and the density of the DNA was analyzed using Cesium chloride density gradient centrifugation. If replication happens to occur by conservative model, two bands are corresponding to heavy DNA and other unlabelled DNA should be got. But if replication is semi-conservative, daughter DNAs should possess one labelled strand and one unlabeled strand, so they will form only one band with intermediate density. The results show that they form bands with intermediate density alone in the first generation, which confirms the semiconservative model of replication.

6.1.2 Sequential Process of Replication

Initiation of DNA replication

Initiation of DNA synthesis occurs at a site called origin of replication.

In prokaryotes, only one origin.

In eukaryotes, there are multiple origins.

The origin consists of a short sequence of A = T base pairs.

Replication bubbles

The two complementary strands of DNA separate at a site of replication to form a bubble. In eukaryotes many replication bubbles occur.

Unwinding of parental DNA

After the initiation point is located the unwinding of the DNA takes place once in every 10 nucleotide pairs. This allows the “strand separation”.

In prokaryotes the unwinding of the structure occurs with the help of an enzyme called helicase, which requires energy of hydrolysis of

two ATP molecules per base pair broken. Another protein single strand binding protein (SSB), binds to the unwound DNA to prevent (rewinding) rejoining.

As the DNA polymerase cannot initiate replication a primer is a needed and the primer is the small nucleotide of RNA, synthesised by enzymes primase.

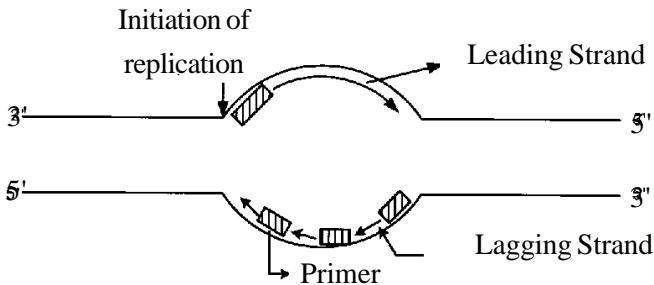

Fig. 6.5 Initiation of Replication

Under the influence of DNA polymerase, in the presence of Mg^{2+} , the double strands of the DNA acting as a template (or primer) separate by cleaving the hydrogen bonds between complementary bases. The deoxyribo nucleoside triphosphates are attracted from solution in the cellular sap to form hydrogen bonds with their complementary bases on the separated strands of the (primer RNA) template dictates the sequence in which the monomers are assembled.

Polymerisation

During this reaction, each incoming nucleotide loses a pyrophosphate group and forms an ester linkage with the 3' hydroxyl group of the deoxyribose on the existing last nucleotide. This linkage is called “phosphodiester linkage”.

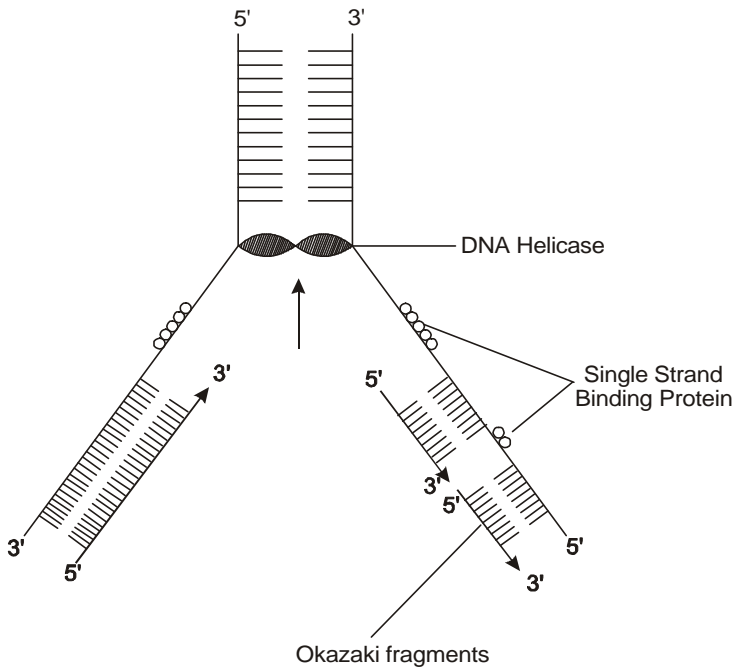

Fig. 6.6 Diagram of Replication Fork

The parental strands run in antiparallel direction. Synthesis occur simultaneously on both strands, but at different rates. No enzymes can synthesize $3' \rightarrow 5'$ direction and a single enzyme can not synthesize both strands. The single enzyme replicates one strand called leading strand in a continuous manner in $5'$ to $3'$ direction (forward), it replicates the other strand, lagging strand in a discontinuous manner and polymerising only few (250) nucleotides again run in $5'$ to $3'$ at backward direction. This is called semicontinuous DNA synthesis. The newly synthesized DNA is made as discontinuous small fragments called as Okazaki fragments and joined by the enzyme called ligase.

Thus 2 daughter double helices are formed each consisting of an old strand of the primer DNA and a complementary new strand. The final composition and nucleotide sequence of each strand is identical with the

corresponding strand in the template (parent) DNA. This process has been named as replication.

6.2 Catabolism of DNA by Deoxyribonucleases

The nucleic acids exist mainly in the nucleus as nucleoproteins. These nucleoproteins in the diet are degraded by HCl to nucleic acids and proteins.

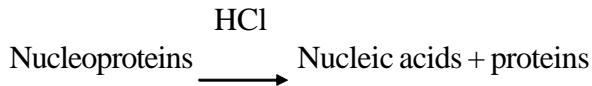

Nucleic acids pass as such from the stomach and their catabolism starts in duodenum by several enzymes (nucleases, nucleotidases and nucleosidases) which degrade the nucleic acids to purines, pyrimidines and pentoses. Three different types of enzymes which degrade the nucleic acids are discussed one by one.

Nucleases

The enzymes which degrade the nucleic acids are known as nucleases. Some are specific for RNA and thus known as ribonucleases, and others for DNA and thus known as dexoyribonucleases, while still some others are capable of attacking DNA as well as RNA.

Deoxyribonucleases are further classified in to 2 categories.

1. **Exonucleases** are the nucleases that attack only the internucleotide bonds located at the ends of the nucleic acid.

Exonucleases are further classified into 2 groups.

- (i) Those, which attack the 3' end of single strand DNA called 3' exonuclease
- (ii) Those, which attack the 5' end of the single strand DNA called 5' exonuclease

These 2 enzymes are non specifically called as phosphodiesterases.

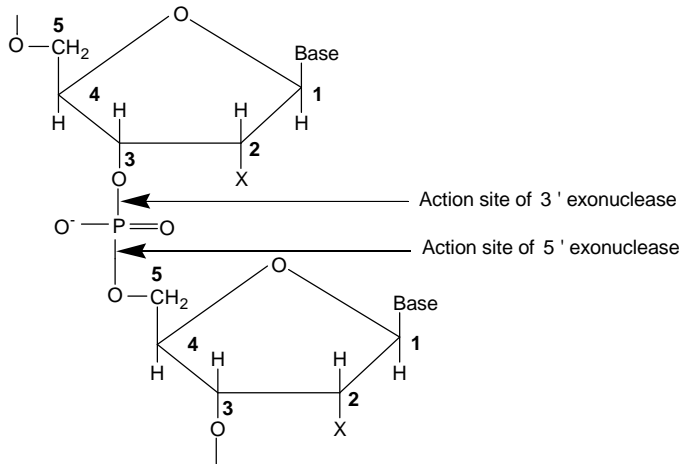
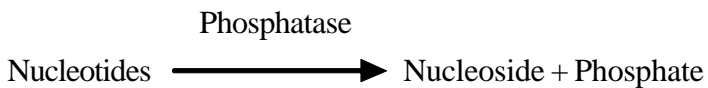

Fig. 6.7 Sites of action of exonucleases

- 2. Endonucleases** are the nucleases that attack only the internucleotide bonds located throughout the length of the nucleic acid chain (in the middle).

Nucleotidases (Phosphatases)

These enzymes hydrolyse the nucleotides to the corresponding nucleosides and inorganic phosphate molecules.



Nucleosidases (Nucleoside phosphorylase)

The nucleosides obtained above either absorbed or degraded into bases and sugars by nucleosidases.

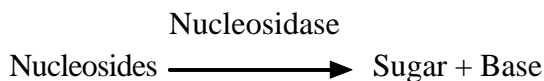

6.3 Biosynthesis of RNA (Transcription)

The biosynthesis of RNA is very much similar to that of DNA, except that in RNA it is differed by having different RNA types (mRNA, tRNA, rRNA), and the nitrogen base uracil instead of thymine. Like DNA, polymerization of 4 nucleoside triphosphates (viz ATP, CTP, GTP and UTP) in the presence of Mg^{2+} (or) Mn^{2+} ion is catalysed by the enzyme RNA polymerase and one strand of DNA serves as template.

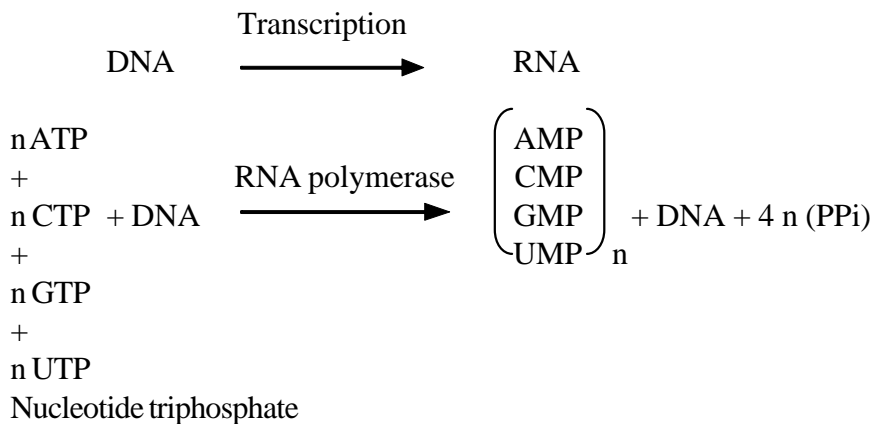

Mechanism

Transcription involves 3 stages

- i) Initiation
- ii) Elongation
- iii) Termination

Three phases of transcription

1. Initiation

In *E. coli*, all genes are transcribed by a single large RNA polymerase. This complex enzyme, called the holoenzyme is needed to initiate transcription since the σ factor is essential for recognition of the promoter. It is common for prokaryotes to have several σ factors that recognize different types of promoter (in *E. coli*, the most common σ factor is σ^{70}).

The holoenzyme binds to a promoter region about 40-60 bp in size and then initiates transcription a short distance downstream (i.e. 3' to the promoter). Within the promoter lie two 6 bp sequences that are particularly important for promoter function and which are therefore highly conserved between species. Using the convention of calling the first nucleotide of a transcribed sequence as +1, these 2 promoter elements lie at position -10 and -35, that is about 10 and 35 bp respectively, downstream of where transcription will begin.

2. Elongation

After transcription initiation, the σ factor is released from the transcriptional complex to leave the core enzyme ($\alpha, \beta, \beta', \omega$) which continues elongation of the RNA transcript. Thus, the core enzyme contains the catalytic site for polymerisation, probably within the subunit. The first nucleotide in the RNA transcript is usually PPPG (or) PPPA. The RNA polymerase then synthesises the RNA in the 5' \rightarrow 3' direction, using the 4 ribonucleotide 5' triphosphates (ATP, CTP, GTP, UTP), as precursors.

The 3'-OH group at the end of the growing RNA chain attaches to a phosphate group of the incoming ribonucleotide 5' triphosphate to

form a 3',5' phosphodiester bond (figure 6.8). The complex of RNA polymerase, DNA template and new RNA transcript is called a ternary complex (i.e three components) and the region of unwound DNA that is undergoing transcription is called transcription bubble (figure 6.9). The RNA transcript forms a transient RNA-DNA hybrid helix with its template strand but then peels away from the DNA as transcription proceeds. The DNA is unwound ahead of the transcription bubble and after the transcription complex has passed, the DNA rewinds.

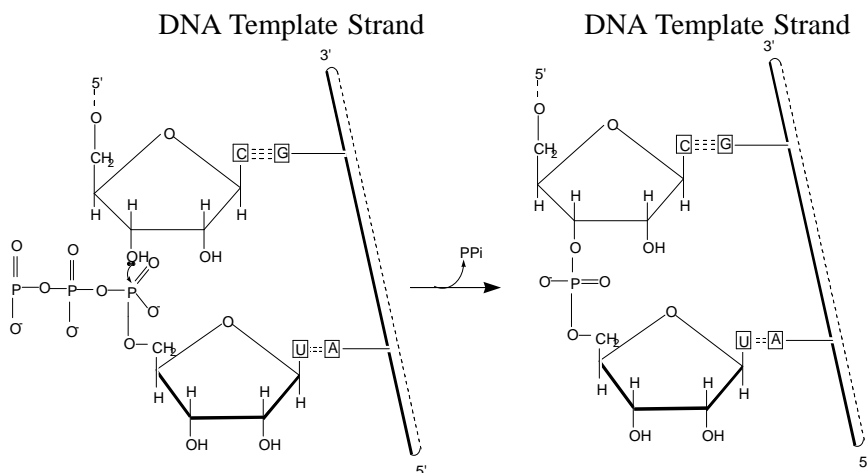

Fig. 6.8 Transcription by RNA polymerase

In each step the incoming ribonucleotide selected is that which can base pair with the next base of the DNA template strand. In the diagram, the incoming nucleotide is UTP to base pair with the A residue of the template DNA. A 3',5' phosphodiester bond is formed, extending the RNA chain by one nucleotide, and pyrophosphate is released. Overall the RNA molecule is grown in a 5' to 3' direction.

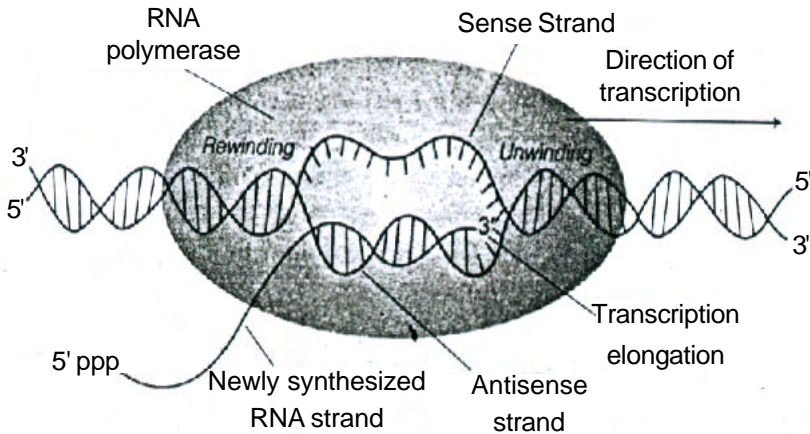

Fig. 6.9 A transcription bubble

The DNA double helix is unwound and RNA polymerase then synthesizes an RNA copy of the DNA template strand. The nascent RNA transiently forms an RNA-DNA hybrid helix but then peels away from the DNA which is subsequently rewound into a helix once more.

3. Termination

Transcription continues until a termination sequence is reached. The most common termination signal is a G ≡ C rich region is a palindrome, followed by an A = T rich sequence. The RNA made from the DNA palindrome is self complementary and so base pairs internally to form a hairpin structure rich in GC base pairs followed by four or more U residues (fig.6.10). However not all termination sites base this hairpin structure. Those that lack such a structure require an additional protein, called rho protein (ρ) to help recognize the termination site and stop transcription.

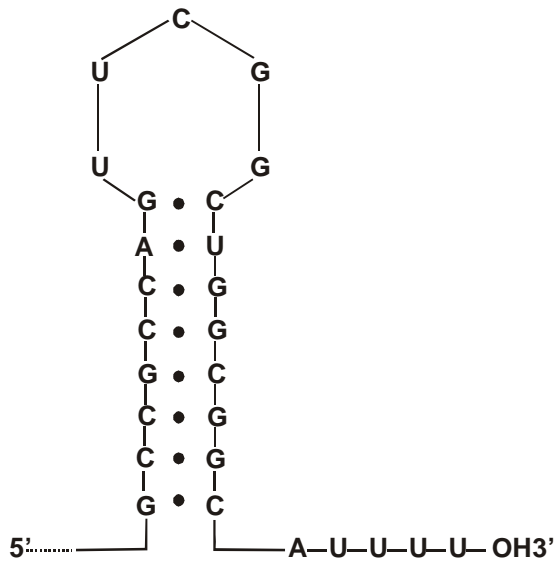

Fig. 6.10 A typical hairpin structure formed by the 3' end of the RNA molecule during termination of transcription

Post Transcriptional Modification

Post-transcriptional modifications are not needed for prokaryotic mRNAs. The formation of functionally active RNA molecule continues after transcription is completed in eukaryotes. The product of transcription in eukaryotes are called as primary transcripts and they undergo modification by a process called post transcriptional modification.

6.3.1 Processing of mRNA molecules

mRNA undergoes several modifications before it is being translated. They are

1. Addition of blocks of poly A, containing 200 (or) more AMP residues to the 3' end of messenger RNAs. This addition of poly A tail takes place in the nucleus.

2. A methylated Guanine nucleotide called as “5' cap” is added to the 5' end of mRNA molecule.
3. Methylation occurs in the internal adenylate nucleotides at their N-6 position. It's function is not known.

Thus mRNA is processed to get the active mRNA molecule.



6.3.2 Processing of tRNA Molecules

Most cells have 40 to 50 distinct tRNAs. Transfer RNA's are derived from longer RNA precursors of enzymatic removal of extranucleotide units from the 5' and 3' ends.

1. Formation of the 3'-OH terminus

This process involves the action of an endonuclease that recognizes a hairpin loop at the 3' end called RNase D, which stops two bases at short of CCA terminus, though it later removes these two bases after the 5' end is processed. This enzymatic digestion leaves the molecule called pre-tRNA.

2. Formation of the 5'-P terminus

The 5'-P terminus is formed by an enzyme called RNase P, which removes excess RNA from the 5' end of a precursor molecule by an endonucleolytic cleavage that generates the correct 5' end.

3. Production of modified bases

The final modification is to produce the altered bases in the tRNA.

In tRNA, two uridines are converted to pseudo uridine (ψ), one guanosine to methyl guanosine (MG), one adenine to isopentyladenine (IPA) etc.

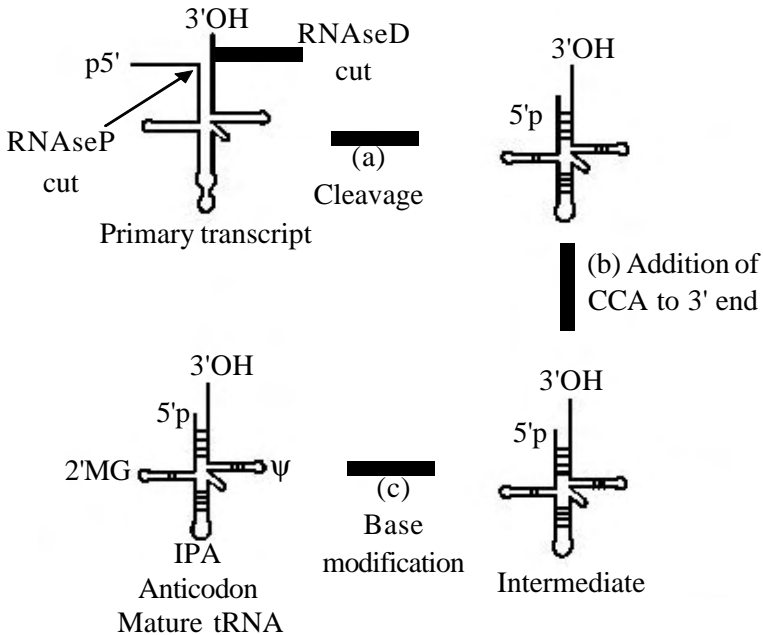

Fig. 6.11 Modification of tRNA molecules

Role of tRNA in protein synthesis

Transfer RNA is the smallest polymeric RNA. These molecules seem to be generated by the nuclear processing of a precursor molecule.

The tRNA molecules serve a number of functions, the most important of which is to activate amino acids for protein synthesis. The function of tRNA is to bind the specific amino acids, one might think that there are 20 types of tRNAs (i.e. as many as the constituent amino acids of proteins). Since the code is degenerate (i.e. there is more than one codon for an amino acid). There are also more than one tRNA for a specific

aminoacid. Therefore there are generally several tRNAs specific for the same aminoacid (Sometimes upto 4 or 5); they are called isoacceptor tRNA's. These various tRNA's, capable of binding the same amino acid, differ in their nucleotide sequence, they can either have the same anticodon and therefore recognize the same codon (or) have different anticodons and thus permit the incorporation of the aminoacid in response to multiple codons specifying the same aminoacid.

As mentioned, each tRNA is specific for an aminoacid i.e. it can bind (or accept) only that particular aminoacid. Thus, tRNA^{Ala} denotes a tRNA specific for alanine.

Codon is made up of 3 bases, and is present in mRNA. The tRNA contains anticodon which is complementary (opposite) to codons in mRNA.

Table 6.1 The differences between replication and transcription

Sl. No.	Replication	Transcription
1.	Monomer possesses 2-deoxy ribose moiety	Monomer possesses ribose moiety
2.	Product formed is double stranded DNA	Product formed is single stranded RNA
3.	RNA primer is essential	RNA primer is not required
4.	Both the strands act as a template	Only one strand act as a template
5.	The enzyme involved is DNA polymerase	The enzyme involved is RNA polymerase
6.	DNA template altered	DNA template unaltered

Excercises

I. Choose the correct answer from the alternatives

- a. The divalent cation needed for the catalysis of DNA synthesis is
i) Calcium ii) Magnesium iii) Phosphate iv) Chloride
- b. Okasaki fragments are present in
i) both the parental strands ii) both the daughter strands
iii) leading strand iv) lagging strand
- c. G-C rich region followed by A-T rich region is a signal for
i) initiation ii) elongation iii) termination iv) primer formation
- d. One among the following is not a modified base
i) pseudo uridine ii) isopentyl adenine
iii) methyl guanosine iv) deoxy thymine
- e. Methyl cap and poly A tail are present in
i) mRNA ii) tRNA iii) rRNA iv) hnRNA

II. Fill up the blanks

1. _____ is needed for the synthesis of DNA from the template.
2. Post transcriptional modification involves production of modified bases like _____
3. Adenine will pair with _____ in RNA.
4. Four Nucleoside _____ are needed to synthesize DNA and RNA
5. _____ catalyses the synthesis of RNA primer.

III. Say true or False

1. TTP is needed for the synthesis of RNA.
2. Okasaki fragments are joined by helicases.
3. Single strand binding proteins bind to double stranded DNA
4. Sigma factor of RNA polymerase recognized different promoters in *E. coli*.
5. tRNA molecules are not processed.

IV. Match the following

- | | | |
|------------------|---|------------------|
| 1. DNA | - | mRNA |
| 2. Replication | - | deoxy ribose |
| 3. Transcription | - | tRNA |
| 4. Anticodon | - | synthesis of DNA |
| 5. Codon | - | synthesis of RNA |

V. Give one word answer

1. What enzyme is involved in joining Okasaki fragments?
2. What are the modified bases present in RNA?
3. Name the enzyme that catalyses the formation of RNA primer.
4. Name the base that is unique to DNA.
5. Which protein is involved in termination of transcription?

VI. Answer the following briefly

1. Give an account on catabolism of nucleic acids.
2. Briefly discuss the various steps involved in DNA biosynthesis.
3. List the post transcriptional modifications that occur to RNA.
4. Give an account on transcription
5. What is the role of tRNA in protein synthesis?

CHAPTER VII

Inborn Errors of Metabolism

Introduction

The term inborn errors of metabolism was coined by Garrod in 1908 for four rare hereditary diseases; albinism, alkaptonuria, cystinuria and pentosuria. Such diseases occur even during birth and thus are inherited. Inherited errors of metabolism lead to inherited diseases.

The metabolism of our body comprises two major balanced activities: anabolism (synthesis) and catabolism (degradation). Whether the metabolic changes are exergonic or endergonic, most of them have to be catalysed by enzymes. If one particular enzyme is deficient or absent then that leads to a block in the pathway of biochemical reactions leading to metabolic abnormalities which are present throughout the life and handed over to the progeny.

The absence or deficiency of an enzyme will cause an abnormal accumulation of the intermediate products of metabolism in the body and increased excretion in urine as such or their degradation products. Some of the intermediates could even be toxic.

For example, in the following reaction,



R is the reactant, B, C and D are intermediates and P is the product and a, b, c and d are enzymes catalyzing various steps of the reactions. In this reaction pathway, if any one of the enzyme is deficient or absent, the previous intermediate accumulates and produces toxicity. It also affects the amount of product (P) formation which may be essential biologically and there by leads to pathological diseases.

An enzyme usually controls one step in a sequence of reactions. Beadle and Tatum put forth their theory of one gene one enzyme hypothesis which states that one gene controls the synthesis of a single enzyme. It is also known that enzymes are being proteins, whose synthesis is governed by the DNA and aberrations of the enzyme protein will be definitely brought about by mutations in the DNA. Thus, diseases due to absence or deficiency of enzymes are due to defective genes in DNA. Hence, these hereditary or congenital diseases cannot be cured. The defective gene may be present in the autosomal chromosomes or in the sex chromosomes.

Galactosemia, Von-Gierke's disease, hemophilia, albinism, alkaptonuria and Tay-Sach's disease are some of the important diseases due to inborn errors of metabolism.

7.1 Galactosemia

It is an inherited disorder, in which there is inability to convert galactose to glucose in a normal manner. The incidence of this disease is about 1 in 18,000 live births.

7.1.1 Causes

Enzyme deficiency in galactose metabolic pathway causes galactosemia. The pathway for conversion of galactose to glucose is shown in figure 7.1.

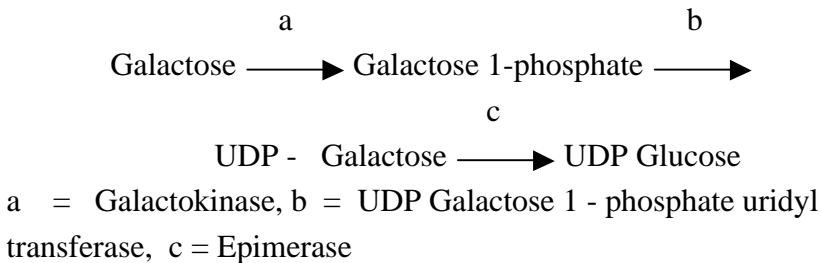

Fig. 7.1 Metabolism of Galactose

In galactosemia, there is inability to metabolize galactose which may be caused by the enzyme deficiency of a = galactokinase, b = UDP Galactose 1 - phosphate uridyl transferase.

7.1.2 Symptoms

The deficiency of galactose 1 - phosphate uridyl transferase is clinically important. Due to the enzyme defect galactose accumulates in blood and is reduced by aldose reductase in the eye to the corresponding galactitol which causes cataract.

The general condition is more severe if it is due to a defect in galactose 1 - phosphate uridyl transferase, since galactose 1- phosphate accumulates and depletes the liver of inorganic phosphate. Ultimately, liver failure and mental deterioration results.

Infants appear normal at birth but later they show failure to thrive and become lethargic. They have frequent vomiting and hypoglycemia. After 2 - 3 months of age the liver may show fatty infiltration and lead to cirrhosis (non functioning of liver cells). Galactosemia at this age is associated with mental retardation due to accumulation of galactose and galactose 1 - phosphate in cerebral cortex. So, the galactosemic child fails to grow and suffer from liver damage and mental retardation.

7.2 Von - Gierke's Disease

This is one of the groups of rare genetic disorder due to the defect in one or more of the enzymes involved in glycogen metabolism leading to excessive accumulation of glycogen in the tissue especially in liver, muscle and heart.

The first glycogen storage disease identified was Von-Gierke's disease. The frequency of this disease is one in two lakhs.

7.2.1 Cause

This was the first inherited deficiency identified to affect liver. In this, the enzyme which is deficient is glucose 6-phosphatase that converts glycogen to glucose 6-phosphate and then to glucose.

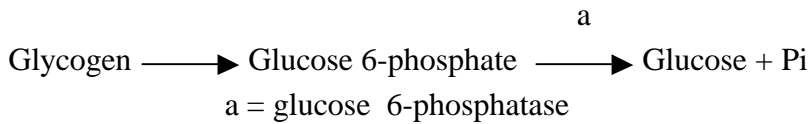

Fig. 7.2 Conversion of glycogen to glucose

7.2.2 Symptoms

Both liver cells and the cells of renal convoluted tubules are loaded with glycogen. Ketosis and hyperlipidemia are also present. Glycogen content in the liver can rise to 15 per cent. Glycogen accumulates in kidney also. Massive enlargement of the liver, pronounced hypoglycemia in between meals, failure of blood glucose to rise on administration of glycogen and convulsion are seen in this condition. Since glucose 6-phosphate cannot leave liver cells, there is compensatory increase in glycolysis leading to increased levels of pyruvic acid and lactic acid. The only treatment available is frequent feeding to avoid hypoglycemia in Von-Gierke's Disease.

7.3 Hemophilia

The process of blood coagulation is a vital mechanism of defence against excessive loss of blood. There are nearly 13 factors involved in the mechanism of blood clotting. If any one or more of these factors are not synthesised adequately and properly that results in defect in blood clotting and thereby hemorrhage.

A number of inherited deficiency of the blood clotting factors are found in human and are collectively called as hemophilias.

Causes

Hemophilia is an inherited disease, where clotting occurs at an abnormally slow rate due to the absence of one or more of the blood clotting factors. The sufferers are known as 'hemophiliacs' or 'bleeders'. It is peculiar that it affects only males. The most common deficiency is that deficiency of the factor VIII, causes hemophilia A. Deficiency of factor IX causes hemophilia B. Deficiency of factor XI causes hemophilia C.

Symptoms

The characteristic findings of this disease are:

- Bleeding which does not stop. These individuals should be extremely careful not to contract even minor injuries like trauma or extraction of tooth, since this may result in severe hemorrhage (blood loss).
- Marked prolongation of the coagulation time of the blood, while prothrombin time being normal.

7.4 Albinism

It includes a spectrum of clinical syndromes characterized by hypomelanosis i.e., reduced synthesis of melanin pigment in skin and eyes. The defect is in the enzyme tyrosinase which is responsible for the biosynthesis of the pigment and hence the individual appears bleached. In this condition, melanin is not synthesized in the melanocytes and affects the skin, hair, sclera and choroids etc. Melanin is synthesized from tyrosine as shown in the figure 7.3.

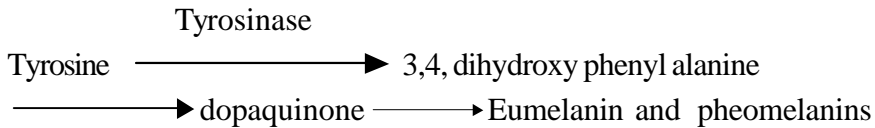

Fig. 7.3 Synthesis of melanin from tyrosine

Generally, two types of albinism is seen ; a) Oculo-cutaneous albinism. In this type, there is decreased pigmentation of skin and eyes, b) Ocular albinism. In this type, there is decreased pigmentation of only eyes and not the skin.

7.5 Alkaptonuria

This is a rare inborn error of metabolism of phenylalanine and tyrosine. Estimated incident is 2-5 per million live births.

Cause

The disease is characterised by the deficiency of homogentisate oxidase which catalyses the conversion of tyrosine to acetyl coA and acetate. In this reaction sequence homogentisic acid (homogentisate) is an intermediate which is oxidised by the enzyme homogentisate oxidase. This results in the accumulation of homogentisic acid as shown in the figure 7.4.

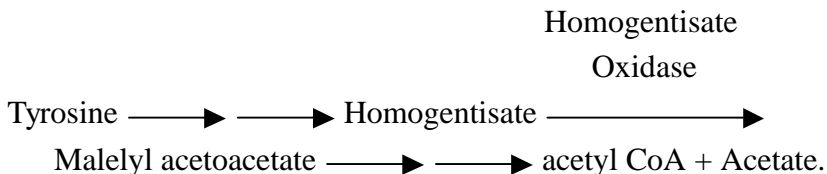

Fig. 7.4 Role of homogentisate oxidase in tyrosine catabolism

Symptoms

Homogentisic acid accumulates in the tissues and blood and also appears in urine. Most striking clinical manifestation is occurrence of dark urine on standing in air. Homogentisic acid like many derivatives of tyrosine is readily oxidized to black pigments. These pigments are called as alkaptons. Urine in an exposed air slowly turns black from top to bottom.

In long standing cases, deposition of homogentisic acid derivatives in cartilages of ears and other exposed places leading to generalized pigmentation of connective tissues and deposition in joints leading to arthritis, a condition is called ochronosis. This is due to the oxidation of homogentisate by polyphenol oxidase, forming benzoquinone acetate, which polymerizes and binds to connective tissue macromolecules.

7.6 Taylach's Disease

Gangliosides are glycosphingolipids which are present in small amounts in the membranes of a wide variety of tissues. Nervous tissues are particularly rich in gangliosides. Generally, the carbohydrate segments of glycolipids are removed by lysosomal hydrolases in the early phases of the turn over of these compounds. Several inborn errors due to the deficiency of these hydrolases have been well documented.

Gangliosides are synthesized from sphingosine as follows:

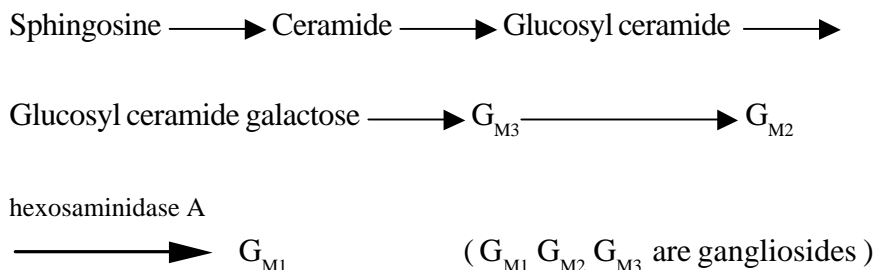

Cause

Taysach's disease is due to the absence of N-acetyl hexosaminidase A that leads to the accumulation G_{M2} in brain and spleen. Hence the ganglioside G_{M2} is called as Taysach's ganglioside.

In this condition G_{M2} is not degraded to G_{M1} and accumulates in large amounts in lysosomes, particularly in the brain cells. The amount sometimes exceeds 100 - 300 times the normal content causing degeneration of the nervous system.

Symptoms

Muscle weakness, retardation in development and difficulty in eating are typical early symptoms.

Mental retardation and blindness are the characteristic symptoms in this rare genetic disorder. Death between 2 -5 years is unavoidable. More than 90 % of the patients have a characteristic cherry red spot in the retina.

Taysach's disease can be diagnosed by taking amniotic fluid from the mother and assaying the hexosaminidase A activity.

7.7 Neoplasm

Cancer is the second most common cause of death in the world after cardiovascular diseases. Human of all ages develop cancer and wide variety of organs are affected.

Cancer cells are characterized by three properties: 1) diminished or unrestrained control of growth and cell division; 2) invasion of local tissue; and 3) spread or metastasis to other parts of the body. Cell growth and cell division are regulated by finely tuned control mechanisms. When these processes lose their control, a cell begins to grow uncontrollably. The result is the formation of a mass of cells called a tumour. The overall processes is called neoplasm.

The primary event in neoplasm appears to be the alteration in DNA . Most of the tumours are localized without spread and so without risk to the host, they are called benign tumours. Sometimes they start interfering with normal tissues and secreting excessive amount of some hormones or other biologically active substances. These substances are called as tumour markers.

Changes in the levels of tumour markers in serum are useful in detecting tumours and cancers. Increase in Ca^{++} level is seen in multiple myeloma and bone cancer. Elevated levels of alkaline phosphatase is observed in malignancy of bone, liver and carcinoma of bronchus.

Tumours become life threatening , when their cells instead of being localized spread throught the body. They become malignant and cause cancer. These cells can spread and invade surrounding

tissues or can travel through the blood stream. Development of secondary areas of growth away from the original site of growth is called metastases. Changes in growth properties of cells and their subsequent ability to form malignant tumours are collectively referred to as transformation.

Cancers are classified according to the tissue and cell type from which they originate. Those arising from epithelial cells are called carcinomas. Those arising from connective tissue or muscle cells are called sarcomas. Cancers that do not fit into either of these broad categories include leukemias, lymphomas and cancer of the cells of central nervous system. Nearly 90% of human cancers are carcinomas

Causes of cancer

Agents causing cancer fall into 3 categories: a) radiant energy, b) chemical compounds and c) viruses.

a) Radiant energy: Ultraviolet rays, X-rays and γ -rays are mutagenic and carcinogenic. These rays damage DNA which is presumed to be the basic mechanism of carcinogenicity.

Apart from direct effects on DNA, X-rays and gamma rays cause free radicals to form in tissues which may act as carcinogens.

b) Chemical compounds: A wide variety of organic and inorganic molecules may be carcinogenic.

Examples of organic carcinogens are Benzopyrene, Dimethylbenzanthracene, Dimethylnitrosamine and AflatoxinB₁.

Examples of inorganic carcinogens are arsenic, asbestos, beryllium, cadmium and chromium.

Very few carcinogens interact with DNA directly without further metabolism. These carcinogens are called as direct carcinogens. But many of the carcinogens need prior metabolic activation and the activated ultimate carcinogen can interact with DNA. The ultimate carcinogens are usually electrophiles which readily attack nucleophilic groups in DNA, RNA and proteins.

c) **Viruses:** Viruses that contain either DNA or RNA as their genome which induce cancer are called as oncogenic viruses. For example Epstein - Barr virus cause Burkitt's lymphoma and nasopharyngeal carcinoma and Herpes simplex virus cause cancer in the cervix in humans.

7.7.1 Biochemical changes found in tumour cells

The following changes are found in tumour cells

- i. Increased synthesis of RNA and DNA.
- ii. Decreased catabolism of pyrimidines
- iii. Increased rates of aerobic and anaerobic glycolysis.

Some changes that have been detected at the surface of malignant cells are alteration in transport properties, permeability, surface charge, diminished adhesion, appearance of new antigens,

changes of glycolipid constituents and alterations of the oligosaccharide chains of glycoproteins.

Exercises

I. Choose the correct answer from the given four alternatives

1. The metabolite that accumulates in Tay Sachs disease is
i) galactose ii) tyrosine iii) ganglioside iv) glucose
2. Deficiency of glucose 6-phosphatase is seen in
i) Von Gierks disease ii) galactosemia
iii) albinism iv) alkaptonuria
3. Liver cells are loaded with glycogen in
i) hemophilia ii) galactosemia
iii) albinism iv) Von-Gierkes disease
4. Hypopigmentation in skin and sclera is observed in
i) albinism ii) alkaptonuria
iii) hemophilia iv) galactosemia.
5. Abnormal proliferation of cells is seen in
i) neoplasm ii) albinism iii) alkaptonuria iv) hemophilia

II. Fill in the blanks

1. Metabolism comprises of anabolism and _____
2. The enzyme deficiency in albinism is _____
3. Hemophilia A is caused by deficient of _____ factor. _____

4. In alkaptonuria, deficiency of _____ is observed.
5. Carcinogens are chemicals which cause _____

III. Say true or false

1. Benign tumours cannot spread from one part of the body to another
2. Galactosemia affects liver
3. Blood clotting mechanism is affected in hemophilia
4. Alkaptonuria is associated with hypopigmentation of skin
5. Oncogenic virus can induce cancer

IV. Match the following

- | | | |
|---------------------------|---|---|
| 1. Galactosemia | - | Hexosaminidase A |
| 2. Von - Gierke's disease | - | Tumour |
| 3. Neoplasm | - | Galactose 1 - phosphate
uridyl transferase |
| 4. Tay sach's disease | - | Tyrosinase |
| 5. Albinism | - | Glucose 1 - phosphatase |

V. Answer the following

1. What is an inborn error of metabolism ?
2. Give the cause and the symptom of albinism
3. Explain the pathology of galactosemia
4. What are the characteristic features of cancer cells ?
5. What are the causes of cancer ?

CHAPTER VIII

Biological Oxidation

Introduction

The oxidative degradation of carbohydrates, fats and amino acids at cellular level needs oxygen and any metabolism after complete oxidation forms CO_2 and H_2O . Hence, any biological oxidation taking place at tissue level is associated with the uptake of oxygen and release of carbon dioxide and rapidly liberates energy. This biological oxidation accompanied by specific enzymes and coenzymes in a step wise fashion involves the union between hydrogen atoms with oxygen atom to form water. During the electron transport, the electrons are transferred from organic substrates to oxygen yielding energy in the generation bond energy in the form of Adenosine triphosphates (ATP) from Adenosine diphosphates (ADP). ATP and ADP are known as high energy phosphates as the cleavage of phosphate bond in them yield energy and inorganic phosphate. This energy is utilized for the anabolic and catabolic processes. The oxidative phosphorylation enables the aerobic living organisms to capture a far greater proportion of available free energy of the oxidizing substrates in the form of ATP. Oxidation involving phosphorylation is a very vital process and it is a continuous process and any disturbance of its function is incompatible with life.

8.1 Redox Couple

Always every *oxidation is accompanied by a reduction process*. All such reactions are termed as *oxidation-reduction reactions* and shortly referred as *redox*. These redox reactions are associated with movements of electron. The electron donor is called as reductant or reducing agent and the electron acceptor, the oxidant or oxidizing agent. The system which transfer its electron is changed into oxidant form while the system which accepts electrons gets converted to the reductant form. Oxidation reduction system is simplified and shown below (fig 8.1)

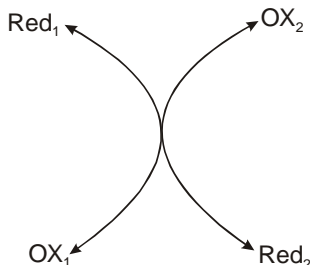
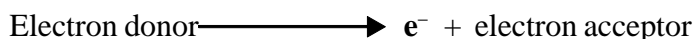
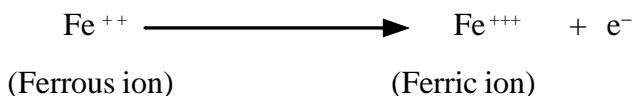

Fig. 8.1 Oxidation-Reduction System



A specific example is oxidation of ferrous iron to ferric iron indicates the removal of electron (e^-) from ferrous iron.



Since, the electron is not stable in the free form it gets attached to another molecule and thus every oxidation is followed by a reduction. Always these redox reactions are energy yielding. A direct transfer of electrons from substrate to the oxidant would liberate a sudden burst of energy and most of it will be wasted by dissipation. Normally when the electrons of hydrogen combine with oxygen results in explosion. In biological system this oxidation reduction process takes place smoothly

without increasing the temperature because the transfer of hydrogen pairs occurs in a step by step process till it reacts with oxygen. This permits the liberation of energy in small amounts so that it can be captured and saved.

8.1.1 Redox Potential

In oxidation and reduction reactions the free energy exchange is proportionate to the tendency of reactants to donate or to accept electrons. The affinity for the electron by the oxidant is called the electron affinity or redox potential. In biochemistry, the oxygen has the highest redox potential or electron affinity (E_0) and therefore the electron pass from the systems of hydrogen donors which have lower potentials. It is usual to compare the redox potential of a system (E_0) against the potential of the hydrogen electrode, which is at pH 0 designated as 0.0 volts. However, in a biological system it is normal to express the redox potential (E_0) at pH 7.0 at which the electrode potential of hydrogen electrode is - 0.42volts. In the biological system, the enzymes concerned with this oxidation reduction processes are designated as oxidoreductases. Some of the redox potentials are given in the table 8.1.

Table 8.1 Some of the redox potential of special interest

System	E_0 (volts)
H^+ / H_2	- 0.42
Oxygen /water	+ 0.82
Cytochrome a Fe^{3+} / Fe^{2+}	+ 0.29
Cytochrome b Fe^{3+} / Fe^{2+}	+ 0.08
Cytochrome c Fe^{3+} / Fe^{2+}	+ 0.22
$NAD^+ / NADH+H^+$	- 0.32

A positive value for the standard reduction potential means that a compound in question preferentially is reduced when involved in a redox reaction with hydrogen. A negative value means that a compound in question is preferentially oxidized. However, listings of standard reduction potentials are always given in the form of a reduction reaction.

8.2 Electron transport chain

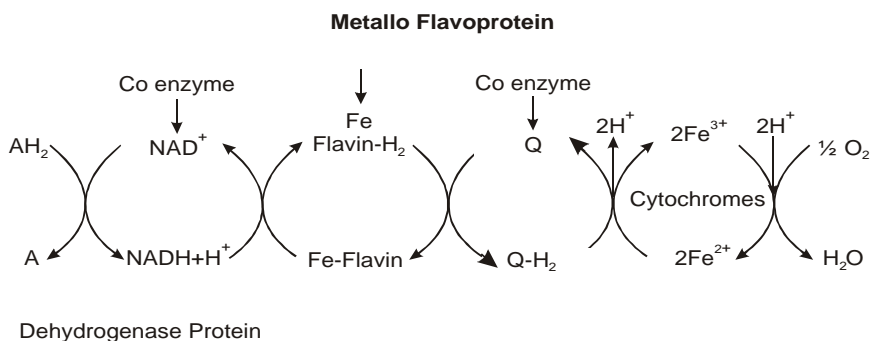

Fig 8.2 Electron Transport Chain

The electron transport chain (figure 8.2) consists of series of proteins which tightly bound involves the passage of a pair of electrons from one chemical to the next, whereby each chemical in the sequence has less reduced energy than the previous. The electron transport chain oxidizes (i.e. “burns”) the $NADH+H^+$ and $FADH_2$ cofactors, using molecular oxygen as the final electron acceptor. In the electron transport chain electron carriers and hydrogen-electron acceptors are positioned alternatively to carry the function. There are three different regions in the electron transport chain, where energy is released. In each region there is a formation of one ATP. All these reactions and capturing of energy takes place in mitochondria.

8.2.1 Components of mitochondria with marker enzymes

The histochemical and ultra centrifugation studies clearly established that the major site of cellular oxidation is mitochondria. These are sub cellular organelles and quite vary in size and shape. Ellipsoidal, spherical or rod shaped structures measuring about 0.5-5 μ in length and 0.1-0.6 μ in width. Since, the energy released in the oxidation process is converted into chemical energy (ATP). Mitochondria otherwise called as **power house** of the cell. Hence the number of mitochondria in a cell depends on it's metabolic activity. All the reducing equivalence that can release energy during oxidation of carbohydrates, fatty acids and proteins are available in the mitochondria. In mitochondria, a series of catalysts referred as respiratory chain that collects these reducing equivalents and direct them towards oxygen to form water.

The electron microscopic picture of the mitochondria shows a double membrane, an **outer and inner membrane** which consists of different specific enzymes. The folding of the inner membrane produces a number of partitions called **cristae** that extend into the matrix. The inner membrane encloses the matrix and it is very selective in its permeability. Inner membrane is highly complex in its structure and function. The space between the inner and the outer membrane is called as **Inter membrane space** which is surrounded by **matrix**. The mitochondria contains its own circular DNA and ribosomes. Some mitochondrial proteins are thus coded for and produced by the mitochondria itself. Other mitochondrial proteins are coded by nuclear DNA, synthesized by cytosolic ribosomes, and subsequently transported to the mitochondria.

The structure of mitochondria (figure 8.3) and the location of various essential enzymes are given in the form of diagram. Since these enzymes

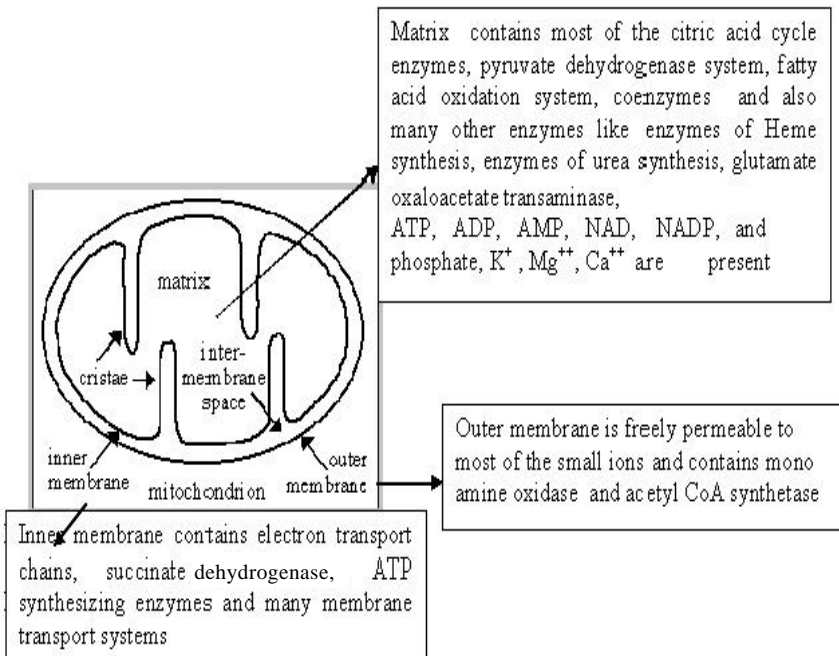

Fig. 8.3 Structure of Mitochondria

8.2.2 Members of the electron transport chain

The electron transport chain is initiated by the reaction of an organic metabolite (intermediate in metabolic reactions) with the coenzyme NAD^+ (nicotinamide adenine dinucleotide is a coenzyme containing the B-vitamin, nicotinamide). This is an oxidation reaction where 2 hydrogen atoms (or 2 hydrogen ions and 2 electrons) are removed from the organic metabolite. (The organic metabolites are usually from the citric acid cycle and the oxidation of fatty acids—details in following pages). The reaction can be represented simply where M = any metabolite.



Complex I - *NADH dehydrogenase*, also called NADH coenzyme Q reductase located in the inner mitochondrial membrane and also contains non heme iron atoms. These dehydrogenase enzyme does not react with oxygen instead an electron carrier is interposed between the metabolite and next member in the chain. These enzymes consist of a protein part and a non protein part which is a coenzyme. The co enzyme NAD^+ or NADP^+ are utilized as the prime carriers of hydrogen.

Complex II - *Coenzyme Q* (Q for Quinone) or cytochrome c reductase is a Ubiquinone. It is in the inner membrane in the free form or protein bound form. Coenzyme Q occupies the position between metalloflavoproteins and cytochrome in the chain. At the point of coenzyme the H^+ ion dissociate and go into solution, leaving the electrons to the cytochromes .

Complex III -Cytochrome c oxidase. Cytochromes are very similar to the structure of myoglobin or hemoglobin. The significant feature is the heme structure containing the iron (Fe) ions, initially in the +3 state and changed to the +2 state by the addition of an electron. Cytochrome molecules accept only the electron from each hydrogen, not the entire atom. The several types of cytochromes hold electrons at slightly different energy levels. Electrons are passed along from one cytochrome to the next in the chain, losing energy as they go. Finally, the last cytochrome in the chain, cytochrome a_3 , passes two electrons to molecular oxygen. . These cytochromes are proteins that carry a prosthetic group that has an embedded metal atom. The protein ‘steals’ the ability of the metal atom to accept and release electrons.

Complex IV - ATP synthase, also known as the F_0F_1 particle has two components F_0 and F_1

(F - indicates the factor). F_1 protruding into matrix from the inner membrane and F_0 embedded and extend across the inner membrane. The protruding F_1 is essential for the energy coupling to ATP molecule. Careful removal of this component (experimentally) leads to impairment in ATP production though the intact respiratory chain is present.

8.3.3 Reactions of electron transport

The electron acceptors in the electron transport chain include FMN, ubiquinone (coQ), and a group of closely related proteins called cytochromes. The figure 8.4 shows arrangement of the protein

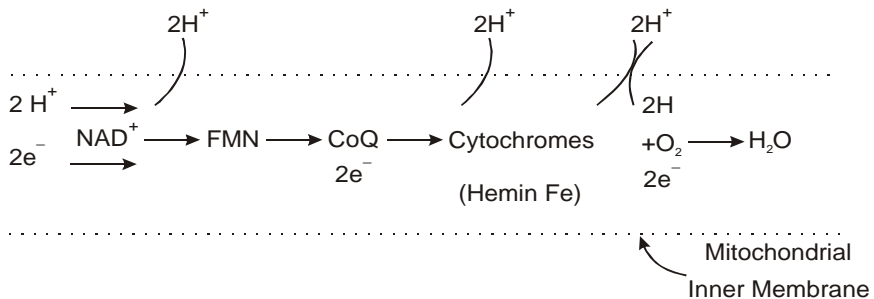
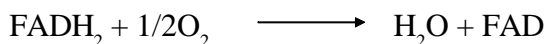
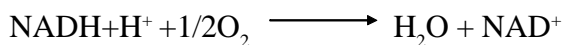

Fig. 8.4 Simplified Electron Transport

Oxidative Phosphorylation in Electron Transport Chain consist of the electron donors



The coupled oxidation/reduction reaction is



This coupled reactions yield free energy $\text{NADH}+\text{H}^+$ yields 52 Kcal/mole as the electrons from $\text{NADH}+\text{H}^+$ transfer to oxygen consist of three pumps yield 3 ATP molecule at 3 sites FADH_2 yields 36 Kcal/mole as the electron from FADH_2 transfer to oxygen there are two pumps yield 2 ATP molecule at 2 sites. The position at which the energy capture occurring as ATP are given in figure 8.5.

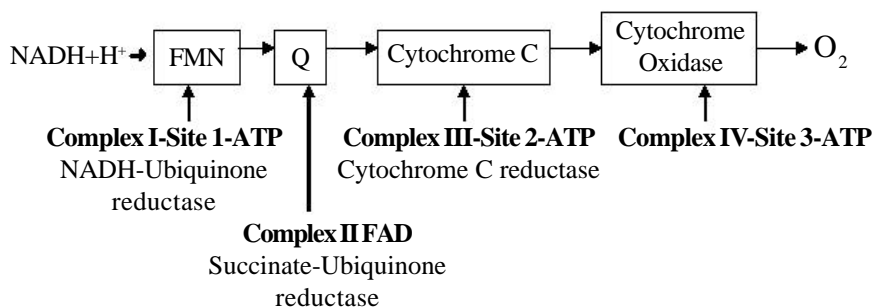

Fig.8.5 Arrangement of Proteins in Electron Transport Chain

Spontaneous flow of electrons through each of the respiratory chain complexes I, III, & IV is coupled to **ejection of H^+** from the mitochondrial matrix to inner membrane space. The ejection of proton gradient is done through inner membrane protein, **ATPase that uses released energy to drive the synthesis of ATP from ADP**. The terminal acceptor of electrons is molecular oxygen and it is reduced to water. However not all the energy released are captured as high energy phosphate bond and liberated as heat. In warm blooded animals this heat is used for the maintenance of body temperature. The important *respiratory control of electron transport chain is the availability of ADP*, the substrate for the ATP Synthase.

8.2.4 Inhibitors of electron transport chain:

The use of inhibitors gives much information about the electron transport chain. They are classified as (a) **inhibitors of respiratory chain**, (b) **inhibitors of oxidative phosphorylation**, and (c) **uncouplers of phosphorylation**.

- (a) **Inhibitors that arrest respiration** are barbiturates like amobarbital, antibiotic like piericidin A, antimycin A and fish poison rotenone. **The carbon monoxide and cyanide inhibit cytochrome oxidase** so that it cannot transport electrons to oxygen. This blocks the further passage of electrons through the chain, halting ATP production and life.
- (b) **Inhibitors of oxidative phosphorylation** are oligomycin and atcrtyloside.
- (c) **Uncouplers** dissolve in the membrane, and function as **carriers for H⁺ or it can be an ionophores**. Uncouplers block oxidative phosphorylation by dissipating the H⁺ electro chemical gradient by an un coupling the essential linkage between electron transport and ATP synthesis. Un couplers are 2,4 dinitro phenol, dinitrocresol, pentachlorophenol.

Ionophores (ion carriers) are lipid soluble substance capable of carrying specific ions through the membrane. They slightly differ in their action from the uncouplers as they also transport cation other than H⁺ through the membrane. Valinomycin forms a lipid complex through which the K⁺ ion readily pass through. The ionophore

gramicidin induces penetration to H^+ , K^+ or Na^+ and uncouples the oxidative phosphorylation.

8.3 Oxidative phosphorylation

Hydrogens or their electrons, pass down the electron transport chain in a series of redox reaction. The electrons entering the electron transport system have relatively high energy content. As they pass along the chain of electron acceptors, they lose much of their energy, some of which is used to pump the protons across the inner mitochondrial membrane. The flow of electrons in the electron transport is usually coupled tightly to the production of ATP with the help of the enzyme ATP synthetase, and it does not occur unless the phosphorylation of ADP can also proceed. This prevents a waste of energy, because high-energy electrons do not flow unless ATP can be produced. Because the phosphorylation of ADP to form ATP is coupled with the oxidation of electron transport components, this process of making ATP is referred to as oxidative phosphorylation. The electron transport and oxidative phosphorylation depends upon the availability of ADP and P_i and it is referred as acceptor control of respiration

8.3.1 Chemiosmotic theory

Peter Mitchell got the Nobel prize in 1978 for his theory of chemiosmosis. **The chemiosmotic theory of Mitchell claims that oxidation of components in respiratory chain generates hydrogen ion and ejected across the inner membrane.** The electrochemical potential difference resulting from the asymmetric distribution of the hydrogen ion is used as the driving force (potential energy). This consist of a **chemical concentration gradient of protons across the**

membrane (pH gradient) also provides a charge gradient. The inner mitochondrial membrane is impermeable to the passage of protons, which can flow back into the matrix of the mitochondrion only through special channels in the inner mitochondrial membrane. In these channels, the enzyme ATP synthetase is present. As the protons move down the energy gradient (**proton motive force = chemiosmotic energy**), the energy released is used by ATP synthetase to produce ATP.

The chemiosmotic model explains that this electrochemical potential difference across the membrane is used to drive a membrane located ATP synthetase which couple the energy to ADP, to form ATP. Protons are pumped across the inner mitochondrial membrane by three electron transfer complexes, each associated with particular steps in the electron transport system. As electrons are transferred along the acceptors in the electron transport chain, sufficient energy is released at three points to convey protons across the inner mitochondrial membrane and ultimately to synthesize ATP.

8.3.2 Role of $F_0 - F_1$ ATPase

ATP synthetase or $F_0 F_1$ ATPase, has two major components, F_0 and F_1 (F for factor). F_1 consists of 5 polypeptides, with stoichiometry **a, b, g, d, e**. The F_1 component resembles a doorknob protruding into the matrix from the inner membrane. It is attached to F_0 by a stalk, which is embedded in the inner membrane and extend across it. F_0 is a complex of integral membrane proteins. When F_1 is carefully extracted (from inside out vesicles prepared) from the inner mitochondrial membrane, the vesicles still contain intact respiratory chains. However, since it no longer contain the F_1 knobs, as confirmed by electron microscopy, they cannot make

ATP. When a preparation of isolated F_1 is added back to such depleted vesicles under appropriate conditions, to reconstitute the inner membrane structure, with F_1 knobs, the capacity of the inner membrane vesicles to carry out energy coupling between electron transport and ATP formation is restored. This shows the precise arrangement of these F_o and F_1 make the ATP synthetase to form complexes called respiratory assemblies. It is proposed that an irregularly shaped “**shaft**” linked to F_o was able to produce conformational changes as follows

1. A **loose** conformation in which the active site can loosely bind ADP + Pi
2. A **tight** conformation in which substrates are tightly bound and ATP is formed
3. An **open** conformation that favours ATP release.

As the protons move down the energy gradient, the energy released is used by ATP synthetase to produce ATP.

8.4 High energy compounds

The high energy compound is the ATP. The other high energy compounds include ADP, 1,3-diphospho glycerate, phosphoenol pyruvate and also creatine phosphate.

The phosphate group of the high energy phosphate may transfer directly to another organic compound. For this reason the term **group transfer potential** is preferred by some high energy bond. However, the phosphorylated compound may or may not have high energy phosphate

bond, though the total energy content of the molecule is higher than a non phosphorylated compound.

Storage form of high energy compounds

They are called as **phosphogens** and help to store the high energy. The example for this is the creatine phosphate present in the vertebrate muscles, the reaction works in both directions it is a reversible reaction form ATP when ATP is required. When ATP is more, creatine reacts with ATP and forms the phosphocreatine.

8.4.1 1,3-diphosphoglycerate

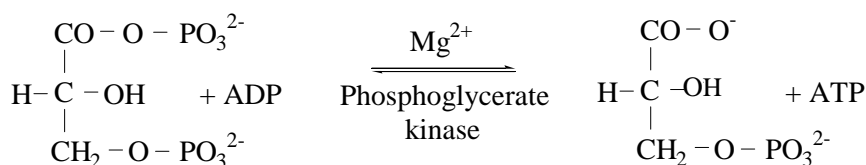

1,3-diphosphoglycerate

3-phosphoglycerate

One of the phosphate groups undergoes hydrolysis to form the acid and a phosphate ion, giving off energy. This first energy producing reaction is coupled with the next endothermic reaction making ATP. The phosphate is transferred directly to an ADP to make ATP and this is catalysed by phosphoglycerate Kinase enzyme. Since one molecule of glucose yield 2 molecule of Glyceraldehyde 3-phosphate, 2 high energy ATP are produced for one molecule of glucose.

Role of Phosphoenol pyruvate

Phosphoenol pyruvate, which is formed during breakdown of glucose to lactic acid, donates its phosphate group to ADP in a reaction catalyzed by Pyruvate kinase. One of the phosphate groups undergoes hydrolysis to form the acid and a phosphate ion, giving off energy. This first energy producing reaction is coupled with the next endothermic reaction making ATP. The phosphate can only exist as the high energy enol form. Thus, when the phosphate group is removed, the pyruvate can revert back to the stable, low-energy keto form and the surplus energy is released. Production of ATP in this reaction is controlled by pyruvate kinase

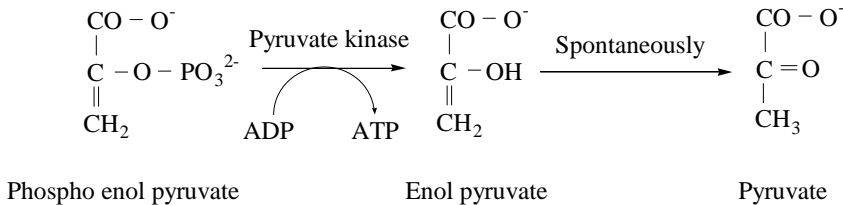

Actually, this reaction takes place in two steps. First the enolate form of pyruvate is formed, then the transfer of the phosphate group to ADP occur as second step. The keto pyruvic acid may reduced to lactic acid in the lack of oxygen. **Mitochondria is not involved** . Since one molecule of glucose yield 2 molecule of Glyceraldehyde 3 phosphate, 2 high energy ATP are produced for one molecule of glucose.

Phosphocreatine

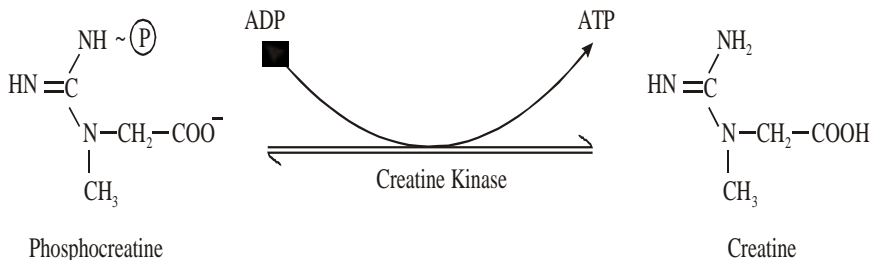

Phosphocreatine is a phosphogen and it interacts with ADP to form ATP. When ATP is more creatine reacts with ATP and forms phosphocreatine. The enzyme involved is creatine kinase. This energy transfer from creatine phosphate to ADP helps to produce ATP molecule to provide energy during muscle contraction.

8.4.2 ATP as high energy compound

ATP is the most widely distributed high-energy compound within the human body. Adenosine triphosphate (ATP) is a useful free-energy currency because the dephosphorylation reaction or hydrolysis, yield an **unusually large amount of energy**; *i.e.*, it releases a large amount of free energy. “High energy” bonds are often represented by the “~” symbol (squiggle), with ~P representing a phosphate group with a high free energy on hydrolysis. The terminal phosphate group is then transferred by hydrolysis to another compound, a process called *phosphorylation*, producing ADP, phosphorylated new compound and energy. **Thus, the dephosphorylation reaction of ATP to ADP and inorganic phosphate is often coupled with non spontaneous reactions.** Generally, ATP is connected to another reaction—a process called *coupling* which means the two reactions occur at the same time and at the same place, usually utilizing the same enzyme complex. Release of phosphate from ATP is exothermic (a reaction that gives off heat) and this reaction is connected to an endothermic reaction (requires energy input in order to occur). The free energy yielded can be coupled to endothermic reaction and useful for the works such as:

Chemical work: ATP energy is consumed to synthesize macromolecules that make up the cell.

Transport work: ATP energy is utilized to pump substances across the plasma membrane.

Mechanical work: ATP provides energy to contract the muscles of the body.

Some time the phosphate group can be transferred to an acceptor molecule and such group transfer potential are associated with some high energy compound. Thus, ATP act as a common intermediate that serves as a vehicle for transfer of chemical energy.

8.4.2.1 Structure of ATP

ATP is an abbreviation for *adenosine triphosphate*, a complex molecule that contains the nucleoside *adenosine*, ribose and a tail consisting of three phosphates.

Adenosine triphosphate

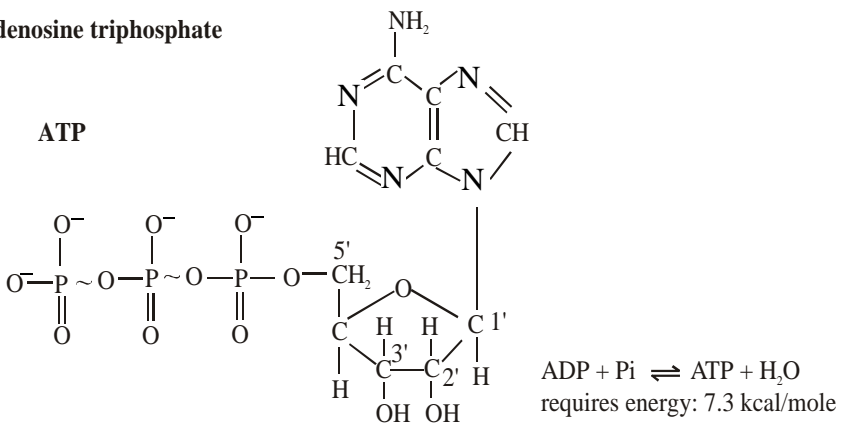

Fig.8.6 Adenosine triphosphate

The bond is known as a “high-energy” bond and is depicted in the figure 8.6 by a wavy line. The bond between the first and the second phosphate is also “high-energy” bond.

8.4.2.2 Free energy of hydrolysis of ATP



$$\Delta G^\circ = -7,300 \text{ calories/mol} = -7.3 \text{ kcal/mol} = -30.5 \text{ kJ/mol} \quad (\Delta G^\circ \text{ measured at } 37^\circ\text{C})$$

ATP is sometimes referred to as a “High Energy” compound. High energy in this case does **not** refer to total energy in compound, rather just **to energy of hydrolysis. Thus ATP has a large negative ΔG for hydrolysis.** For biochemistry *High Energy* is defined in terms of ATP: if a compound’s free energy for hydrolysis is equal to or greater than ATP’s then it is “High Energy,” if its free energy of hydrolysis is less than ATP’s then it is not a “high energy” compound. Note that ATP has two high energy anhydride bonds (AMP ~P~P). ΔG of ATP hydrolysis also depends on the local environments it varies with pH, divalent metal ion concentration, ionic strength and Consumption of ATP. An E_{ATP} of -7.3 kcal /mol requires ATP, ADP, and phosphate to be present at equal concentrations. In cells, however the concentration of ATP is often 5 to 10 times that of ADP.

As a result, the free energy of ATP hydrolysis is about -12 kcal / mol. One must be clear that the bond energy generally meant by physical chemist is the energy required to break a covalent bond between two atoms. Since relatively a large amount of energy is required to break a covalent bond, the phosphate bond energy is totally a different one. Phosphate bond energy specifically denotes the difference in the free energy of the reactants when phosphorylated compound undergoes hydrolysis.

8.4.2.3 Mono (ortho) phosphate cleavage and Pyrophosphate cleavage

ATP may undergo either an orthophosphate or pyrophosphate cleavage during its utilization in biosynthetic pathways. In an ATP molecule, when the terminal phosphate is cleaved it is called as mono phosphate or ortho phosphate cleavage.

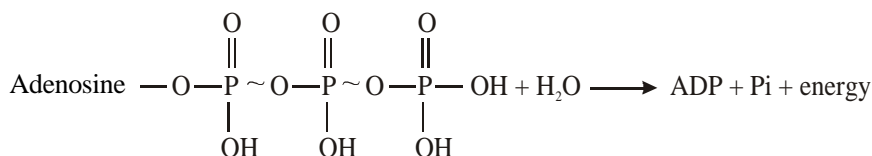

However, in many ATP utilizing reactions instead of one terminal phosphate two terminal phosphate groups are enzymatically hydrolyzed to give a pyro phosphate molecule and a large amount of energy which is greater than the mono phosphate or ortho phosphate cleavage.

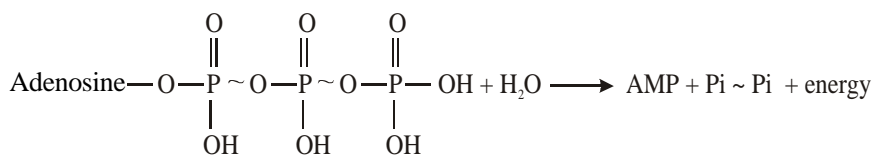

Pyrophosphate (PPi) is often the product of a reaction that needs a driving force. Its spontaneous hydrolysis, catalyzed by Pyrophosphatase enzyme, drives the reaction for which PPi is a substrate. The DG (free energy) for this pyrophosphate cleavage is 10.0 Kcal./mol and thus an extra thermodynamic push is given to certain enzymatic reaction which require more energy than that of a mono phosphate cleavage and assure the completeness of certain biosynthetic reactions.

Exercises

I. Choose the correct answers

- a) Which of the following is the high energy compound
- i) Glyceraldehyde
 - ii) AMP
 - iii) Pyrophosphate
 - iv) Lactate
- b) Which of the following is involved in Electron transport chain (ETC)
- i) Adenosin
 - ii) Non heme iron protein
 - iii) Creatine phosphokinase
 - iv) Adenylase cyclase
- c) Respiratory control of electron transport chain depends on
- i) ATPsynthetase
 - ii) ADP
 - iii) Ionophores
 - iv) Creatine
- d) Pyrophosphate cleavage leads to
- i) more energy cleavage leads to wastage
 - ii) completeness of certain bio synthetic reaction
 - iii) Transfer of phosphate group to another molecule
 - iv) activation of Electron transport chain
- e) Succinate dehydrogenase in mitochondria, is a marker of
- i) Inner membrane
 - ii) Outer membrane
 - iii) Inter membrane space
 - iv) Matrix

II. Fill in the blanks

- Process involving gain of electrons is _____ and loss of electron is _____
- Oxidation reduction reactions are other wise called as _____
- Direct transfer of energy from Phosphoenol pyruvate is an example for _____
- In the muscle cells energy is stored in the form of _____
- Un couplers in ETC are _____, _____ and _____.

III. Say True or False

- In muscle cell, when ATP is low the creatine phosphate is converted to ATP
- When FADH_2 is substrate in ETC, three molecule of ATP is formed
- F_1 factor is not essential for oxidative phosphorylation
- Hydrolysis of ATP to ADP gives more than 7.3 kilo calories of energy
- Removal of terminal phosphate group from ATP is called monophosphate cleavage

IV. Match the following

- | | |
|---|-------------------------------------|
| a. Cyanide | Reductant |
| b. NADH | Inhibits cytochrome oxidase |
| c. Uncouplers | Proton motive force |
| d. F_o and F_1 particle | Dissipate the H^+ gradient |
| e. Chemiosmotic energy is a | ATP synthetase |

V Short answers

- a. Energy conservation occurs in what transport system?
- b. What is known as power house of the cell?
- c. What are ionophores?
- d. What is the role of a phosphagens ?
- e. Role of Creatine phosphate in muscle?

VI Answer the following

- a. Who proposed the chemiosmotic theory ?
- b. What is the other name of ATP synthetase?
- c. Cyanide inhibits which components of ETC?
- d. In which part of Mitochondria, the ETC chain proteins are located?
- e. What is the other name of cytochrome C reductase ?

VI. Answer in detail

- a. Describe Chemiosmotic theory
- b. Site at which ATP are produced
- c. Pyrophosphate cleavage
- d. High energy compounds
- e. Mention the specific enzyme that marks the different components of mitochondria.

CHAPTER IX

Enzyme Kinetics

Introduction

For all enzymatic processes the rate of the reaction depends upon the concentration of the enzyme and its substrates, other conditions like temperature and pH being constant. Figure 9.1 shows the relationship between the substrate and product concentrations.

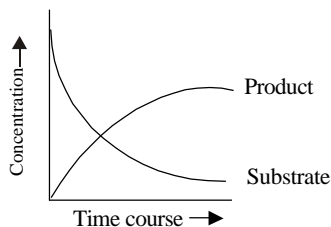

Fig .9.1 Relationship between substrate and product concentrations

Although the velocity increases linearly with enzyme concentration, at constant enzyme concentration it increases hyperbolically as the substrate concentration increases. This indicates that the enzyme has a definite number of sites to combine with substrate. When all sites are occupied, no further rate enhancement occurs and the enzyme is saturated with the substrate.

9.1 Derivation of M - M Equation

Leonor Michaelis and Mand L. Menton in 1913 proposed a successful explanation for the effect of substrate concentration on the enzyme activity.

According to them the enzyme E , and the substrate S combines rapidly to form a complex, the enzyme substrate complex ES. This complex then breaks down relatively and slowly to form the product P of the reaction .These sequence of reactions can be represented in the following equations

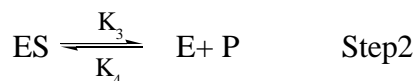
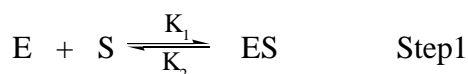

k_1 & k_2 are the rate constants of the forward and backward reactions (step 1)

k_3 & k_4 are the rate constants of the forward and backward reactions respectively (step 2)

This is true only for the enzyme reactions which fulfill the following conditions:

- i. only a single substrate and a single product are involved.
- ii. the reaction proceeds essentially to completion.
- iii. the concentration of the substrate is much greater than that of the enzyme in the system.
- iv. an intermediate enzyme substrate complex is formed.
- v. the rate of decomposition of the substrate is proportional to the concentration of the enzyme substrate complex.

It is assumed that the concentration of S is much greater than that of E and that only initial velocities are measured, where only a small fraction of S has been converted. Under these conditions, concentration of $P \rightarrow ES$ can be ignored.

Applying law of mass action to the first step of the reaction in which k_1 and k_2 are the rate constants for the forward and backward reaction respectively,

The rate of forward reaction = $k_1 [E] [S]$ (1)

The rate of backward reaction = $k_2 [ES]$ (2)

Applying law of mass action to the second step of the reaction in which k_3 and k_4 are the rate constants for the forward and backward reaction respectively,

The rate of forward reaction = $k_3 [ES]$ (3)

The rate of backward reaction can be neglected.

The total enzyme in the system can be represented as,

$$[Et] = [E] + [ES] \quad \dots\dots\dots (4)$$

Where [E] is the uncombined free enzyme concentration, [ES] the enzyme substrate concentration and [Et] the total enzyme concentration. The velocity of the overall reaction is

$$V = k_3 [ES] \quad \dots\dots\dots (5)$$

This is the actual rate equation for the overall reaction but it is not useful since neither k_3 nor $[ES]$ can be measured directly. It is assumed that the reaction proceeds at steady state where the rate of formation of $[ES]$ equals to the rate of degradation of $[ES]$.

The rate of formation of ES , V_f is proportional to E and S as in any second order reaction.

$$\begin{aligned}
 V_f &= k_1 [E] [S] \\
 &= k_1 ([Et] - [ES]) [S] \dots\dots\dots (6)
 \end{aligned}$$

The rate of disappearance of (ES) , V_d is

$$\begin{aligned}
 V_d &= k_2 [ES] + k_3 [ES] \\
 &= (k_2 + k_3) [ES] \dots\dots\dots (7)
 \end{aligned}$$

Since in the steady state $V_d = V_f$

$$k_1 ([Et] - [ES]) [S] = (k_2 + k_3) [ES] \dots\dots\dots (8)$$

Rearranging this equation gives

$$\frac{[S] ([Et] - [ES])}{[ES]} = \frac{k_2 + k_3}{k_1} = K_m \dots\dots\dots (9)$$

where K_m is the Michaelis – Menton constant, an useful parameter characteristic of each enzyme and a substrate.

Rearranging this equation by solving for [ES]

$$\frac{[S] [Et] - [S] [ES]}{[ES]} = K_m \quad \dots\dots\dots (10)$$

$$k_m [ES] = [S] [Et] - [S] [ES]$$

$$k_m [ES] + [S] [ES] = [S] [Et]$$

$$[ES] (K_m + [S]) = [S] [Et]$$

$$[ES] = \frac{[Et] [S]}{K_m + [S]} \quad \dots\dots\dots (11)$$

According to the previous equation (5), $V = k_3 [ES]$. Substituting the value of [ES] (11) in this equation we get ,

$$V = \frac{k_3 [Et] [S]}{K_m + [S]} \quad \dots\dots\dots (12)$$

The maximal velocity V_{max} is equal to

$$V_{max} = k_3 [Et] \quad \dots\dots\dots (13)$$

substituting the value of $k_3 [Et]$ in the equation (12), the final Michaelis – Menton rate equation becomes,

$$V = \frac{V_{max} [S]}{K_m + [S]} \quad \dots\dots\dots (14)$$

Now, when V is equal to half of the maximum velocity,

$$\text{i.e., } V = V_{\max} / 2$$

$$\text{Thus, } \frac{V_{\max}}{2} = \frac{V_{\max} [S]}{K_m + [S]} \quad \dots\dots\dots (15)$$

Rearranging,

$$K_m + [S] = 2 [S]$$

$$\text{Therefore, } K_m = [S] \quad \dots\dots\dots (16)$$

9.1.1 K_m Value Definition

K_m is defined as the concentration of the substrate at which the velocity of the reaction is half maximal. It is independent of enzyme concentration. The unit of K_m is moles per litre. Thus, Michaelis – Menton constant may be determined by a plot commonly known as M-M plot obtained by plotting substrate concentration $[S]$ versus rate of the reaction $[V]$ (Fig 9.2).

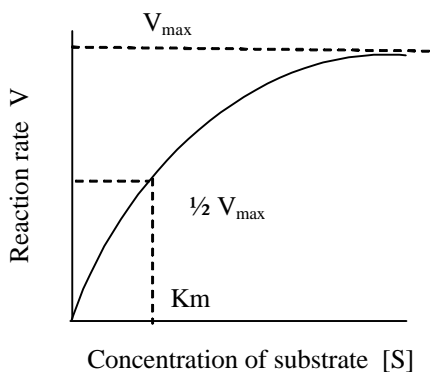

Fig.9.2 Michaelis Menton Plot

9.1.2 Lineweaver – Burk Equation

Transformation of the Michaelis – Menton equation

The value of K_m may be obtained more accurately from the Lineweaver - Burk equation which is obtained by taking the reciprocal of both sides of the Michaelis – Menton equation.

$$1/V = K_m + [S] / V_{\max} [S] \quad \dots \dots (1)$$

Rearranging this equation ,we have

$$1/V = K_m / V_{\max} [S] + [S] / V_{\max} [S] \quad \dots \dots (2)$$

which is further simplified to

$$1/V = K_m / V_{\max} \cdot 1/[S] + 1/ V_{\max} \quad \dots \dots (3)$$

A plot of $1/V$ versus $1/S$ (a double reciprocal plot) yields a straight line with the slope of K_m / V_{\max} and ordinate intercept of $1/ V_{\max}$. Since the slope and intercept are readily measured from the graph, the V_{\max} and K_m can be accurately determined (Fig 9.3).

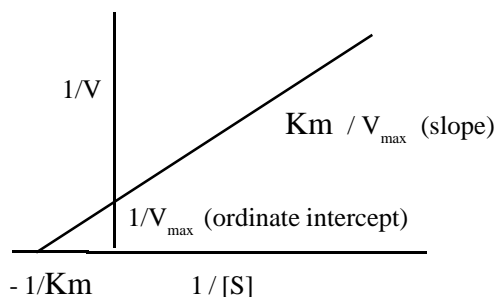

Fig. 9.3 Lineweaver - Burk Plot

9.2 Enzyme Action

The molecular events that accompany the conversion of substrate into products constitute the mechanism of enzyme action. Enzyme action on its substrate results either in the formation or degradation of chemical bonds in the substrate molecules.

9.2.1 ES Complex Formation

According to Michaelis – Menton theory, the enzyme E combines with the substrate S to form an intermediate enzyme substrate complex ES. This complex then breaks down into product P and enzyme E is regenerated. The enzyme can again combine with the fresh molecule of the substrate in similar manner. The formation of enzyme substrate complex as an intermediate during the reaction has been proved by spectroscopic studies. So, a simple enzymatic reaction might be written as

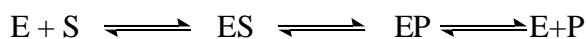

Where E, S and P represent enzyme, substrate and product respectively. ES and EP are complexes of the enzyme with substrate and product respectively. At the end of the reaction along with the required products the enzyme is regenerated in its original form and can involve in another round of catalysis. ES complex is a highly energised, transiently existing complex which can be easily degraded to form the product.

In the formation of enzyme substrate complexes, the substrate molecules attach at certain specific sites on the enzyme molecules. These specific points on enzyme molecules where the substrate molecules attach are known as active site or catalytic site.

Active sites on the enzymes are usually provided by certain functional group of amino acids present in the enzyme protein. For example, free hydroxyl group of serine, phenolic group of tyrosine, sulfhydryl group of cysteine and imidazolyl group of histidine are some of the important catalytic groups present in enzyme active sites.

9.2.2 Theories of Active Site

In 1894, Fischer proposed that the substrate fits into the active site of the enzyme as a key fits into the lock (**Fig 9.4**). Because of this model, the theory is known as lock and key theory of enzyme action.

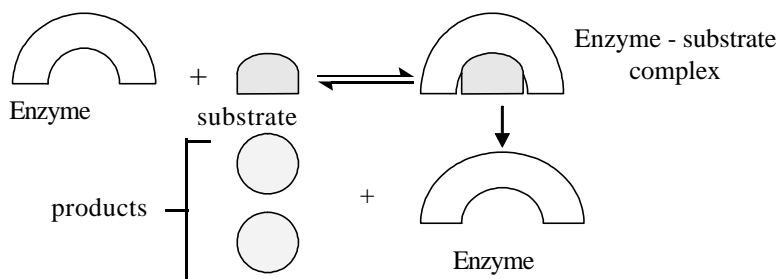

Fig 9.4 Lock and Key Theory of Fischer

According to lock and key theory, there are exact functional groups and structural features in the enzyme into which substrate molecule must fit. The region of the enzyme that complexes with the substrate is called active site or catalytic site. The theory cannot be applied for all the enzymatic reactions because in some reactions the substrate molecules and the active site are not structurally similar to fit in with each other. Moreover, in certain cases the catalytic activity is observed even though a fit is impossible.

Later, lock and key theory was modified by Koshland in 1963 in the form of 'induced fit mechanism'. The essential feature of this theory is the flexibility of the enzyme active site. In Fisher model, the active site is presumed to be a rigid preshaped structure to fit the substrate, while in the induced fit model the substrate induces the conformational change in the enzyme (Fig 9.5), so that the substrate and active site come close to each other in such a way that the substrate fits the active site in a more convenient manner.

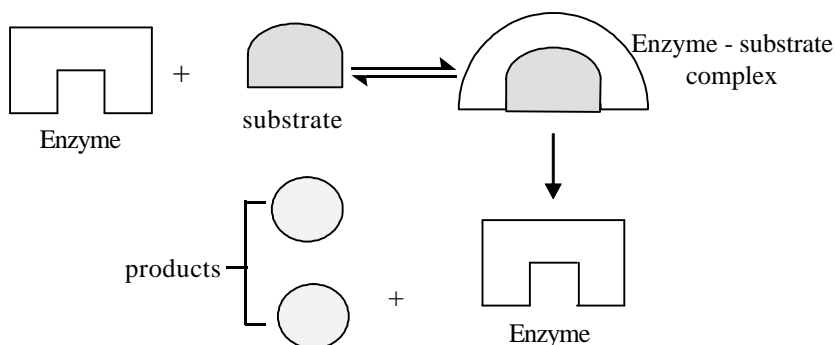

Fig. 9.5 Induced Fit Model of Koshland

The active site on the enzyme molecule exerts a binding force on the substrate molecule by hydrophilic and hydrophobic catalytic groups. Enzyme substrate complexes are formed by multiple bonding i.e., covalent, electrostatic and hydrogen bonding with the substrate. The functional group at the active site are arranged in a definite spatial manner so that the ES complex formation is favourable.

Many enzymes require non proteinous group called as coenzymes for their maximal activity. The enzymes requiring coenzymes for their activity

also possess sites for the attachment of co-enzymes. The complexes formed in such cases are known as enzyme-substrate-coenzyme complexes.

Certain enzymes require a metal ion, in addition to coenzyme for their full activity. These metallic ions are called positive modifiers of enzyme activity. Examples of such enzymes include alcohol dehydrogenase, peroxidase, catalase and xanthine oxidase etc., which contain sites for binding metal ions. The removal of metal from these enzymes often results in partial or total loss of enzymatic activity. These enzymes are otherwise called as metallo enzymes. The common metallic ions required for enzymatic activity are K^+ , Cu^+ , Mg^{++} , Ca^{++} etc.

9.3 Enzyme Inhibitor - Concepts

The rates of enzyme catalysed reactions are decreased by specific inhibitors. Inhibitors are compounds that combine with enzymes and prevent enzyme and substrate from forming ES complex. The toxicity of many compounds such as hydrogen cyanide and hydrogen sulphide results from their action as enzyme inhibitors. Many drugs also act to inhibit specific enzymes. Thus, knowledge of enzyme inhibitors is vital to understand drug action and toxic agents.

Compounds which convert the enzymes into inactive substances and then adversely affect the rate of enzyme catalysed reactions are called as enzyme inhibitors. Such a process is known as enzyme inhibition. Two broad classes of enzyme inhibitors are generally recognized. They are reversible and irreversible inhibitors. This depends on whether the inhibition can be reversed or not.

9.3.1 Reversible Enzyme Inhibition

A reversible enzyme inhibitor dissociates very rapidly from its target enzyme because it becomes very loosely bound with the enzyme. Three general types of reversible inhibition is observed: competitive, non-competitive and un-competitive, depending on the following factors.

1. Whether the inhibition is over come or not by increasing the concentration of the substrate.
2. Whether the inhibitor binds with the active site or site other than the active site (allosteric site).
3. Whether the inhibitor binds with the free enzyme only or with the enzyme substrate complex only or with either of the two.

9.3.1.1 Competitive Inhibition

Competitive inhibitors can combine reversibly with the active site of enzyme and compete with the substrate for binding with the active site. If the site is occupied by the inhibitor it is unavailable for the binding of the substrate (**Fig 9.6**). The competitive inhibitor always resembles the structure of the substrate. In some cases competitive inhibitors are exact structural analogues of the substrates. The combination of a competitive inhibitor (I) with enzyme (E) can be written in the same manner as combination with substrate, although the inhibitor cannot be chemically transformed to products.

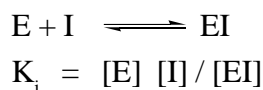

K_i is equal to the dissociation constant for the enzyme – inhibitor complex EI.

The degree of inhibition depends upon the relative concentration of the substrate and the inhibitor. It also depends on the relative affinity of inhibitor towards enzyme active site. Thus, by increasing the substrate concentration we can decrease the degree of inhibition keeping inhibitor concentration at constant level.

The classic example is the inhibition of succinate dehydrogenase by malonate and other dicarboxylic acids. Succinate dehydrogenase is a member of the group of enzymes catalyzing the Krebs tricarboxylic acid cycle.

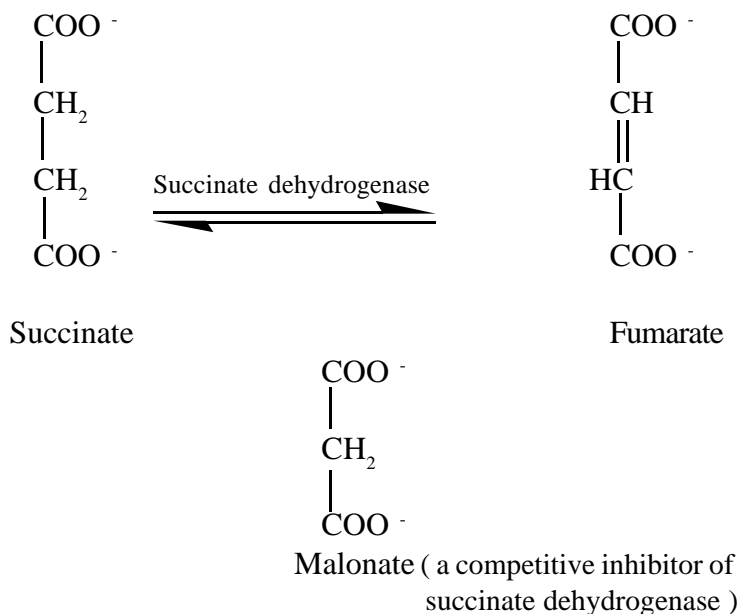

It catalyzes the removal of two hydrogen atoms from the two methylene carbon atoms of succinate. Succinate dehydrogenase is inhibited by malonate, which resembles succinate in having two ionized carboxyl groups.

Many micro organisms like bacteria synthesize the vitamin folic acid from para-aminobenzoic acid. Sulphanilamide and other sulfa drugs are structural analogs of para-aminobenzoic acid. So, sulfa drugs act as competitive inhibitor and occupy the active site of some bacterial enzyme catalyzing this reaction. When this reaction is affected, it blocks the folic acid biosynthesis which is essential for the growth of micro organisms, ultimately results in the death of the micro organisms. Thus, many sulfa drugs act as antibiotics

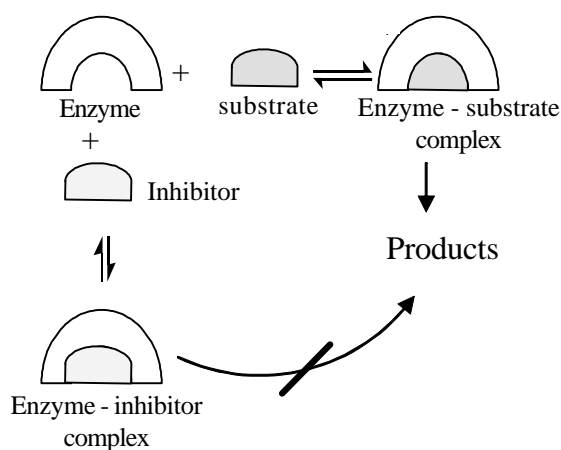

Fig. 9.6 Competitive inhibition

9.3.1.2 Un-competitive Inhibition

This type of inhibition occurs when an inhibitor combines reversibly only with ES to form ESI which cannot yield the products.



$$K_i = [ESI] / [ES] [I]$$

K_i = dissociation constant of ESI complex.

An un-competitive inhibitor also binds at an allosteric site and the binding takes place only in enzyme substrate complexes and not with the free enzyme molecule (Fig 9.7).

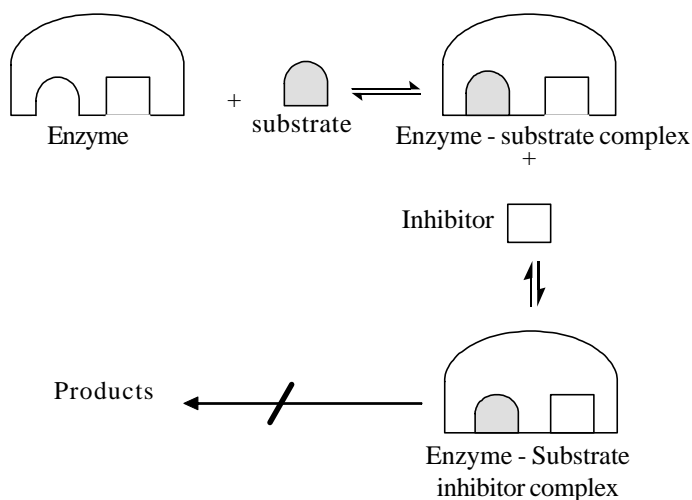

Fig. 9.7 Uncompetitive inhibition

9.3.1.3 Non-competitive Inhibition

In this type of inhibition no competition occurs between the substrate and the inhibitor and the inhibitor has no structural resemblance with the substrate and it binds with the enzyme at a place other than the active site. Since I and S may combine at different sites, formation of both EI and ESI complexes takes place (Fig 9.8). The enzyme is inactivated when inhibitor is bound, whether the substrate is present or not. Non competitive inhibition in contrast to competitive inhibition cannot be overcome by increasing substrate concentration. For example various heavy metal ions such as Ag^{2+} , Hg^{2+} , Pb^{2+} inhibit the activity of a variety of enzymes. Urease can be inactivated by any one of these metal ions.

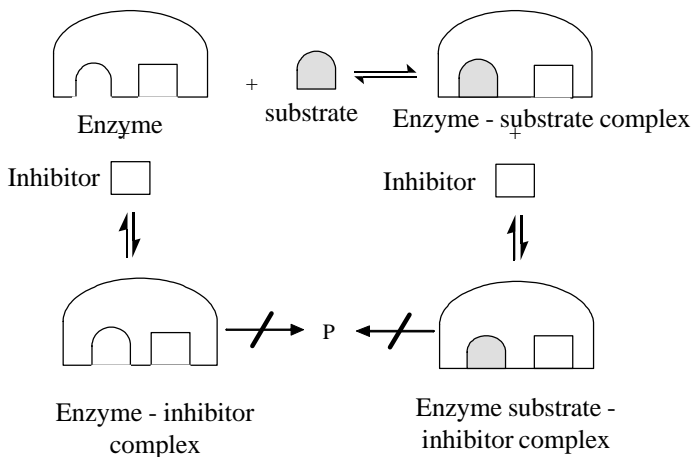
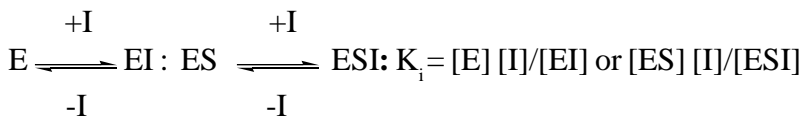

Fig. 9.8 Noncompetitive inhibition

9.3.2 Irreversible Enzyme Inhibition

Irreversible inhibitors are those that combine with or destroy a functional group on the enzyme that is essential for its activity. The irreversible inhibitor dissociates very slowly from its target enzyme because it becomes very tightly bound to its active site, thus inactivating the enzyme molecule. The bonding between the inhibitor and the enzyme may be covalent or noncovalent.

Examples of Irreversible Inhibition

1. Alkylating agents such as iodoacetamide, irreversibly inhibit the catalytic activity of some enzymes by modifying cysteine and other side chains.
2. Organo phosphorous compounds such as diisopropyl phosphorofluoridate are potential irreversible inhibitors of enzymes that have active seryl residues at their catalytic sites.

Exercises

I. Choose the correct answer from the four given alternatives

- 1 ES complex formation is
 - a) a reversible reaction
 - b) an irreversible reaction
 - c) an energy consuming reaction
 - d) a complete reaction

2. According to Michaelis Menton theory
 - a) only a single substrate is involved
 - b) the concentration of substrate is much greater than that of enzyme
 - c) an intermediate enzyme substrate complex is formed
 - d) all the above

3. The reciprocal form of M-M equation was considered by
 - a) Lineweaver - Burk
 - b) Fischer
 - c) Koshland
 - d) Dixon

4. Lock and Key theory was proposed by
 - a) Dixon
 - b) Fischer
 - c) Koshland
 - d) Michaelis Menton

5. An exact structural similarity with the substrate is needed for a
 - a) competitive inhibitor
 - b) uncompetitive inhibitor
 - c) non competitive inhibitor
 - d) irreversible inhibitor

II. Fill in the blanks

1. While deriving Michaelis Menton equation it should be considered that the concentration of _____ is much greater than that of the _____ in the system.
2. The total enzyme in Michaelis Menton equation is represented as _____ .
3. Koshland proposed _____ theory.
4. Metal requiring enzymes are otherwise known as _____ .
5. In _____ type of inhibition, the inhibitor has got attraction towards ES complex.

III. Say True or False.

1. Enzyme substrate complex is a permanent stable complex.
2. Malonate is the competitive inhibitor of succinate dehydrogenase.
3. An enzyme substrate complex is formed in all the enzymatic reactions.
4. The degree of competitive inhibition cannot be decreased by increasing the concentration of the substrate.
5. An uncompetitive inhibitor has affinity towards ES complex.

IV. Match the following

- | | | |
|-----------------------------|---|-------------------------------|
| 1. Enzymes | - | 1/V vs 1/S |
| 2. ES complex | - | ESI complex |
| 3. k_m | - | Unstable and highly energetic |
| 4. Lineweaver - Burk plot | - | Biocatalysts |
| 5. Uncompetitive inhibition | - | A constant factor |

V. Give short answer for the following

1. Define K_m
2. What is the nature of active site according to lock and key theory ?
3. What is competitive inhibition ?
4. What is induced fit theory ?
5. What is irreversible enzyme inhibition ?

VI. Answer the following

1. Derive MM equation.
2. How is LineWeaver Burk plot arrived ?
3. Explain the concept of competitive inhibition
4. What is the action of malonate on succinate dehydrogenase ?
5. Compare competitive and non-competitive inhibition.

CHAPTER X

Immunology

Introduction

The Latin term “immunis” meaning “exempt” gave rise to the English word “immunity”, which refers to the mechanisms used by the body to protect against environmental agents that are foreign to the body. These agents may be microorganisms or their products, foods, chemicals, drugs, pollen or animal hair.

10.1 Infections

The invasion and multiplication of a parasite in or on the surface of host tissue constitute infection. Infection and immunity involve interaction between the body (host) and the infecting microorganism. Based on their relationship to their host, microorganisms classified as saprophytes (free living microbes that subsist on dead or decaying organic matter, mostly found in soil). Parasites (establish themselves and multiply in hosts (it may be pathogens - disease producing) or commensals (without causing any damage to the host-normal flora). Infections may be classified in various ways.

- Primary infection** : First time infection with a parasite in a host.
- Secondary infection** : When new parasite sets up an infection in a host whose resistance is lowered by a preexisting infectious disease.
- Focal infection** : Infection or sepsis at localized sites (tonsils).
- Cross infection** : When a patient already suffering from a disease a new infection is set up from another host or another external source.
- Reinfections** : Subsequent infections by the same parasite in the host.
- Nosocomial infections** : Cross infection occurring in hospitals .
- Latent infection** : Some parasites, following infection, may remain in the tissues in a latent or hidden form, multiply and producing clinical disease when the host resistance is lowered.
- Sources of infection** : Many pathogens are able to infect, which may be from
1. Human beings to human beings, or from animals to human beings (Zoonotic disease eg – Plague).
 2. From insects to human beings (arthropod borne disease eg Malaria).
 3. From soil, water and contaminated food. This may enter the host by either, direct **contact** (contagious disease) **or** indirect (like clothing). It may also occur by
 - i) **Inhalation** of pathogen (Influenza)
 - ii) **Ingestion** of food or drinks contaminated by pathogens
 - iii) **Inoculation** directly into the tissues of the host (Tetanus spores).
 - iv) Congenitally some pathogens (eg) rubella virus) are able to cross the placental barrier and infect the fetus in utero (Vertical transmission).

Infectious disease may be localized (superficial or deep-seated) or generalized (spreading through tissue spaces and circulation). However, it can be **Endemic** (when a small number of cases occur constantly among the population of a community eg: Typhoid), **Epidemic** (The disease flares up and large number of cases develop within a community within a short time. eg: Influenza) or **Pandemic** (when an epidemic becomes very widespread areas in the world involving large number of people within a short period).

10.1.1 Bacteria

Bacteria are unicellular prokaryotic organisms. Based on the structure and shape three major groups of bacteria namely, Bacillus (cylindrical forms), Coccus (spherical forms) and Spiral. Humans and animals have abundant normal flora (microbes) that usually do not produce disease under normal healthy conditions. The pathogenesis of bacterial infection includes initiation of the infectious process and mechanisms that lead to the development of signs and symptoms of disease. Many bacterial infections are considered pathogenic, though they are unapparent or asymptomatic.

Table 10.1 Infection / Disease and Causative Agents

Infection /Disease	Causative agent
Tuberculosis	<i>Mycobacterium tuberculosis</i>
Meningitis	<i>Haemophilus influenzae</i>
Cholera	<i>Vibrio cholerae</i>
Bacillary dysentery	<i>Shigella species</i>
Botulinum(food poison)	<i>Clostridium botulinum</i>
Tetanus	<i>Clostridium tetani</i>
Leprosy	<i>Mycobacterium leprae</i>
Typhoid (Enteric fever)	<i>Salmonella typhi</i>
Syphilis	<i>Treponema pallidum</i>

10.1.2 Viral infections

Virus are acellular obligate intracellular parasites. It contain only one type of nucleic acid, it may be either single or double stranded DNA or RNA. The extracellular infectious virus particle is called the virion. The virion consists of nucleic acid surrounded by a protein coat called **capsid** which protects the nucleic acid from deleterious environment and to introduce viral genome into the host cells by adsorbing readily to the cell surface.

Pathogenesis of viral infection

Viral diseases range from minor ailments such as the common cold to terrifying diseases such as Rabies and Acquired Immune Deficiency Syndrome (AIDS). They may be sporadic like Mumps, endemic like Infectious hepatitis, epidemic like Dengue fever or pandemic like Influenza. Depending on the clinical outcome, viral infections can be classified as unapparent (sub clinical) or apparent (Clinical or overt) infections.

Table 10.2 Disease and Causative Agents

Disease	Causative agent
Chicken pox	Varicella
Burkitt's lymphoma	Epstein Barr virus
Pneumonia	Adenovirus
Poliomyelitis	Poliovirus
Mumps	Mumps virus
Rabies	Rabies virus
Jaundice	Hepatitis A
AIDS	Human Immuno Deficiency Virus

10.1.3 Fungi

Fungi are eukaryotic protista, recognized as causative agents of human disease earlier than bacteria. Fungi possess rigid cell wall containing chitin, mannose and other polysaccharides. They divide asexually, sexually or by both processes. They may be unicellular or multicellular. Depending on the cell morphology fungi can be divided into four classes-

- i) **Yeasts** : Unicellular fungi which occur as spherical and reproduce by simple budding
- ii) **Yeast like fungi** : Grow partly as yeast and partly as elongated cells resembling hyphae form a pseudo mycelium
- iii) **Moulds** : True mycelia and they are reproduced by the formation of different types of spores.
- iv) **Dimorphic fungi** : Occur as filaments (soil) or as yeasts (host tissues) depending on the conditions of growth.

Human fungal infections are usually of two types **superficial** and **deep seated**. Fungi causing superficial mycoses are specialized saprophytes, with the capacity to digest keratin. Superficial mycoses are of two types - **surface infections** (only on dead layers of skin) and **cutaneous infections** (cornified layer).

Human fungal infections are detailed in Table 10.3.

Table 10.3 Human fungal infections

Dermatophytoses	
Infection	Causative agent
Ringworm	Tinea corporis - ringworm of the smooth or non hairy skin of the body
Itch	Tinea barbae - involvement of the bearded areas of the face and neck
Ringworm	Tinea capitis - ring worm of the scalp
Subcutaneous mycoses	
Infection	Causative agent
Mycetomas	Actinomycetes and Filaments fungi
Rhinosporidiosis	Rhinosporidium seeberi
Systemic mycoses	
Infection	Causative agent
Blastomycosis	Blastomyces dermatitidis
Histoplasmosis	Histoplasma capsulatum

10.2 Immunity

Disease spreads from one person to another is called as infectious disease. Infectious diseases are caused by foreign substances like fungi, bacteria, virus or parasite, when they enter in to the human body. Though the disease by such pathogen affects the body for a shorter duration, the person may survive after losing functions of some of

the organ (eg. Poliomyelitis). Some times, when the infection or disease is severe the person has to die. Yet many of the human beings are able to lead a normal life because of the immune system. The immune system provides such freedom enjoyed by an individual, in order to keep them free from diseases.

The immune system has the following the functions,

1. Recognition and defense against foreign substances (antigen) irrespective of the route of entry.
2. Depending upon the nature of the pathogen, appropriate immune reaction is mounted.
3. The antigen induced Antibody combine specifically to that antigen (Specificity)
4. Immune system keep memory about the pathogens and when the same pathogen reenters a better immune response is produced. This forms the basis of vaccination.
5. Recognition and destruction of the mutant cells that can become cancerous and this is know as Immunosurveillance.
6. Normally, Immune system does not produce antibodies against its own body tissues (self antigens), called as **Immune tolerance or Self recognition.**

Depending on the nature of response towards the pathogen, Immune system is broadly classified into Natural and Acquired immunity. Immune system is classified as follows.

Classification of Immunity

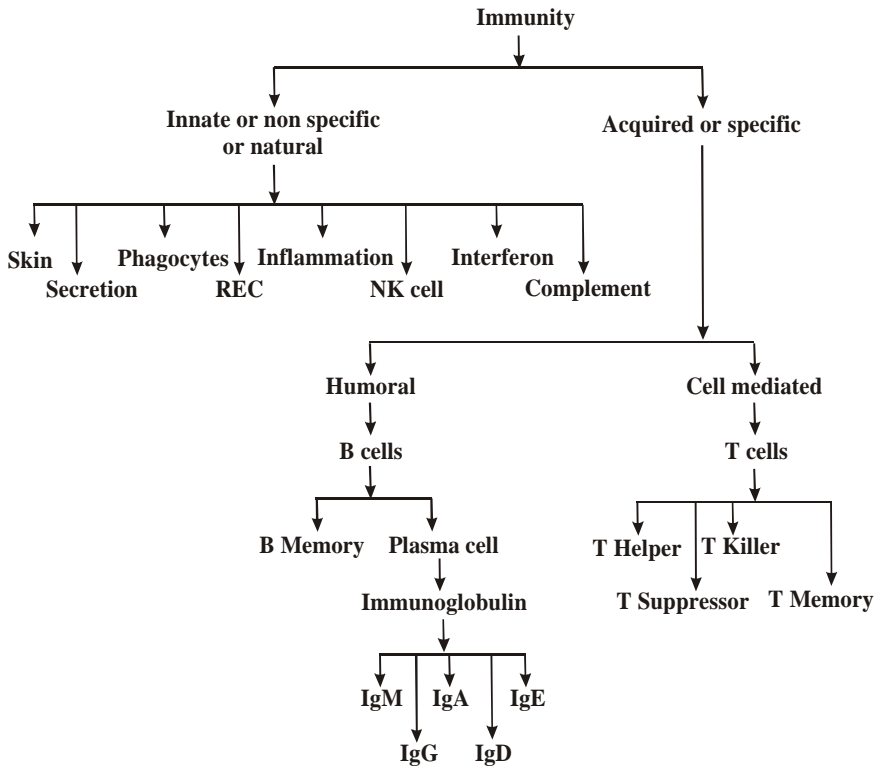

10.2.1 Natural Immunity

The non specific immunity present from birth is known as *innate immunity* or *natural immunity*. It protects the body against any foreign invaders and does not show any specificity. It is also functionally matured in a new born. It does not become more efficient after subsequent exposures to same organism.

10.2.1 Components (Cell types) involved in immunity

The cells of the immune system include leukocytes, which are also known as white blood cells (WBC). They developed from the bone marrow stem cells and give rise to two families of white blood cells namely the

Myeloid cells (named after bone marrow) and the *Lymphoid* cells, which take their name from the lymphatic system. Myeloid cells include *Basophils*, *Eosinophils* and *Neutrophils*.

The **monocytes** give rise to **macrophages** when enter into the tissue space from blood circulation. Similarly, **Basophil** are transformed to **mast cells**. The **lymphoid cells** include **T and B lymphocytes** which get their **maturation in different lymphoid organs**. B-cell maturation begins in the liver (fetal) and continues within the bone marrow as maturation progresses (adult) and **T cells** complete their **maturation in the thymus**.

Mechanisms involved in Natural immunity

Skin barrier

The skin covers and protects the body as a barrier to prevent invading pathogens. Intact skin prevents the penetration of most pathogens, by secreting lactic acid and fatty acids which lower the skin pH.

Mechanical barriers

Mucous membranes form the external layer where body is not covered with skin and it plays an important role in the prevention of pathogen entrance by trapping them. Movement of the mucociliary process in the upper respiratory tract, the cilia in the eyelids act as escalators to remove the pathogens.

Secretions

Sweat has antibacterial substances and tears contain lysozyme. Mucous secretion in nose prevents the dust and microorganism entry into

the respiratory tract. Saliva contains lysozyme, thiocyanate and lactoferrin. The HCl acid secreted in the stomach kills the microbes.

Phagocytosis

The ingestion (endocytosis) and killing of microorganisms by specialized cells called as phagocytes. Phagocytes are polymorphonuclear leukocytes (eg. Neutrophils) and mononuclear cells (Monocytes and Macrophages). **Opsonization** - The process by which microbes are coated by a molecule called opsonin which aids attachment of microbes to the phagocytic cells which facilitates phagocytosis. Neutrophils constitutively express ligands and receptors (L-selectin) which interact with reciprocal receptors and ligands on endothelial cells (P- and E-selectin). The endothelial cells are located in the innermost layer of the blood vessels. These interactions help the neutrophils to **marginate** and **roll** along the endothelium. Neutrophil responds and move towards a group of molecules called chemo-attractants (chemical mediators) and this process is called **chemotaxis (chemical attraction)**. The phagocytes make its way through intact capillary walls and into the surrounding tissue by a process called **diapedesis** (emigration of phagocytes into tissues). Chemo-attractants include complement protein C5a, bacterial products, cytokines, lipid mediators from injured tissue. The various stages of Phagocytosis given below.

Stages of Phagocytosis (Fig. 10.1)

Opsonization (process by which microbes are coated by a molecule called opsonin). Attachment to the pathogen (so that pathogen movement can be restricted).

1. Formation of Pseudopodia (hand like projections).

2. Encircling of pathogen by pseudopodia leads to the formation of Phagosome.
3. Fusion of Phagosome with lysozyme vesicle leads to the formation of phagolysosome.
4. Killing of Pathogen.

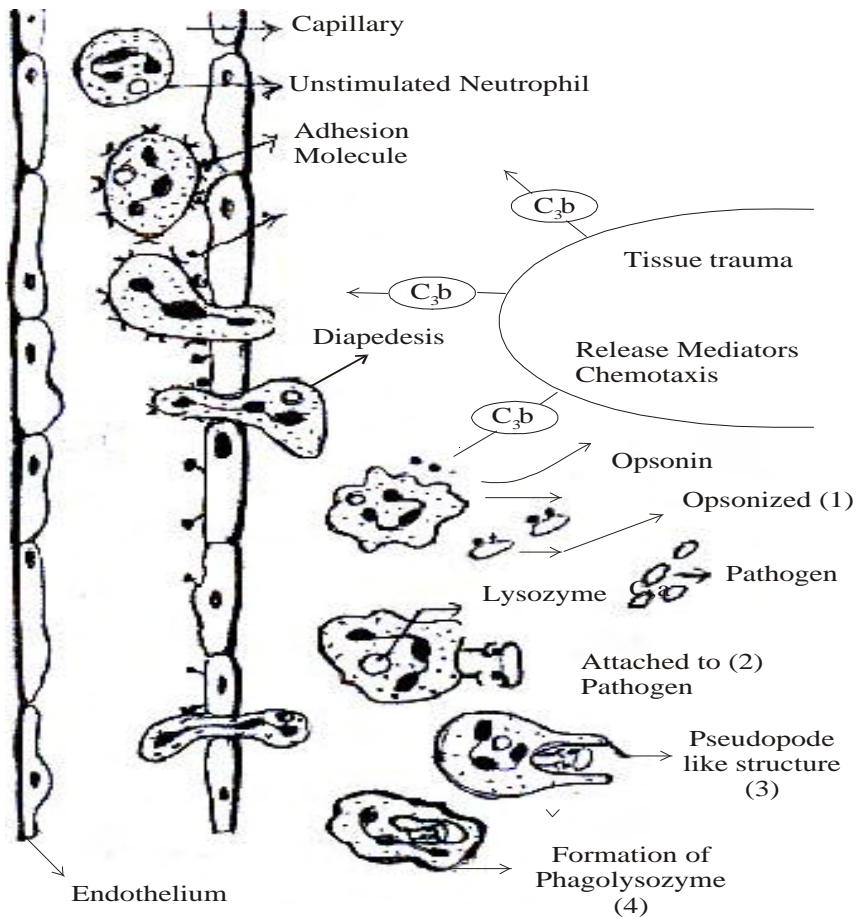

Fig 10.1 Process of Phagocytosis

Killing by phagocytes

Neutrophil are able to kill the pathogen as they possess certain chemicals in the form of granules and also the lysozyme enzyme. Neutrophil invasion to an inflamed area is considered as the second line of defence. Neutrophil has three types of granules namely **Primary granules** (contain ~~serine proteases, lysozyme and phospholipase A₂~~) **Secondary granules** (include perforin, elastase and collagenase) and **Tertiary granules** (contain gelatinase). Apart from these granules the phagocytes also possess a variety of **oxygen dependent** killing mechanisms. Phagocytes produce a respiratory burst, which produces superoxides and hydrogen peroxide. Neutrophils contain an enzyme called as **myeloperoxidase**, which can convert superoxide into hypochlorite ion which has a strong bactericidal activity.

Reticulo endothelial system (RES)

A diffuse system of cells that includes monocytes and macrophages, which are phagocytic in nature. The role of macrophage is considered as first order defence mechanism, as it engulf and kill more pathogens efficiently. Macrophages also take part in antigen presentation. Apart from this, RES also involved in removing aged RBCs, denatured protein, steroids, dyes and drugs.

The macrophages derive the name according to their location.

Liver	-	Kupffer cells
Brain	-	Microglial cells
Kidney	-	Mesangial cells
Spleen	-	Splenic macrophages
Peritoneum	-	Peritoneal macrophages.
Alveoli	-	Alveolar macrophages.

Inflammation

A localized protective reaction produced in tissue response to any irritation, injury or infection is called as inflammation. This is characterized by pain, redness, swelling, and sometimes loss of function. Usually, the name of the tissue, organ and the region which develops inflammation is suffixed with 'itis' for example conjunctivitis, gastritis and pharyngitis respectively. The inflammatory response helps to mobilize the nonspecific defense forces to the tissue space where pathogen is present. The damaged cells release chemical mediators such as histamine from the mast cells, which dilate the near by blood vessels. The complement system gets activated and attracts phagocytes. The plasma leaking from the dilated blood vessel contains clotting system of proteins. They get activated due to the tissue damage and this process leads to “walling off” the area and this helps to prevent spreading of the infectious material.

Natural Killer Cells

Among the immune cells, natural killer cells (NK cells) are the most aggressive. They are first line of defense against infected and cancerous cells. They are lymphocytes (Large granular lymphocytes, LGL) with no immunological memory and are part of the innate immune system. It attaches to the target and releases a lethal burst of chemicals called as perforins that penetrate the cell wall. Fluids begin to leak in and out and eventually the cell explodes.

Interferon

Interferons are proteins produced by body cells when they are invaded by viruses, is released into the bloodstream or intercellular fluid, in order to induce healthy cells to manufacture an enzyme that block viral replication.

Complement System

It is a group of proenzymes. They circulate in serum in inactive form. The complement system is the part of innate immune system plays an important defense against microorganisms, especially gram-negative bacteria. The complement system consists of a set of over twenty serum proteins which are getting activated as follows.

Antigen-antibody complex (classical pathway)

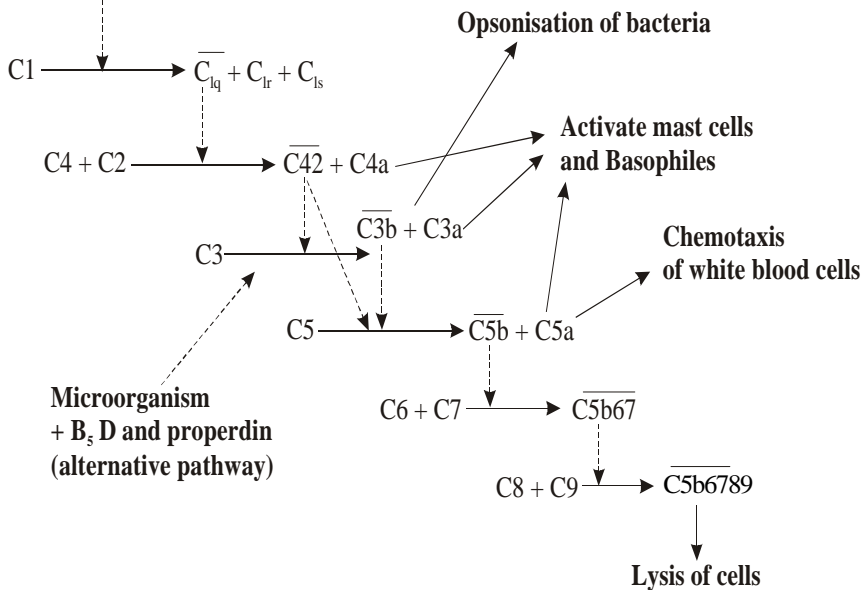

Fig 10.2 Classical and Alternative of Complement System

The complement cascade consists of two separate pathways that converge in a final common pathway (Fig.2). The pathways include the **classic pathway** (C1qrs, C2, C4), the **alternative pathway** (C3, factor B, properdin) and these two pathways converge at the component C3. The terminal complement pathway consists of all proteins activated after

C3. The most notable are C5-C9 group of proteins collectively known as the *membrane attack complex* (MAC). The MAC exerts powerful killing activity by creating perforations in cellular membranes. Activated C3b opsonizes bacteria and C5a function as chemotactic agent.

Antigen presenting cells (APC)

B cell, dendritic cells (lymphnodes), Langerhans cells (from skin) and macrophages are called as antigen presenting cells. All these cells, process the antigen and express the antigen over the surface of its cell membrane along with a molecule called as Major Histo Compatibility Complex (MHC) class II molecule.

Major Histocompatibility complex

A set of cell surface glycoproteins are called as the Major Histocompatibility Complex or MHC molecules. Generally, they take part in differentiating self and non self antigens and the presentation of processed foreign antigen to activate the T cells. There are two classes of MHC proteins, MHC class I and MHC class II. MHC class I molecule is expressed on the cell surface of all nucleated cells of the body. MHC class I molecules with processed antigen are expressed on the surface of the infected cells, which present the processed antigen to cytotoxic T cells (CD8). MHC class II molecule are expressed on APC cell surface which present the processed antigen to Helper T cells (CD4 cells).

10.2.2 Acquired immunity

Producing specific cells and molecules which are directed against the foreign invaders. It has the special ability to keep memory of first time

exposure of an antigen (primary immune response) and mounts better response when there is second time exposure of same antigen (secondary immune response). This ability of immune response forms the basis for the immunization or vaccination.

Acquired immunity is classified into humoral immunity and cell mediated immunity. Both humoral and cellular immune responses are evoked during antigen exposure.

The acquired immunity can be either active or passive.

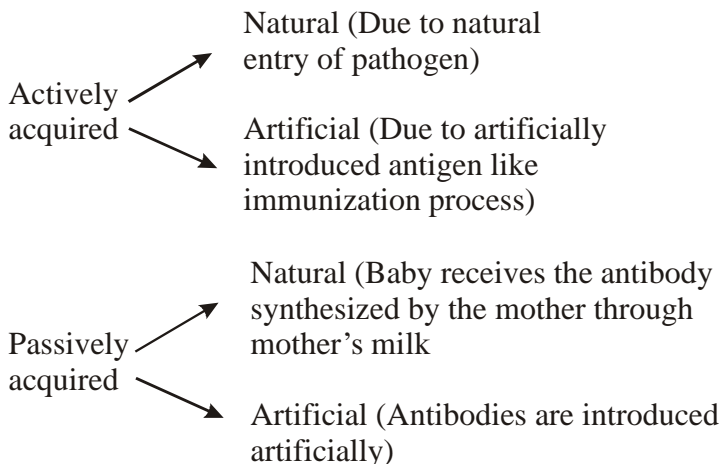

10.2.3 Humoral immunity

The humoral immune response begins with the recognition of antigen. Though the classification separates the cell mediated and humoral immunity with different cell types they do interact to bring an effective immune response. Specific T-cells are stimulated to produce lymphokines that are responsible for the antigen-induced B-cells proliferation and differentiation.

This is for the T depended antigens. However some of the macro antigenic molecules can directly stimulate the B cells directly. Through a

process of clonal selection specific B-cells are stimulated, the activated B-cell first develops into a B-lymphoblast, becoming much larger and shedding all surface immunoglobulin. This terminal differentiation stage is responsible for production of primarily IgM antibody during the primary immune response. Few newly differentiated B-cells remain as long-lived “memory cells” without secreting antibodies. Upon subsequent encounter with antigen, these cells respond very quickly to produce large amounts of IgG, IgA or IgE antibody, generating the better secondary immune response.

Pathogen or foreign protein + Macrophage / dendritic cells → processed antigen

Processed antigen + MHC II molecule → Recognized by T- helper cells

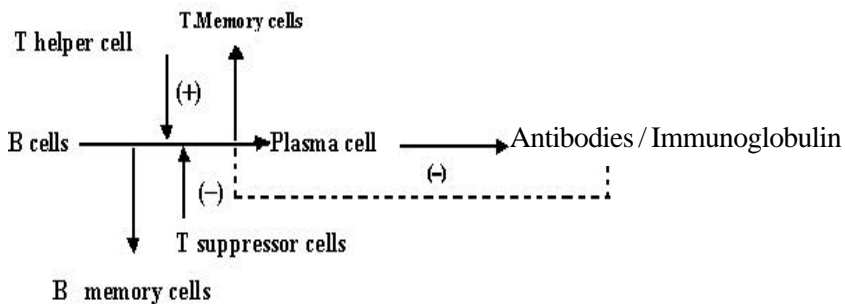

The initial differentiation step that ultimately leads to the mature B-cell involves DNA rearrangements in heavy chain variable (V) region as well as similar rearrangements within the light chain genes to synthesis immunoglobulin. These stages are, of course, initiated upon encounter with antigen and activation by T-helper cell to secrete lymphokines. The activated B-cell first develops into a B-lymphoblast, becoming much larger.

IgM antibody is formed during the ‘**primary immune response.**’ Instead, these cells undergo secondary DNA rearrangements to modify the constant region and forms **IgG, IgA or IgE** antibodies during **secondary immune response.** The suppressor T-cells suppresses the immune response once an adequate amount of antibody formed. Another way of suppression occurs by the produced antibody itself and known as, “antigen blocking”. When high doses of antibody interact with the entire antigen’s epitopes thereby inhibits interactions with B-cell receptors.

10.2.4 Cell mediated immunity

T cells are responsible for **cell-mediated immunity.** T cells are initially formed in the bone marrow and get its maturation and differentiation in the **thymus gland.** After maturation T cells migrate to **secondary lymphoid organ.** T cells are classified according to their functions and cell-surface marker called CD (clusters of differentiation). They are functionally classified as T helper, T suppressor, T memory and T killer cells. **T cells** are associated with certain types of allergic reactions called **Delayed hypersensitivity** and also in transplanted organ rejection.

The **Major Histocompatibility Complex (MHC)** are unique to each individual and indicate **self-molecules** and always these molecules are given as reference when ever an antigen is presented and this helps the immune system to differentiate the self from non-self. (fig. 3) **Helper T (T_H) cells** (also known as **CD4 cells**) activate B cells to produce antibodies against T-dependent antigens (usually protein in composition). T_H cells recognize and bind to an **antigen in association with an MHC II** (Fig. 3) on the surface of an **antigen presenting cells (APC)** and the APC cell **secrete** the **cytokine IL-1** and induce the T_H cell to secrete the

cytokine **IL-2**. Only T_H cells that have been **stimulated by an antigen** have receptors for IL-2 and thus these T_H cells are specific for only that stimulatory antigen. Production of IL-2 and other cytokines by these T_H cells stimulates the cell-mediated (e.g., T_C cells) and humoral (B cells-Plasma cell) immune responses. In Acquired Immuno Deficiency Syndrome (AIDS), the Human Immuno deficiency virus (HIV) affect the T helper cells. **Suppressor (T_S) cells** appear to regulate the immune response once the antibody formation reached the adequate levels. Cytotoxic T cells (CD8) identify the viral infected cells and inject the molecule called Perforin to lyse the viral infected cells. Some of the activated T cells become **T memory cells**.

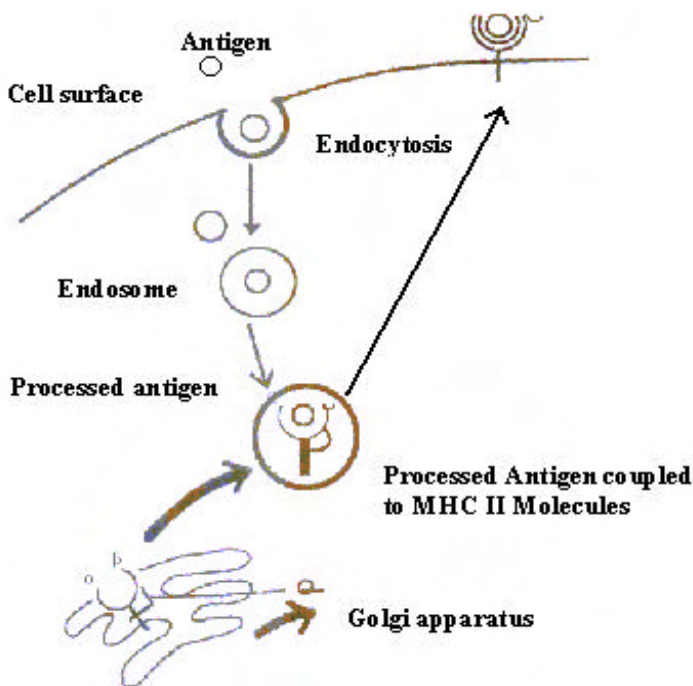

Fig.10.3 Major Histocompatibility Complex class II with processed antigen

10.2.4.1 Role of lymphokines

Lymphokines are the cytokines secreted by the lymphocytes and these are small molecules released due to a stimulus and help to send the signal between cells. The term interleukin (IL) is also often referring to the cytokine produced by leukocytes. There is considerable overlap between the actions of the individual lymphokines, so that many of the above effects are shared between $\text{TNF}\alpha$, IL-2 to IL-12. In addition, these pro-inflammatory cytokines activate the immune system, mobilizing neutrophils from bone marrow, causing dendritic cells to migrate to lymph nodes, and also initiating changes in adipocyte and muscle metabolism and also responsible for inducing fever.

10.3 Antigens

An **antigen** is a **foreign substance**, which is recognized by the immune system. Antigens can be defined as a substance that can combine specifically to the components of immune response such as lymphocytes and antibodies. An immunogen is any substance that has the ability to evoke B or T or both B and T mediated immune reactions. Whole antigen cannot combine with the antibody as antibodies are formed against specific regions on the surface of an antigen called **antigenic determinant or epitopes**.

10.3.1 Structure and Types of Antigens

An antigen molecule may contain a number of similar group or different antigenic determinant. The figure 10.4 shows that a cell which contains different groups of molecules over the surface. However only the group **a** and **d** has been selected for antigen processing. Hence **a** and **d** are antigenic determinant. Normally antigens are multi determinant

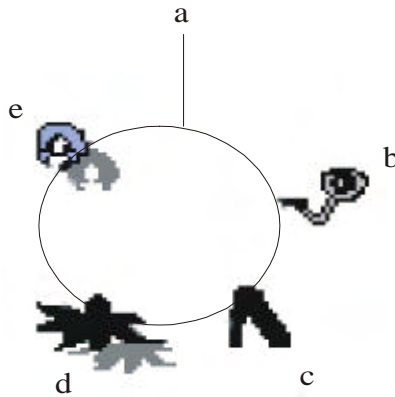

Fig 10.4 Antigen

Types of antigen

Antigen possesses several unique molecular structures which can induce an immune response. Most antigens are proteins, nucleoproteins, lipoproteins, glycoproteins, or large polysaccharides with a molecular weight greater than 10,000. To become an antigen the molecule must be relatively having a higher molecular weight. Large antigenic molecule posses many antigenic determinant per molecule. However the low-molecular-weight substance that can combine with an antibody but cannot induce the formation of antibodies are called as **haptens**. They can also initiate antibody response when they are combined covalently with a **carrier molecule**. Since antigens stimulate the immune response they are other wise called as immunogens.

10.3.2 Factors influencing the antigenicity of antigens

Antigen must be a **foreign** substance as more foreign the substance, the more immunogenic in nature. However the following factors can also influence it,

- 1) The antigenic response which is indicated by the quantum of antibody formed in response to antigenic stimulation varies depending on the

dosage of antigen administered, route of administration and use of **adjuvant** etc.

- 2) **Molecular weight** of the antigen affect the antigenicity as low molecular antigens can only combine with the antibody (haptens)
- 3) Very low molecular weight substance cannot act as an antigen. Because of this the virus which has the very low molecular weight proteins escapes the immune response.
- 4) Very large molecular antigen directly induces the B cell differentiation with out the involvement of T Cells.
- 5) **Degradability** is essential as in the antigen presenting cells process the antigen by degrading them and processed peptide antigen along with the MHC II molecule presented to the T cells and such antigens are called **T dependent antigen**.
- 6) Antigen induced antibody response can be suppressed by administrating the antibody passively either prior to or shortly after administration of antigen (This is utilized for the treatment of Rh antigen induced antibody in the mother leading to Erythroblastosis fetalis).

10.4 Antibodies

Antibodies found in the serum and other body fluids of vertebrates that react specifically with the Ag. Antibody belongs to a family of globular protein called Immunoglobulin. Antibody are Gamma globulins, in normal immune response antibodies are heterogeneous. It provides defense against extra cellular antigen.

Antibody has two main functions,

1. Bind specifically to foreign or non self molecules.
2. Recruit other cells and molecule to destroy the pathogen (effectors function or Biological activity)

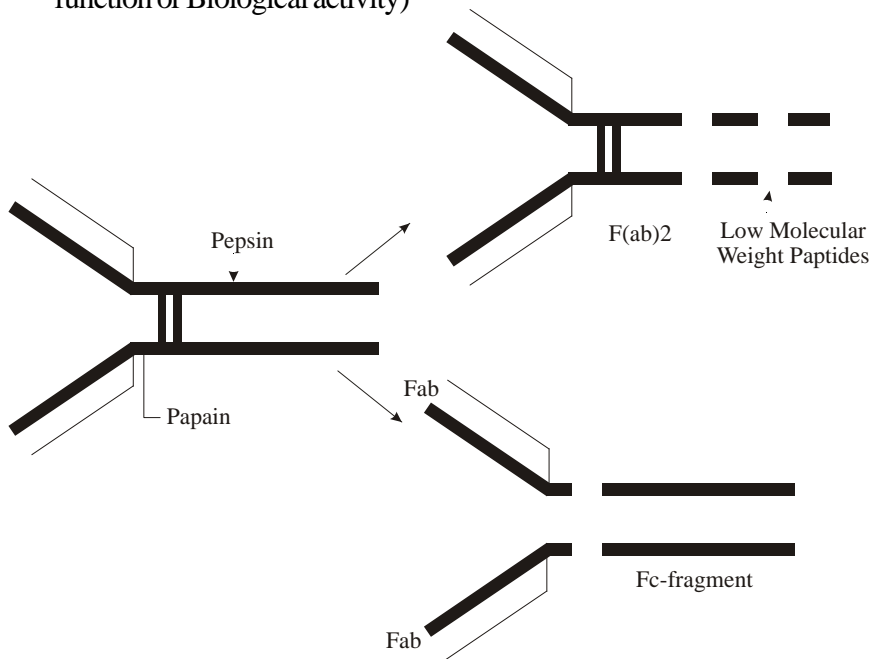

Fig.10.5 Papain and Pepsin cleavages

To understand the function of various ends in the antibody molecule the more abundant IgG molecule when subjected to papain and pepsin cleavages, as shown (Fig.10.5), the papain cleavage yields 2 monovalent Fab molecule which combine with the antigen (Fragment antigen binding) and one Fc part which can be the fragment crystallisable. When the same IgG molecule subjected to pepsin cleavage it resulted with a divalent antigen binding Fab part and fragments of Fc portion. This is because the papain cleaves between the heavy chain and the hinge region. The pepsin cleaves after the disulfide bridge. This enzymatic digestion also indicates

that the two disulfide bond hold the chains together. However the Fc portion is essential for biological activity. **Fc region** can attach to a host cell or complement or helps to cross the placenta.

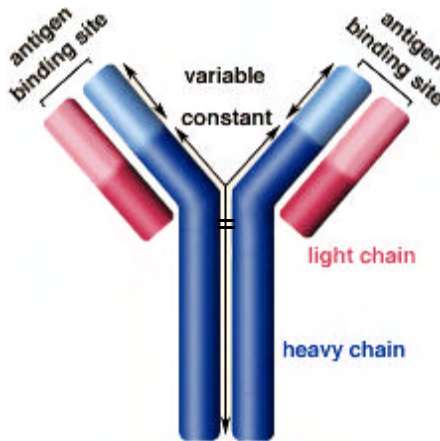

Fig. 10.6 Antibody Structure

10.4.1 Antibody Structure

A single antibody unit is 'Y' shaped molecule which is chemically a glycoprotein forms **the gamma globulin** in plasma (Fig. 10.6). Most antibody monomers consist of four polypeptide chains. Two are **heavy chains** and two are **light chains**. There is a **constant region**, which is ~~specific for a particular class of antibodies. For IgM the heavy chain is μ , for IgG it is γ , for IgA it is α , for IgD it is δ , and for IgE it is ϵ .~~ The light chain may either be κ (or) λ (kappa or lamda). The chains are folded into discrete regions called domains. There are 2 domain in the light chain and 4 to 5 domain in the heavy chains. In the constant region the free end forms the F_C portion. There is a variable region present in the heavy and

light chain and called as variable (**V**) **region**, where antigen binding occurs. Hence in a given antibody molecule two binding sites are available.

10.4.2 Types of immunoglobulins

An **antibody** or **immunoglobulin (Ig)** is glycoprotein produced by B cells, which is capable of combining specifically with the antigen, which induces it. Antibodies are divided into five major classes, IgM, IgG, IgA, IgD and IgE, based on their heavy chain constant region structure. An antibody has at least two identical **antigen-binding sites and it is the valence of** an antibody.

10.4.3 Immunoglobulin and their functions

IgG has two light chains either kappa or lambda and two heavy chain of γ type and consists of four subclasses IgG1, IgG2, IgG3 and IgG4. It is predominant class of immunoglobulin and account for approximately 80% in human serum. IgG produced particularly during the secondary immune response. IgG stimulates phagocytic cells, activates the complement system, binds neutrophils, and can neutralize toxins. Most importantly, it is the only antibody that can cross the placenta and confer immunity on the foetus..

IgA has two light chains either kappa or lambda and two heavy chain of α type and consist of two subclasses IgA1 and IgA2, constitutes only 13% of the antibody in human serum, but predominant class of antibody in extravascular secretions. The IgA present in secretions (tears, saliva, nasal secretions and mammary gland secretions) is secretory IgA. It is found to produce immunity against tapeworms and present in the colostrums protects the baby from intestinal pathogens.

IgM has two light chains either kappa or lambda and two heavy chain of μ type constitutes 8% of the antibody in human serum, it is the largest of the immunoglobulins often referred as the macroglobulin because it has more than five binding sites for antigen. It is the first antibody to appear in the primary immune response therefore an useful indicator of recent infection. Most of the natural antibodies like ABO blood grouping (anti-A anti-B) are of the IgM class and important in the initial activation of B-cells, macrophages, and activate the complement system.

IgD has two light chains either kappa or lambda and two heavy chain of δ type constitute less than 1% of the antibody in human serum. Plays a role in activating and suppressing lymphocyte activity and found large quantities in the cell walls of many B-cells. IgD has a single binding site.

IgE is a reaginic antibody, has two light chains either kappa or lambda and two heavy chain of ϵ type constitute less than 0.003% of the antibody in human serum. Mediator in allergic responses. Most importantly activates histamine secreting cells. Also appears to play a role in parasitic infection and mediates type one hypersensitivity.

10.5 Antigen antibody reactions

The interaction of an antigen determinant and antibody molecule is called immune complex or antigen - antibody complex. Various factors influencing antigen-antibody complex. Specificity antibody to combine with only one type of antigen, Binding site of antigen and antibody (epitope and paratope), Binding forces of antigen and antibody – closeness between antigen and antibody and intermolecular forces, Affinity (attraction of

Ag- Ab binding) and Avidity (combining capacity of heterogenous antibodies with multivalent antigen).

The first interaction of an antigenic determinant (epitope) with its corresponding antigen binding site on an antibody is called a primary antigen- antibody reaction. The primary antigen-antibody reactions are rapid reaction, not dependent on electrolytes and not visible. If the primary antigen- antibody reaction is followed by the aggregation of antigen antibody complexes into macroscopically visible clumps is called the secondary antigen-antibody reaction and this aggregation phase may take hours to day to reach maximum. The two visible reactions are called precipitation and agglutination.

10.5.1 Precipitation

Precipitation is the combination of soluble antigen with specific antibody, which leads to the formation of an insoluble aggregation. Immune precipitation occurs when antigen and antibody combine in solution and form a visible aggregate. Precipitation reaction is quantifiable. The variation in the ratio of antibody- antigen leads to different levels of lattice formation, and thereby to different amounts of precipitate. This phenomenon, called the prozone phenomenon where antibody may excess, zone of equivalence of antigen- antibody or antigen may excess. Factors affect precipitation are temperature, pH, salt concentration and reaction volume.

10.5.2 Agglutination

The clumping, or agglutination, of particulate antigens by specific antibodies. Clumping results in the formation of a lattice in which antigen and antibody are cross linked. Agglutination methods are qualitative or

semi quantitative at best and its reaction can be used in many applications as it poses a high degree of sensitivity. Agglutination reactions can be classified as either direct or indirect. In the direct agglutination reaction, the antigenic determinant is a normal constituent of the particle surface. In the indirect agglutination a molecule is ordinarily soluble is attached to a particle and rendered insoluble.

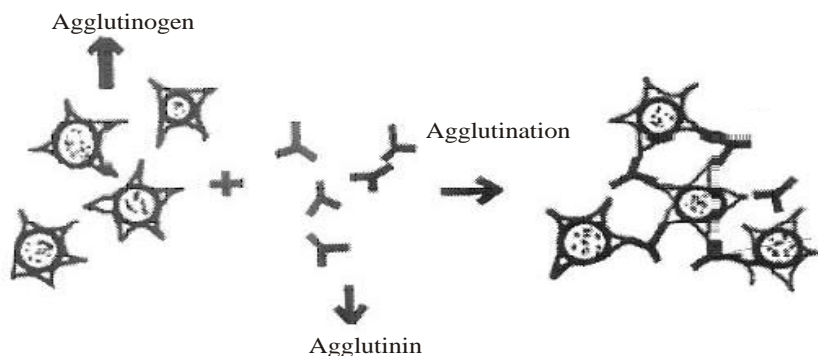

Fig.10.7 Process of agglutination

10.6 Blood groups

In 1901 Karl Landsteiner discovered that when the Blood of one human being was transfused with that of another human being, differences in their Blood leads to shock, jaundice, and renal failure. Since the blood group antigen and antibody reactions result in the agglutination reaction the **antigen is known as agglutinogen** and the **antibody is known as agglutinin**. Blood group antigens are present on the RBC membrane. According to Land Steiner when an agglutinogen is present on the RBC membrane the corresponding antibody is absent in the plasma. So your 'blood group' depends on type antigens which found on the surface of the red blood cell membrane.

10.6.1 ABO System

Land Steiner found two types of antigens on the RBC they are antigen A and antigen B, similarly there are two types of antibodies in the

plasma called antibody alpha and beta antibody. Since this antigen antibody involved in agglutination reactions the antigen is called as agglutinin and the antibody is known as agglutinin. According to Land Steiner's law when an agglutinin is present on the RBC the corresponding antibody will be absent in the plasma. Based on the presence or absence of antigens and antibodies human blood is classified into four major groups namely A, B, AB and O.

Blood group A

If you belong to the blood group A, you have A antigens on the surface of your red blood cells and beta antibodies in your blood plasma.

Blood group B

If you belong to the blood group B, you have B antigens on the surface of your red blood cells and alpha antibodies in your blood plasma.

Blood group AB

If you belong to the blood group AB, you have both A and B antigens on the surface of your red blood cells and both alpha and beta antibodies are absent in your blood plasma.

Blood group O

If you belong to the blood group O (null), you do not have the A and B antigens on the surface of your red blood cells but you have both alpha and beta antibodies in your blood plasma.

Rhesus types

It is also like the blood group antigen and also present in the cell membrane. Since this antigen was found in Rhesus monkey first they called this antigen as Rhesus antigen or Rh system. Most people are 'rhesus positive' as they have rhesus antigens on their red blood cells. But, about 3 in 20 people do not have rhesus antigen and are said to be 'rhesus negative'.

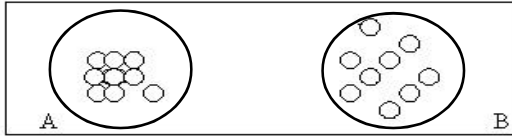

Antibody to A antigen shows agglutination-A group

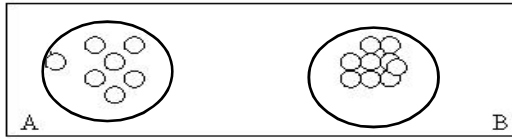

Antibody to B- antigen shows agglutination -B group



Antibody to A and B- antigen shows agglutination -AB group

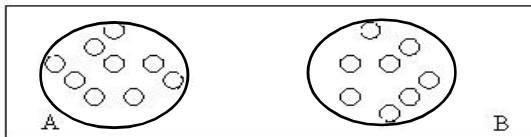

Antibody to A and B antigen shows no agglutination -O group

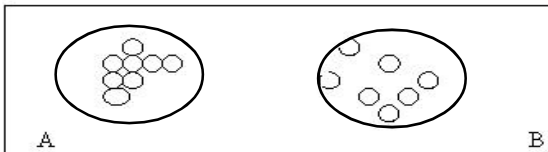

**Antibody to Rh antigen shows agglutination in A -Rh positive
Antibody to Rh antigen shows no agglutination in B Rh negative**

Fig.10.8

How blood group testing is done?

Basically, a sample of blood is mixed separately with anti-A antibodies, anti B antibody and Rh antibodies. If the red cells to clump together with anti-A antibodies, then it indicate the presence of A antigens in the blood cells and the person belongs to A group. Similarly if agglutination reaction occurs with anti B antibodies then it indicates the presence of B antigen. When agglutination is found in both anti A and anti B antibodies it indicates that the person belongs to AB group. If no agglutination found with both antibodies of A and B then it indicates the absence of antigens and the person belongs to O group.

Similarly if an anti Rh antibody shows agglutination with the given blood then it indicates the presence of Rh antigens on the blood cells. Hence the person is Rh positive. If no agglutination seen then the person is Rh negative.

Blood groups and pregnancy

The blood group test is a must for pregnant women. If the mother is Rh negative, and the fetus is Rh positive (inherited from a Rh positive father), when the fetal blood enters in to mothers body due to some reason the mother become sensitized. The mother's immune system produce antibody against the Rh antigen. When these antibodies enter in to fetus, these may attack and destroy the baby's blood cells. When there is a reduction in the functional RBC, the immature blast cells come to the fetal circulation. This condition is called 'Erythro blastosis fetalis (Because erythroid (red blood cells) blast cells are found in the fetus). However, without treatment, this can become a serious problem in subsequent pregnancies as the mother's immune system will be 'sensitized' after the

first pregnancy. The baby with this disorder will have anemia, jaundice and in many cases the mental retardation.

10.6.1.1 Antigens and natural antibodies of ABO blood groups:

Isoantibodies : (Iso means belonging to the same species) Isoantibody is an antibody produced by one individual that reacts with the antigen of another individual of the same species. Antibody – A and Antibody – B are called Isoantibodies.

Isoantigens : An antigen of an individual which is capable of eliciting an immune response in individuals of the same species who are genetically different and who do not possess that antigen is called isoantigen.

Natural antibodies : Human forms antibodies against the blood group antigens they do not express. These antibodies are called naturally occurring antibodies or isoagglutinins. It may be of IgM, IgG or IgA. Antibody production starts at 3 months of age, reaches its highest level during adult and decreases with advancing age. Usually, Antibody A titers are higher than Antibody- B.

Excercises

I. Choose the correct answer from the given four alternatives

- a. What is the function of B and T memory cells?
 - i) Phagocytosis
 - ii) Secondary immune response
 - iii) Primary immune response
 - iv) Production of Antibody is inhibited

- b. Immunoglobulin which can cross the placenta
 - i) IgA
 - ii) IgE
 - iii) IgM
 - iv) IgG

- c. Type of heavy polypeptide chain present in the IgM molecule
- | | |
|-------------|--------------|
| i) δ | ii) κ |
| iii) μ | iv) α |
- d. In AIDS, the cells which are affected by HIV
- | | |
|-------------------------|--------------------|
| i) Mast cells | ii) T helper cells |
| iii) T suppressor cells | iv) B memory cells |
- e. Haptens
- Low molecular weight substances which can not induce formation antibodies
 - High molecular weight substances which can not induce formation antibodies
 - Carrier molecule which can induce immune response
 - Can activate B cells directly

II . Fill up the blanks :

- Infection acquired during hospital stay is called as _____
- Recognition and destruction of cancerous cells is done by _____
- Substances which are released by Cytotoxic T cells over the cells carrying the viral particles, are called as _____
- Opsonization of bacteria is done by _____ part of the complement .
- Function of Fab part of antibody molecule is _____
- Erythroblastosis fetalis is caused by _____ antigen.

III. Say True or False

- Cells of natural immunity and acquired immunity are not interacting with each other.

2. Lymphokines are mediators released by T killer cell to kill the tumor cells.
3. Opsonins prevent phagocytosis.
4. Adaptive immunity functions are non specific.
5. Interferons are responsible for the fever during infection.

IV. Match the following

- | | | |
|----------------------|----|---------------------------------------|
| 1. Adhesion molecule | —— | Expressed by antigen presenting cells |
| 2. Chemotaxis | —— | Attraction of phagocytes |
| 3. MHC II | —— | Indicates inflammation |
| 4. Kupffer cells | —— | Helps for Margination |
| 5. Pharyngitis | —— | Reticulo endothelial system |

V. Give short answer for the following

1. What is MHC ? What is its role in our body ?
2. Name the antigen presenting cells and their role ?
3. What is Land Steiner's law ?
4. What is cell mediated immunity ? Name the components of cell mediated immunity ?
5. Name the factors affecting the antigenicity of an antigen?